

OWNER'S INSTRUCTION MANUAL

**BELL & HOWELL**

**FILMOSOUND<sup>®</sup> 16mm PROJECTORS**

**3580 3575**

***Slot-Threading Series***

# BELL & HOWELL

## Slot-Threading Series

MODEL	OPTICAL SOUND	MAG SOUND	FRONT COVER SPK.	LAMP TYPE	HI-LO LAMP SWITCH	FUNCTION CONTROL	AMP POWER	WEIGHT LBS	WEIGHT KG	SIZE INCHES	SIZE MM
3580	●			ELC/EAL 250W/24V	●	ROTARY SWITCH	28W	29.1	13.2	14.4 X 11.8 X 8.1	365 X 300 X 206
3580-1	●		●	"	●	"	"	32.2	14.8	14.4 X 11.8 X 9.3	365 X 300 X 236
3580-2	●	●	●	"	●	"	"	"	"	"	"
3575	●			BYK/WWG 300W/120V		"	15W	24.5	11.1	14.4 X 11.8 X 8.1	365 X 300 X 206

**Simple Operation**  
**Easy Maintenance**  
**Trouble-Free Use**

This Operator's Manual is easy to read, informative and helpful.

Please read it carefully. Before you try it your way, please try it our way.

### CONTENTS

Specifications . . . . .	1
Main Parts of the Projector . . . . .	2
Setting up the Projector . . . . .	3
Threading Instructions . . . . .	7
Projecting . . . . .	8
Rewinding . . . . .	10
Removing the Lens . . . . .	12
Changing Lamps . . . . .	13
Hi-low Lamp Switch . . . . .	16
Still Frame or Pause . . . . .	17
Spare Parts and Accessories . . . . .	18
Special Applications . . . . .	20
(a) Using Projector as a P.A. System . . . . .	20
(b) Magnetic Sound Track Operation (TYPE 2 ONLY) . . . . .	21
(c) 50HZ to 60HZ Conversion . . . . .	22
(d) Special Dual Voltage Applications . . . . .	23
(e) Silent Film Operation . . . . .	24
Cleaning and Maintenance . . . . .	25
Operator Trouble Shooting Guide . . . . .	26

---

# IMPORTANT SAFEGUARDS

When using your **BELL&HOWELL** 16mm projector, basic safety precautions should always be followed, including the following:

1. Read and understand all instructions.
2. Close supervision is necessary when any equipment is used by or near children. Do not leave projector unattended while in use.
3. Care must be taken as burns can occur when changing lamp. Use lamp ejection lever provided to avoid possibility of burns from a hot lamp.
4. Do not operate projector with a damaged cord or if projector has been dropped or damaged — until it has been examined by a qualified service technician.
5. Do not let the cord hang over edge of the table or counter or touch hot surfaces.
6. If an extension cord is necessary, a cord with a suitable current rating should be used. Cords rated for less amperage than the projector may overheat. Care should be taken to arrange the cord so that it will not be tripped over or pulled.
7. Always unplug projector from electrical outlet when not in use. Never yank cord to pull plug from outlet. Grasp plug and pull to disconnect.
8. Let projector cool completely before putting away. Return cord to cord storage space provided when storing projector.
9. To protect against electrical shock hazards, do not operate this projector in the rain or when wet.

— to be continued —

---

## **IMPORTANT SAFEGUARDS (cont'd)**

10. To avoid electric shock hazard, do not disassemble this projector, but refer to a qualified service technician when service or repair work is required. Improper repairs or reassembly can cause electric shock hazard when the projector is used subsequently.
11. Do not remove lamphouse cover when projector motor is running.
12. Observe the caution plate on rear cover "DISCONNECT POWER SUPPLY BEFORE OPENING".
13. Do not look directly at an operating lamp with unprotected eyes.
14. Observe the caution plate inside of lamphouseing.  
"DISCONNECT POWER BEFORE REPLACING LAMPS".

## **SAVE THESE INSTRUCTIONS**

"The Eiki Company has purchased the AV/Video Div. of the Bell & Howell Company and has exclusive rights to manufacture and distribute the products of this division in the U.S.A."

# SPECIFICATIONS

<b>Power Requirement:</b>	Models available from 100 to 240VAC 50 or 60Hz
<b>Power Consumption:</b>	430 to 470 watts
<b>Lamp:</b>	3580 models use ELC, 250 watt 24 volt lamps 3575 models use EYK or EWG, 300 watt 120 volt lamps
<b>Hi-Low Lamp Switch:</b>	All models except 3575
<b>Exciter Lamp:</b>	4 volt 0.75 amp type BRK
<b>Lens:</b>	50mm (2") F, 1.2 6 element 160 lines center resolution standard
<b>Film Speed:</b>	24 frames/second standard sound speed
<b>Shutter:</b>	3 blade (2 blade optional)
<b>Reel Capacity:</b>	2000' (600m)
<b>Function Controls:</b>	Rotary switch
<b>Still Picture:</b>	All models except 3575
<b>Amplifier:</b>	All solid state
<b>Power Output:</b>	25 watts RMS, 8 ohm load for models 3580 15 watts RMS, 8 ohm load for model 3575
<b>Tone Controls:</b>	Bass and Treble
<b>Frequency Response:</b>	50 — 7000Hz
<b>Aux Line Out:</b>	600 ohm un-balanced, all models except 3575
<b>Microphone Input:</b>	Low impedance, un-balanced
<b>Speakers:</b>	10 x 15cm (4 x 6") built in rear cover speaker. 2 pcs., 12.5cm (5") speaker in front cover on optional models
<b>Wow &amp; Flutter:</b>	Better than 0.2% weighted
<b>Elevation:</b>	13° maximum
<b>Operating Temperature and Humidity:</b>	+5° C to +40° C 20% to 90%
<b>Weight:</b>	11 to 15kg (25 to 33 lbs)

# MAIN PARTS OF THE PROJECTOR

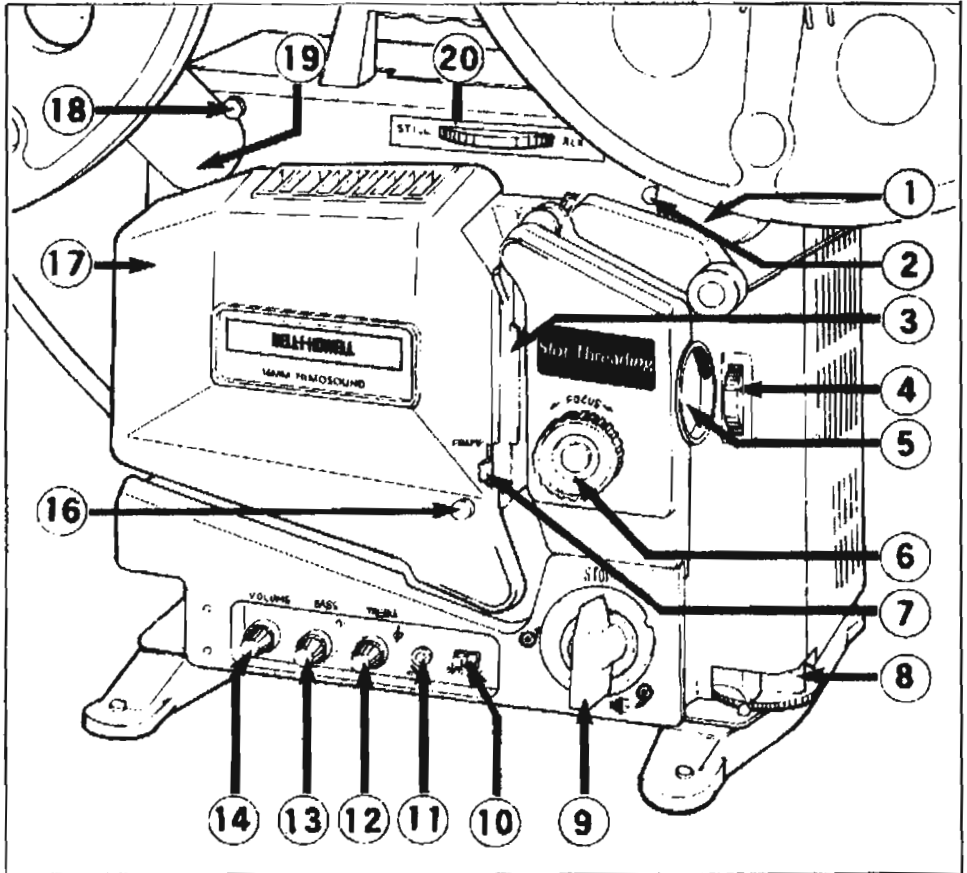

- |   |   |
|---|---|
| 1. Supply arm   | 12. Treble control                        |
| 2. Supply arm lock button                                   | 13. Bass control                          |
| 3. Film gate  | 14. Amplifier ON & OFF and volume control |
| 4. Inching knob   | 16. Lamp house cover screw                |
| 5. Lens   | 17. Lamp house cover                      |
| 6. Focus knob   | 18. Take-up arm lock button               |
| 7. Framing lever  | 19. Take-up arm                           |
| 8. Elevator knob  | 20. Still picture clutch (3580 only)      |
| 9. Function switch  |   |
| 10. Optical/Magnetic playback selector switch (TYPE 2 ONLY) |   |
| 11. P.A. microphone jack                                    |   |

# SETTING UP THE PROJECTOR

1. Lift latch to remove front cover.

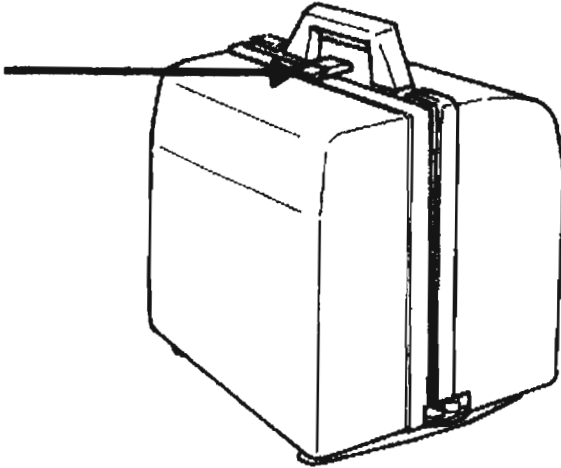

2. Raise both reel arms until they snap in place.

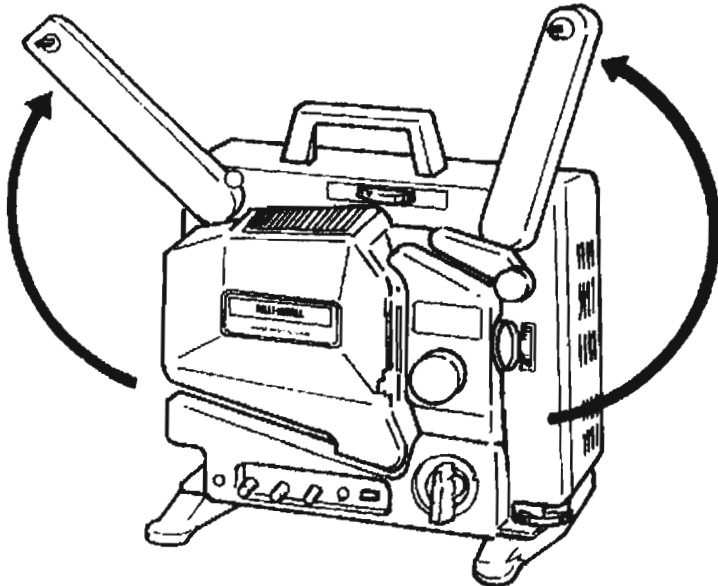

3. Set function switch to STOP position.



4. Connect power plug to proper outlet.

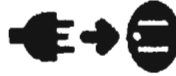

5. Switch projector to forward and lamp on.

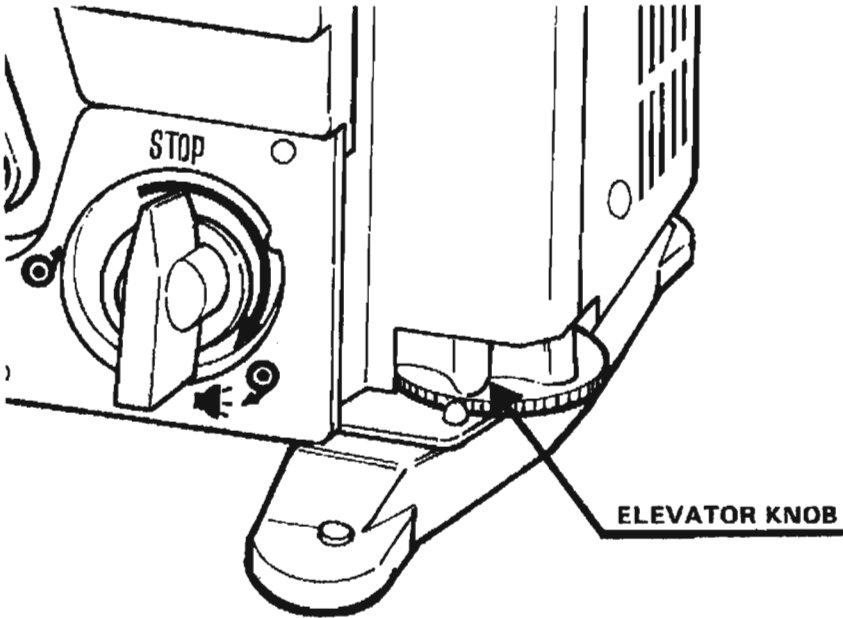



6. Position projector for the appropriate size image as desired. Adjust elevator knob to achieve the required image height. (See chart below for appropriate lens, distance and screen size.)

### SCREEN SIZE CHARTS IN METERS

Distance Lens			3m	5	10	15	20	25	30	40
	38mm	H	W	0.56 0.76	0.84 1.26	1.89 2.53	2.84 2.80	3.79 5.07	4.74 6.34	5.69 7.61
50	H	W	0.43 0.57	0.72 0.96	1.44 1.93	2.16 2.89	2.88 3.86	3.60 4.82	4.32 5.76	5.76 7.72
	65	H	W	0.33 0.44	0.55 0.74	1.10 1.48	1.66 2.27	2.21 2.96	2.77 3.71	3.32 4.45
76	H	W	0.28 0.38	0.47 0.63	0.94 1.26	1.42 1.90	1.89 2.53	2.37 3.17	2.84 3.80	3.79 5.07
	100	H	W	0.21 0.28	0.36 0.48	0.72 0.96	1.08 1.44	1.44 1.93	1.80 2.41	2.16 2.89

### SCREEN SIZE CHARTS IN INCHES

Distance Lens			8'	10'	12'	15'	20'	25'	30'	36'	40'	45'	50'	60'	75'	100'
	1'	H	W	2.2' 2.11'	2.9' 3.8'	3.4' 4.5'	4.2' 5.7'	5.7' 7.5'	6.11' 9.4'	8.4' 11.3'	9.9' 13.1'					
1.5'		H	W	1.5' 1.11'	1.10' 2.5'	2.2' 2.11'	2.9' 3.8'	3.8' 4.11'	4.7' 5.2'	5.7' 7.6'	6.8' 8.9'	7.5' 10.0'	8.4' 11.3'	9.4' 12.5'		
	2.0'	H	W		1.4' 1.10'	1.8' 2.2'	2.1' 2.9'	2.9' 3.8'	3.6' 4.8'	4.2' 5.7'	4.10' 6.6'	5.7' 7.5'	6.3' 8.5'	6.11' 9.4'	8.4' 11.3'	10.8' 14.0'
3.0'		H	W						2.3' 3.1'	2.9' 3.8'	3.3' 4.4'	3.8' 4.11'	4.2' 5.7'	4.7' 6.2'	5.7' 7.5'	6.11' 9.4'
	4.0'	H	W						1.8' 2.3'	2.1' 2.9'	2.5' 3.3'	2.9' 3.8'	3.1' 4.2'	3.5' 4.8'	4.2' 5.7'	5.2' 7.0'

7. Adjust focus for clean, sharply illuminated screen.

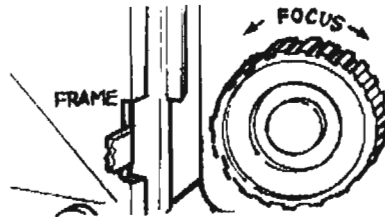

8. When desired projection position and screen image size has been achieved, stop projector.

9. For larger groups the extension speakers located in the front cover (1, 2 types only) may be placed near the screen and plugged into the jack marked "speaker" located on the left of the projector. The internal speaker in the rear cover is then automatically disabled.

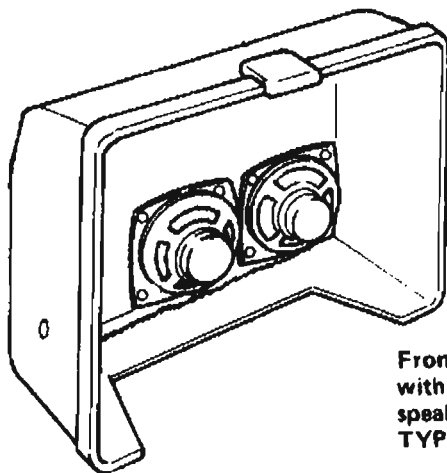

Front Cover  
with extension  
speakers  
TYPES 1, 2

10. For additional sound reinforcement the projector may also be connected to an external amplifier via the low level auxilliary line output. The 600 ohm (unbalanced) line is available at the speaker jack when using a 3 conductor (stereo type) ¼" phone plug wired as shown.

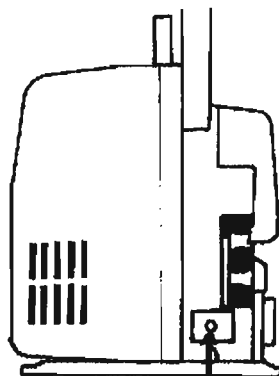

Speaker/aux jack

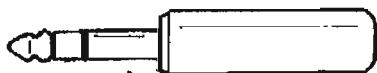

SLEEVE (SHIELD)

RING (COMMON)

TIP (HOT)

600 ohm aux output

8 ohm speaker

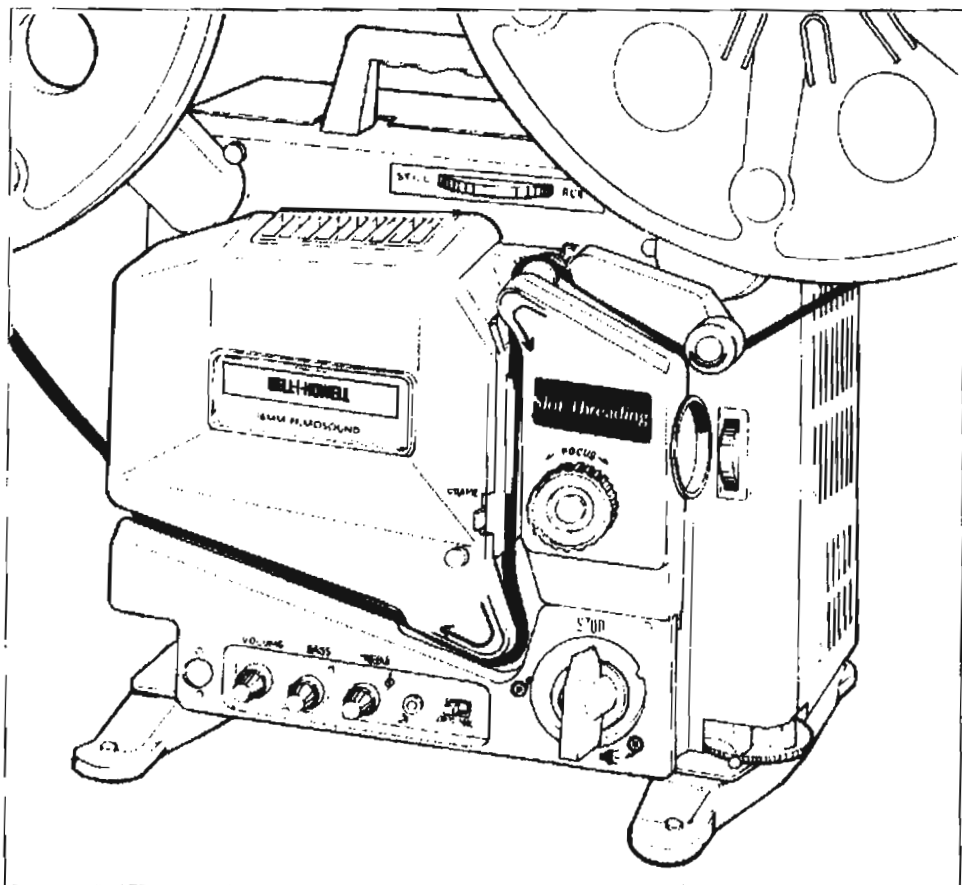

# THREADING INSTRUCTIONS



1. Switch function control to Stop position.
2. Hold the film by the fingertips, beginning at the first guide roller, pull the film along the slot following the direction of the arrows.
3. Attach the end of the film to the take-up reel and wind a couple of turns in the clockwise direction.

# PROJECTING

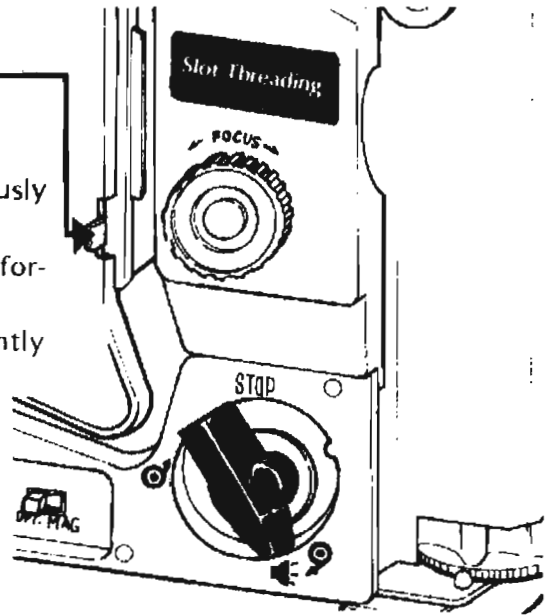

## FRAMING CONTROL LEVER

1. Thread projector as previously described.
2. Switch function control to forward  and then to lamp .
3. If a frame bar is visible slightly adjust the framing lever.

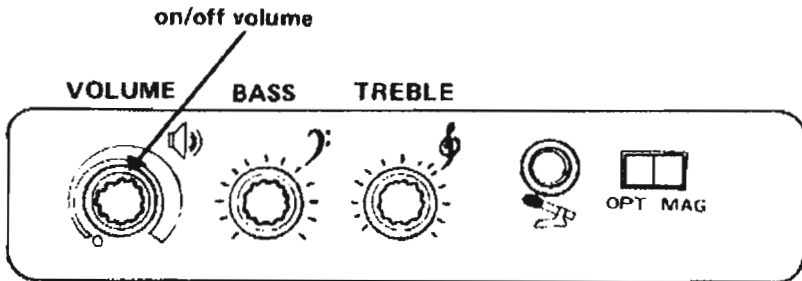

4. Adjust focus for sharp, crisp picture.
5. Wait 2 – 3 seconds for the first scene to appear, then turn on the amplifier.
6. Adjust the volume and tone controls to the desired level and most pleasing sound.



7. This projector features automatic "film guard." In the event the upper film loop is completely lost as a result of a previously damaged film the projector will stop automatically. Return the function switch to stop. Resetting the loops, then restart the show by advancing the function control to forward  and lamp .

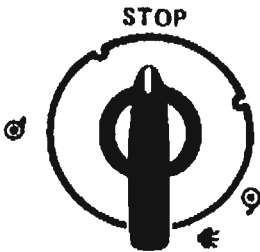

8. Loss of lower loop will cause the loop restorer to reset automatically without interruption of the show.

# REWINDING

Film may be rewound through the slot path, or direct from take-up to supply reel.

1. For in-path rewind, stop the projector before the end of the film trailer.

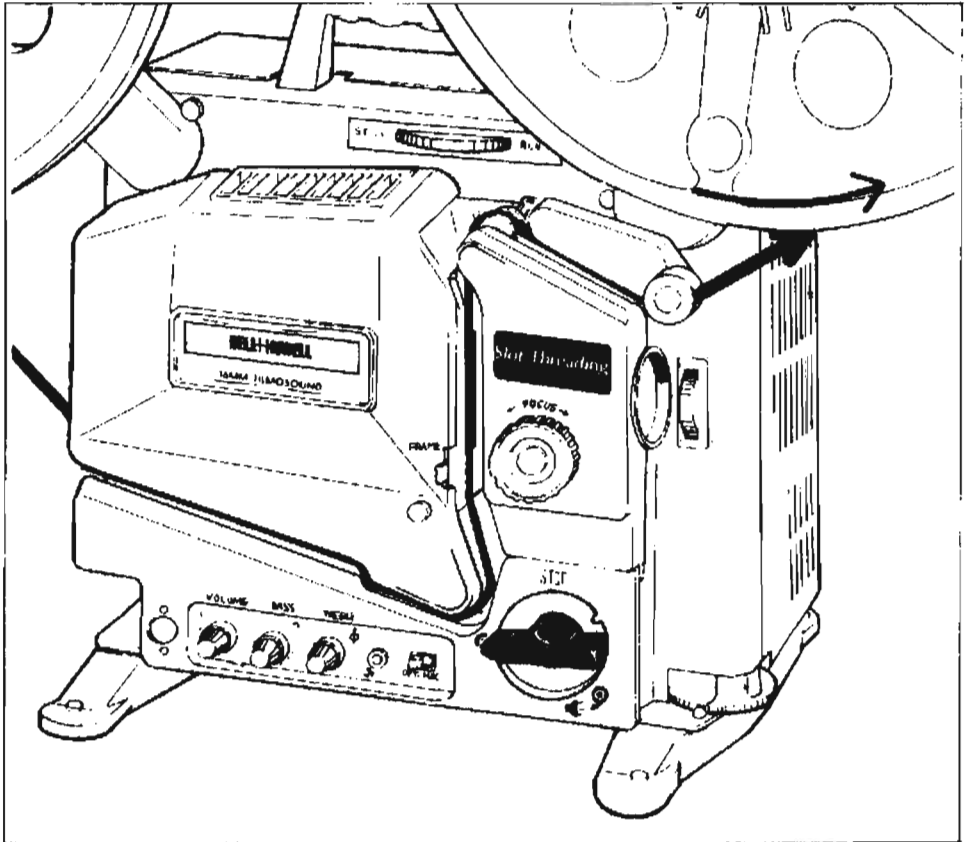

Rotate the function switch to rewind position.

Caution: Do not switch directly from forward to rewind without first stopping the projector at the STOP position.

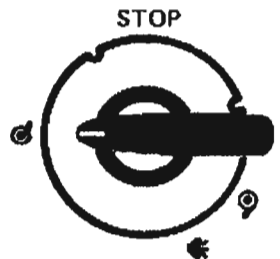

2. Reel-to-reel rewind. Bring the film directly from the take-up reel and attach it to the supply reel in a counter clockwise direction.

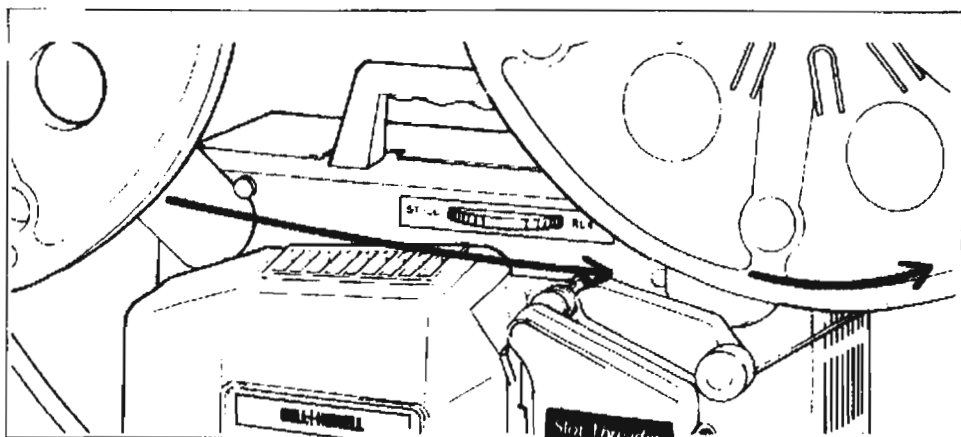

Rotate the function switch counter clockwise to the rewind position.

3. Return the function switch to "STOP" upon completion of the rewind

# REMOVING THE LENS

1. Remove lens holder mechanism cover by pulling out from the top as shown.

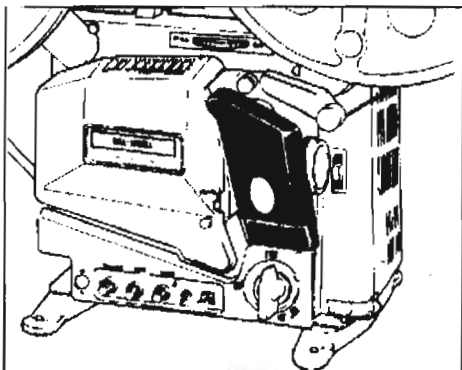

2. Unscrew the anti-theft screw on the lens holder.

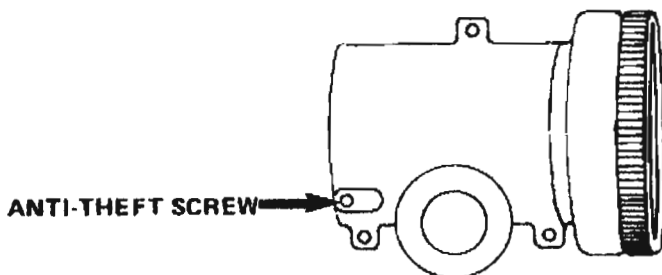

3. The lens can now be removed by turning the focus knob until lens is free.
4. To reinstall the lens, reverse the above procedure. Telephoto and wide-angle lenses can be installed in the same manner.



# CHANGING LAMPS

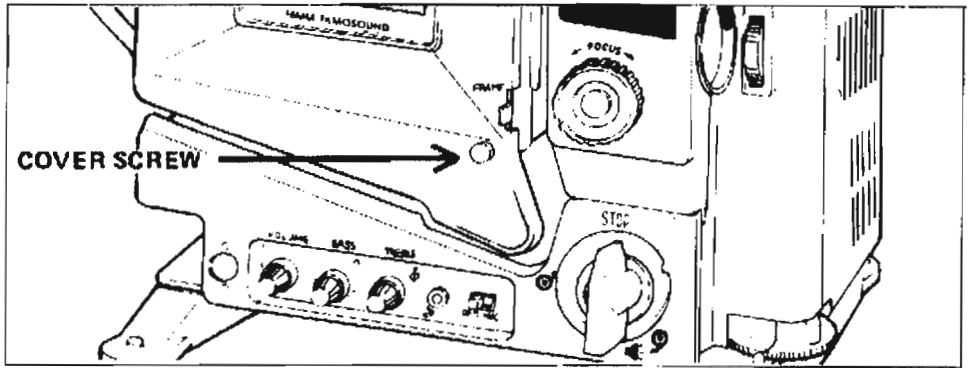

1. Loosen lamp house cover screw.
2. Lift from the bottom to remove lamp house cover.
3. To remove projection lamp: (ELC/EJL) 24V 250W or (EYK/EWG) 120V 300W. Note Label plate for correct replacement lamp.
  - a. Remove black heat shield by unscrewing the black thumb screw and pulling straight out.  
(CAUTION: heat shield may be hot)

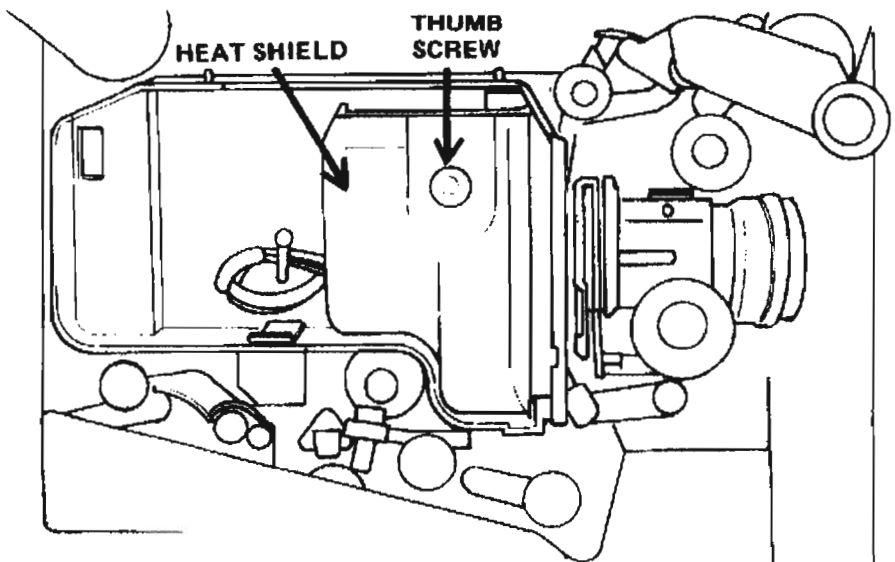

b. Push lamp ejection lever to the left and lamp will come out.

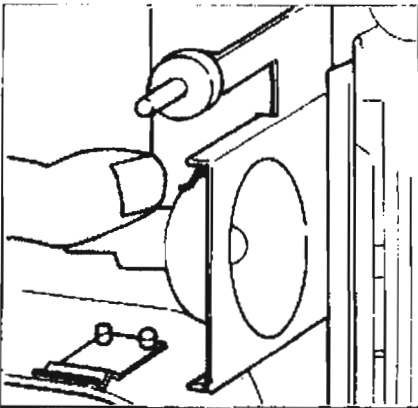

LAMP POSITION  
ADJUSTMENT

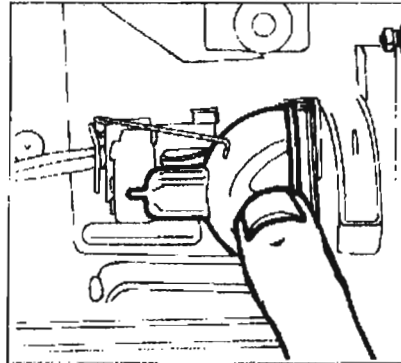

c. When replacing lamp be sure that it snaps into the socket properly and that the heat shield and cover is re-installed.

d. For maximum, even illumination it may be necessary to adjust the lamp position to allow for slight variations in lamps.

#### 4. Exciter lamp. (BRK/4V 0.75A)

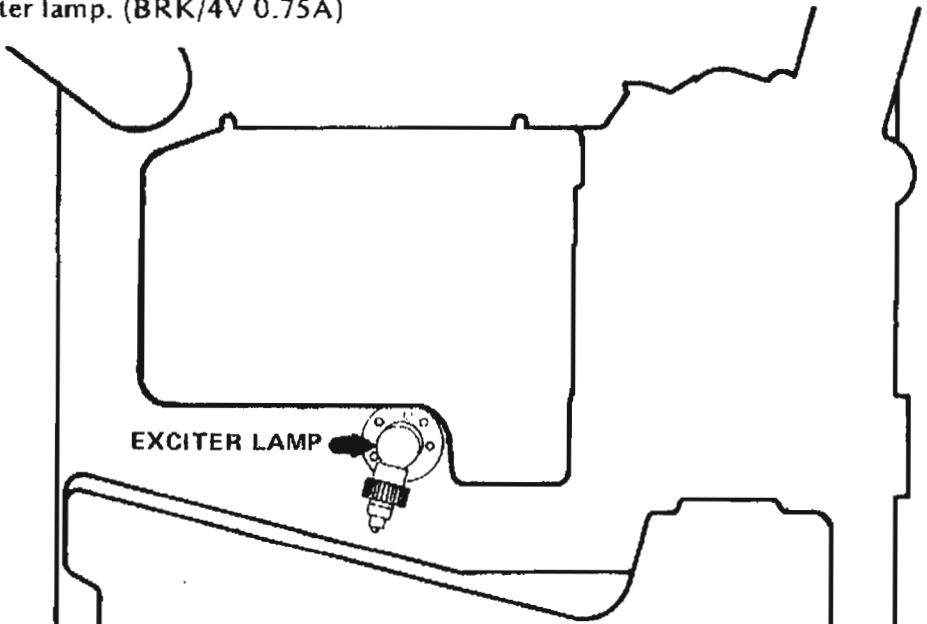

a. Push in on the lamp and turn counter clockwise to remove.

- 
- b. Insert new lamp with notch on base flange in upper right position. Turn clockwise, and clean fingerprints from lamp.

5. To re-install lamp house cover be sure the two pins on top of the lamp house line up with the holes in the cover. Snap closed and tighten the lamp house cover screw.

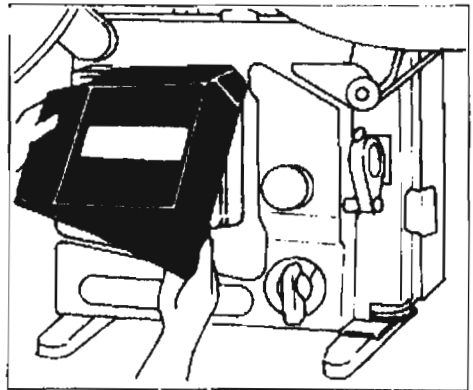

---

## HI-LOW LAMP SWITCH

Models with ELC or EJL 24V lamp are supplied with HI-LOW lamp selection (NOT AVAILABLE ON MODEL 3575)

The hi-low lamp switch is located inside the lamp house. To change the hi-low switch it is necessary to remove the lamp house cover as outlined for changing the lamp.

By switching to the low position the lamp will last nearly three times as long as in the hi position.

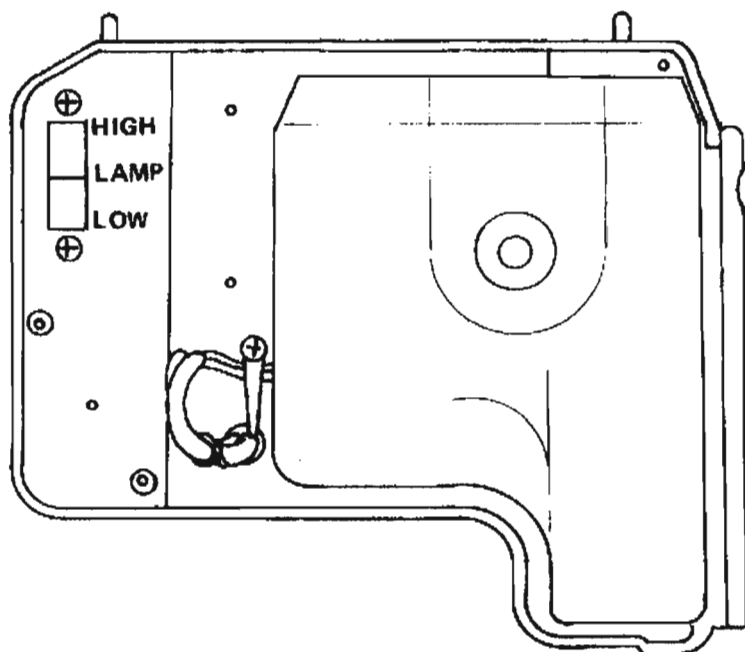

## STILL FRAME OR PAUSE

(Not available on Model 3575)

Models with still-run feature allows the film to be momentarily stopped for discussion at any time while in the forward project mode by switching the still/run control to still.

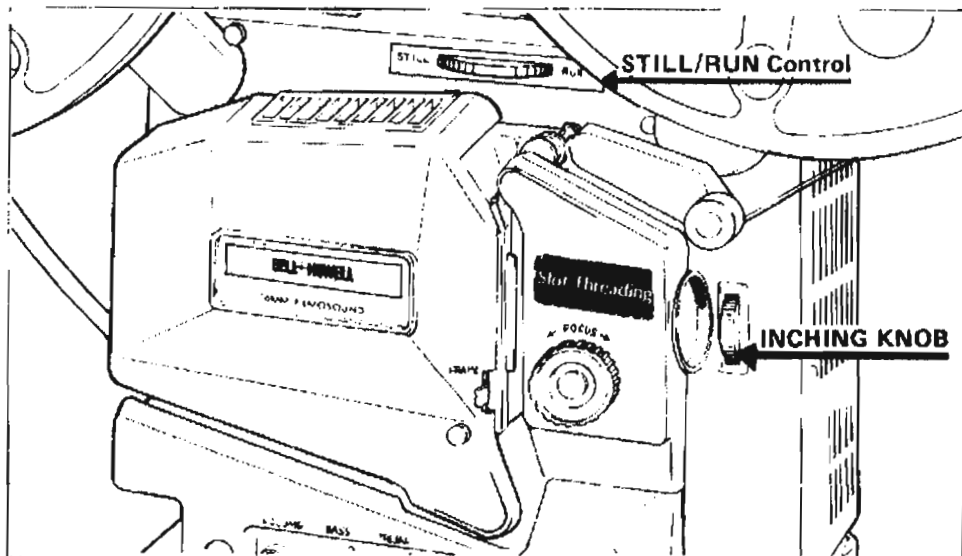

In the still or pause mode a heat screen is positioned in front of the lamp reducing the image brightness while protecting the film from excessive lamp heat. Should the shutter stop in front of the image, simply rotate the inching knob until the shutter is out of the picture.

# RECOMMENDED SPARE PARTS AND ACCESSORIES

## MODELS 3580

Projection Lamps — ELC/24V 250W (P/N 5100) →

If replacement ELC lamp is not available, a 24V-200W EJL lamp may be used. The EJL gives about 20% less light. (P/N 5102)

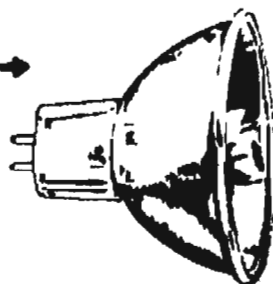

MODELS 3575 USE EYK/120V 300W (P/N 5115) or EWG/120V 300W (P/N 5103)

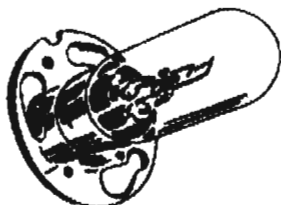

← Exciter Lamps BRK/4V 0.75 amp (P/N 5104)



↑  
Fuse 2 amp, Exciter lamp and amplifier (P/N F02-5020)



↑  
Fuse 5 amp Main Power (P/N F05-6030)

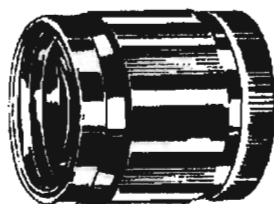

↑  
Zoom lens attachment (P/N 5024)  
(Continuously variable from 38mm (1-1/2") to 65mm (2-1/2") with standard prime lens)

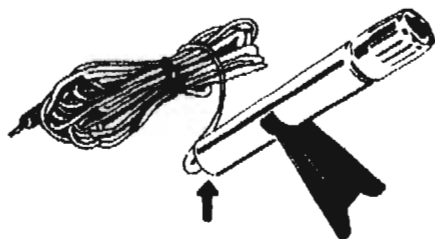

↑  
Microphone (P/N 5460)



Anamorphic/Cinemascope lens (P/N 5030), Requires Bracket

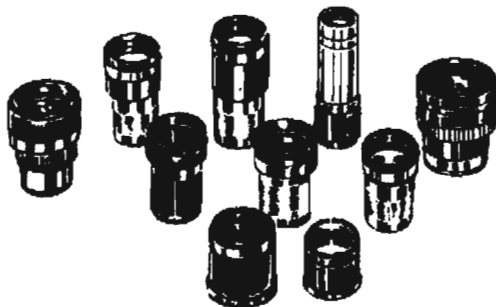

↑  
Additional lenses

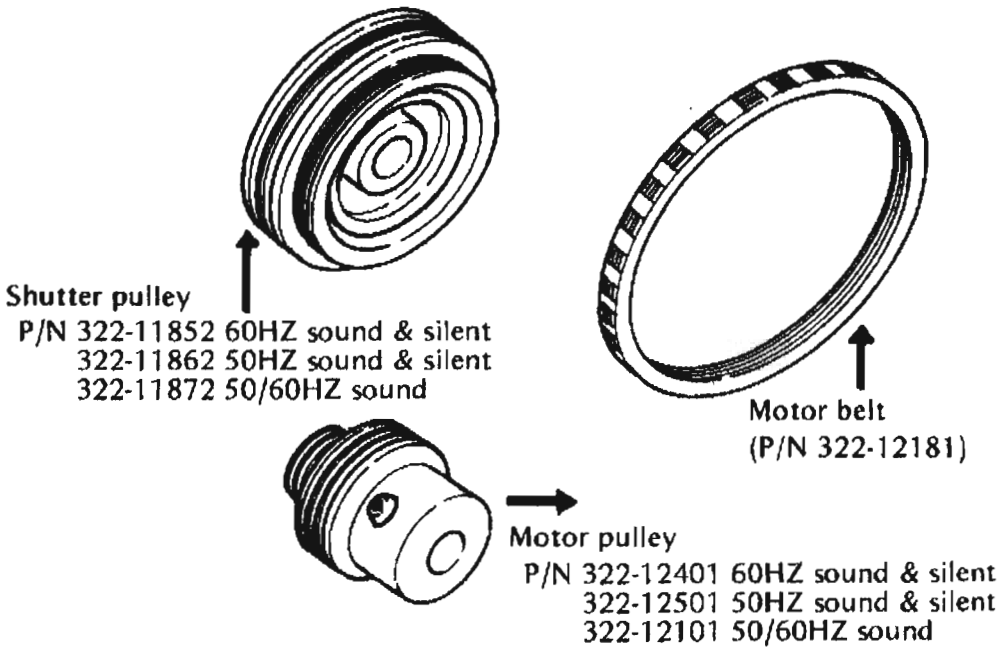

**ORDER #    ADDITIONAL LENSES AVAILABLE**

5059	12.5mm (1/2")	F1.4
5060	25.0mm (1")	F1.5
5061	38.0mm (1-1/2")	F1.5
5019	50.0mm (2")	F1.2 (Standard)
5062	65.0mm (2.5")	F1.5
5063	75.0mm (3")	F1.8
5064	75.0mm (3")	F1.8 Tele-Cine Lens
5066	100.0mm (4")	
5024	Zoom Conversion Lens "C" size (x 0.75 to x 1.25)	
5067	Zoom Conversion Lens 16-S "D" size (x 0.75 to x 1.30)	
5026	Wide-angle or Telephoto Conversion Lens (x 0.8 to x 1.25)	

# SPECIAL APPLICATIONS

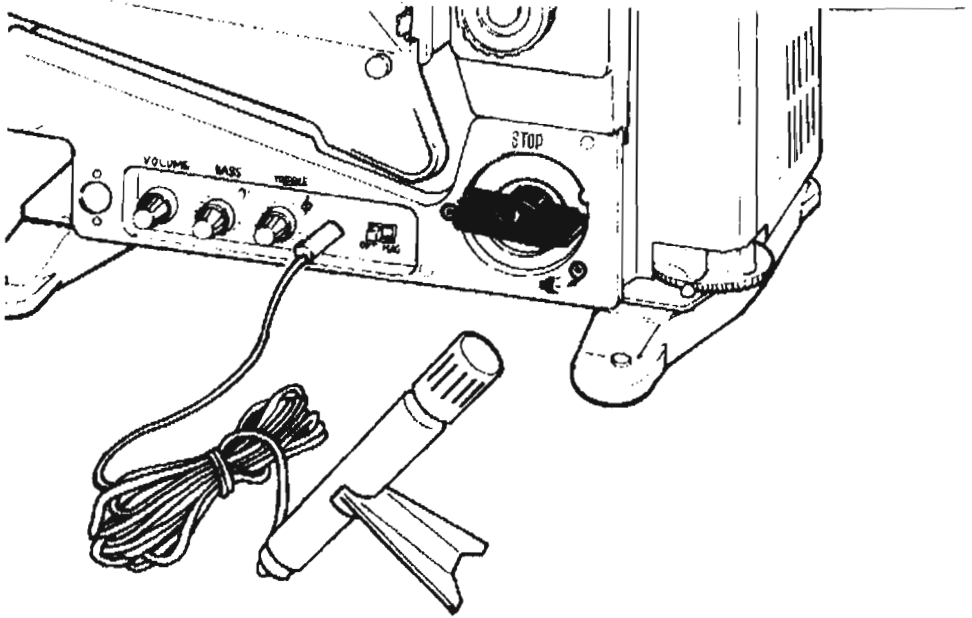

## A. USING PROJECTOR AS A P.A. SYSTEM.

To use the projector as a public address system, simply plug an accessory microphone into the amplifier MIC jack.

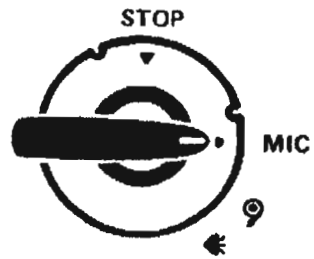

Advance the projector function switch clockwise to the position marked MIC. Adjust the volume and tone controls as necessary.

**NOTE:** It is recommended that the P.A. MIC be used with the projector plugged into the external speakers, and that the speakers be located away from the projector.

Models 3575 require that the motor runs before the amplifier can be used as a P.A.



## B. MAGNETIC SOUND TRACK PLAYBACK (Models 3580-2 Only)

To reproduce a previously recorded magnetic sound track switch the Opt/ Mag switch to the right. Projector may then be operated as usual.

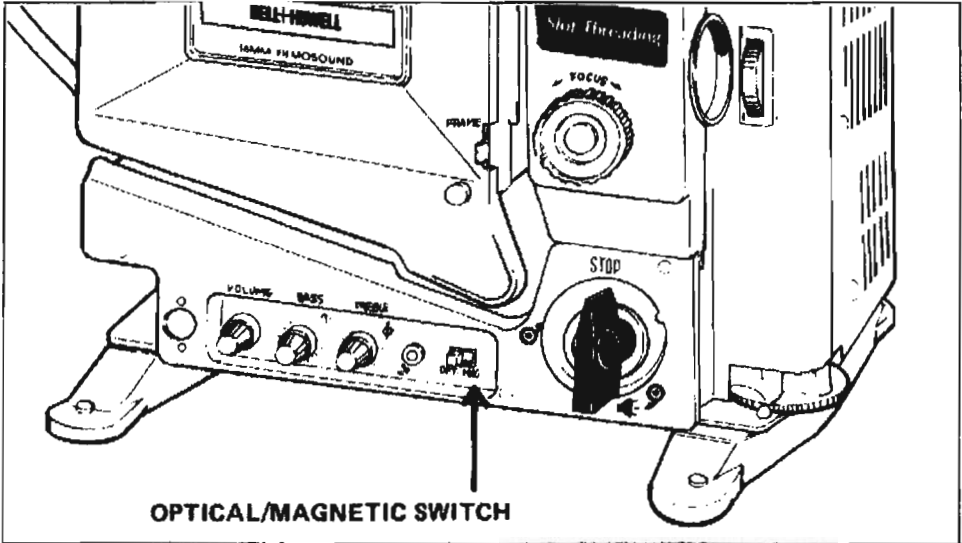

Since the majority of films are optical it is a good idea to return the switch to optical for the next user.

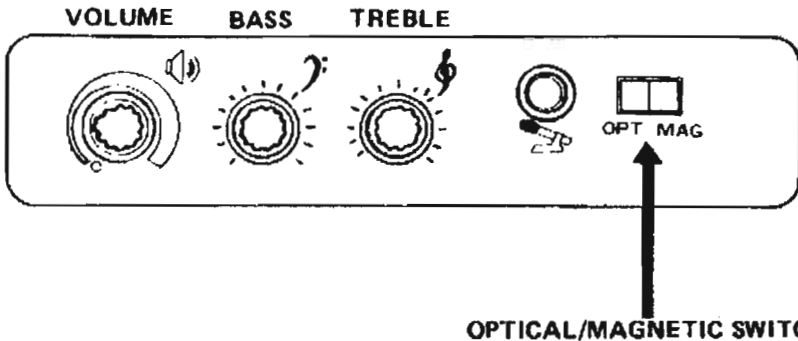

**C. 50HZ to 60HZ CONVERSION**

The standard 3580 projector is available as 50HZ or 60HZ sound speed operations. Conversion from 50 to 60HZ or 60 to 50HZ can be accomplished by changing the motor belt.

To allow the projector to be operated at either 50 or 60HZ sound and silent, it is necessary to change the motor pulley.

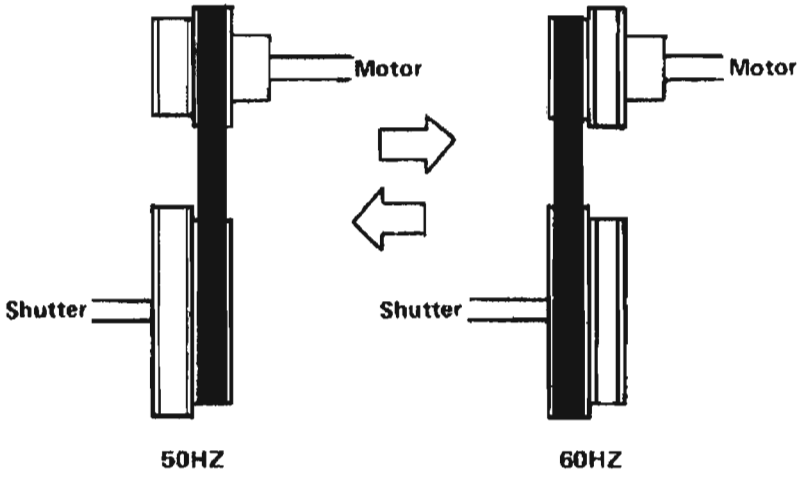

#### D. MULTIPLE VOLTAGE APPLICATIONS (OPTIONAL MODELS)

In many countries where more than one electrical power source is common, special models with selective voltage requirements are available. To select the appropriate voltage, remove the lamp house cover as indicated in the lamp replacement procedure. In the lower left hand corner of the lamp house is a selector plug.

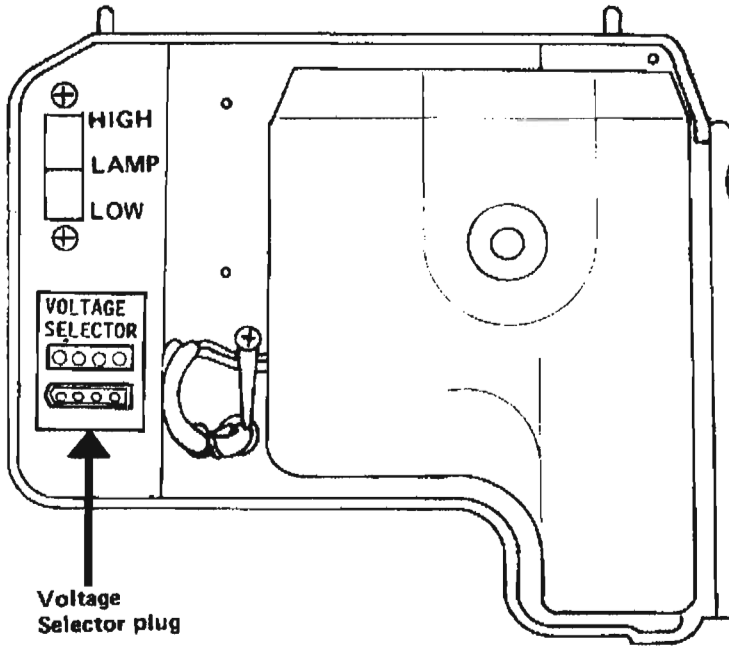

Select the appropriate voltage prior to plugging in the projector. When returning the projector to an area using higher voltage be sure to switch it to the correct voltage before plugging it in.

**NOTE:** This feature not available on Models 3575 with the 120V, 300W (EYK) lamp.

## E. SILENT FILM OPERATION

Models fitted with optional two-position motor and shutter pulleys may be shifted from 24 FPS sound speed to 18 FPS silent by following the steps below.



1. Remove the rear cover. Turn inching knob, at the same time guiding the belt, first to the smaller motor pulley, then to the larger shutter pulley.
2. To change back to sound speed reverse the procedure.

NOTE: 50/60HZ models do not have silent speed.

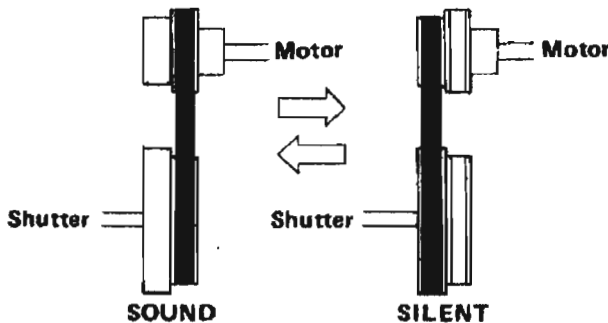
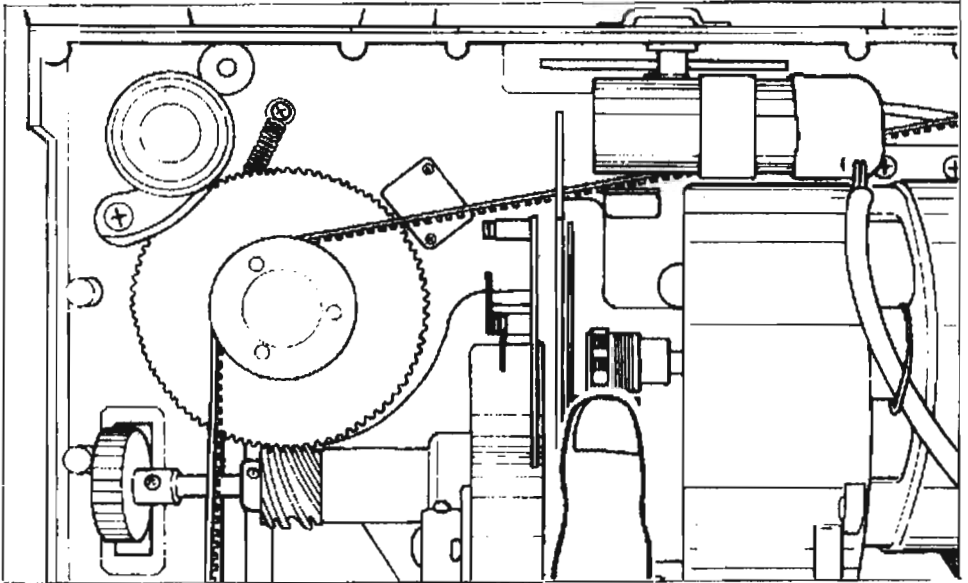

# CLEANING AND MAINTENANCE

The **BELL&HOWELL** projector has been designed to provide years of trouble free services.

All maintenance such as lubrications and adjustments should be referred to a qualified service technician.

To keep your projector looking and operating like new the following items should be checked and cleaned by the operator.

1. Lens — Clean with soft lens tissue.

2. Film gate and aperture plate —

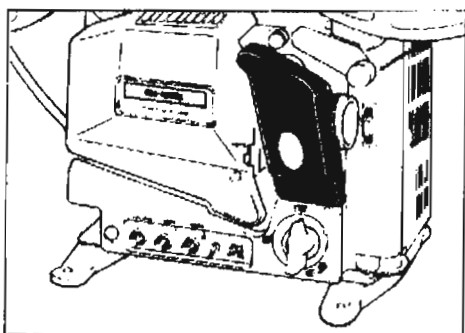

a. Remove lens holder mechanism cover by pulling out from the top as shown.

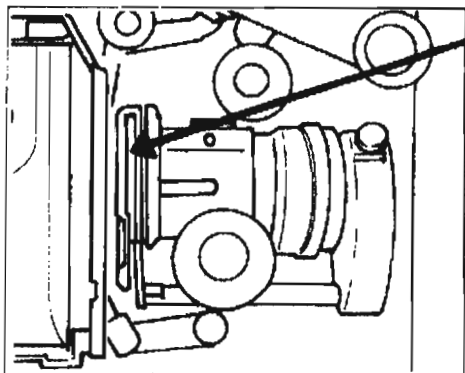

b. Pull film shoe and bracket assembly out from the top.

c. Brush clean with a soft brush and re-install.

3. Film rollers — Clean and wipe dry with isopropyl alcohol.

4. Sound focus lens — Brush or blow off dust and lint.

5. Projector — Wipe off covers with a damp cloth and keep them closed when projector is not in use.

The front elevated feet should always be up before transporting or storing the projector.

Do not oil or lubricate any part of this projector. Refer to your authorized service dealer.

# OPERATOR TROUBLE SHOOTING GUIDE

SYMPTOM	CHECK
<b>No power to motor or lamp (Pilot lamp not on)</b>	<ol style="list-style-type: none"><li>1. Be sure projector is plugged in and the outlet has power</li><li>2. Check power cord</li><li>3. Film guard switch not re-set (See projecting instructions)</li></ol>
<b>Motor runs but film doesn't advance</b>	<ol style="list-style-type: none"><li>1. Motor belt off or broken</li><li>2. Run/Still switch in still.</li></ol>
<b>Motor runs too fast or too slow</b>	<ol style="list-style-type: none"><li>1. Belt not on the correct motor pulley</li></ol>
<b>Motor runs, film advances, lamp does not come on</b>	<ol style="list-style-type: none"><li>1. Function switch not in FORWARD/RUN position</li><li>2. Defective lamp</li></ol>
<b>Won't load properly</b>	<ol style="list-style-type: none"><li>1. Function switch not in the STOP position (Refer to loading instructions)</li><li>2. Film gate not properly in place</li></ol>
<b>No sound (Exciter lamp on)</b>	<ol style="list-style-type: none"><li>1. Amplifier volume control not turned up</li><li>2. On magnetic playback models make sure switch is in the correct position</li><li>3. Function switch not in position FORWARD.</li><li>4. 2 amp amplifier fuse defective</li></ol>

SYMPTOM	CHECK
No sound (Exciter lamp not on)	<ol style="list-style-type: none"> <li>1. Amplifier volume control not turned on</li> <li>2. Defective exciter lamp</li> <li>3. 2 amp exciter lamp fuse defective</li> </ol>
Poor sound	<ol style="list-style-type: none"> <li>1. Check position of volume control</li> <li>2. Check position of tone controls</li> <li>3. Clean exciter lamp</li> <li>4. Check for dirt in the solar cell</li> <li>5. Check film. May be defective</li> <li>6. Incorrect exciter lamp</li> <li>7. Speaker defective</li> </ol>
Poor picture	<ol style="list-style-type: none"> <li>1. Remove and clean film gate and aperture</li> <li>2. Clean lens with a soft tissue, both front and rear</li> <li>3. Refocus lens</li> <li>4. Film may be defective</li> </ol>
Poor illumination	<ol style="list-style-type: none"> <li>1. Hi-low lamp switch in low position.</li> <li>2. Incorrect Lamp.</li> <li>3. Defective lamp.</li> </ol>

**Distributed by;  
EIKI INTERNATIONAL, INC.**

BELL&HOWELL Audio Visual/Video Products  
27882 Camino Capistrano, P.O. Box 30000  
Laguna Niguel, CA 92677-8000  
Phone: (714) 582-2511 FAX: (714) 364-6405  
or 2230 Brummel Place, Evanston, IL 60202  
Phone: (312) 328-3001

**Manufactured by;  
Eiki Industrial Co., Ltd. Osaka, Japan**

Printed in Japan