



**When the show must go on.**

E I K I  
P/N: 4400

**16MM SOUND PROJECTOR**

# **SERVICE MANUAL**

**- MODEL "N" SERIES -**

**May. 1.1980**

**EIKI INDUSTRIAL CO., LTD.  
C.P.O. BOX 1229 OSAKA JAPAN  
(06) 311-9475**

**EIKI INTERNATIONAL, INC.  
27882 Camino Capistrano  
Laguna Niguel, California 92677  
(714) 831-2511**

**Authorized EIKI Distributor or Dealer:**

# TABLE OF CONTENTS

"N" Series

Title	PAGE
INTRODUCTION	
314-1: PRINCIPLES OF OPERATIONS	
1-1 Introduction . . . . .	15
1-2 Mechanical System . . . . .	15
1-3 Electrical System . . . . .	15
1-4 Sound System . . . . .	15
314-2: SERVICE PROCEDURES	
2-1 Precautions . . . . .	17
2-2 Tools And Test Equipment . . . . .	17
2-3 Lubricants And Lubrication Charts . . . . .	18
2-4 Troubleshooting Hints . . . . .	24
314-3: MODULE REMOVAL AND INSTALLATION	
3-1 Cam Tank Module . . . . .	25
3-2 Amplifier Module . . . . .	25
3-3 Motor Module . . . . .	26
3-4 Transformer Module . . . . .	26
3-5 Lens Holder And Gate Module . . . . .	26
314-4: MODULE REPAIR AND ADJUSTMENTS	
4-1 Cam Tank Module . . . . .	27
A. Specifications . . . . .	27
B. Disassembly . . . . .	27
C. Re-Assembly . . . . .	28
D. Adjustments	
1. Claw Protrusion . . . . .	28
2. Claw Position And Framing . . . . .	29
E. Claw Replacement . . . . .	30
F. Changing Shutter Blades . . . . .	31
G. Still Picture Clutch . . . . .	32
4-2 Amplifier Module	
A. Specifications . . . . .	33
B. Power Supply Circuit . . . . .	33
C. Audio Amplifier Circuit . . . . .	33
D. Magnetic Record Amplifier . . . . .	34
E. Amplifier Circuit Diagrams . . . . .	34
4-3 Motor Module	
A. Specifications . . . . .	39
B. Motor Circuit Diagram . . . . .	39
C. Connector Wiring Code . . . . .	39
D. Silent Film Operation And 50 ↔ 60Hz Conversion . . . . .	40
4-4 Transformer Module	
A. Transformer Circuit Diagram . . . . .	41
B. Connector Wiring Code . . . . .	41
4-5 Lens Holder And Gate Module	
A. Film Gate Assy . . . . .	43
B. Film Shoe and Lens Holder Assy . . . . .	43
314-5: GENERAL MECHANICAL SERVICING AND ADJUSTMENTS	
5-1 Take-Up Arm	
A. Description . . . . .	47
B. Adjustments . . . . .	47

# TABLE OF CONTENTS

"N" Series

Title	PAGE
5-2 Supply Arm	
A. Description .....	48
B. Adjustments .....	49
5-3 Reverse Projection	
A. Description .....	49
B. Adjustments .....	49
5-4 Lower Loop Setter System	
A. Description .....	50
B. Adjustments .....	50
5-5 Self Threading Mechanism	
A. Description .....	52
B. Adjustments .....	55
1) #1 Sprocket shoe assembly .....	55
2) #1 Film guide .....	55
3) Retraction of the claw .....	56
4) #2 Film guide .....	56
5) Sound drum rubber pinch roller .....	56
6) Tension guide and roller assembly .....	57
7) #2 Sprocket and shoe assembly .....	58
5-6 Rewind Mechanism	
A. Description .....	59
B. Adjustments .....	59
5-7 Sound Drum And Flywheel	
A. Description .....	59
B. Adjustments .....	60
314-6: SOUND PICK-UP SYSTEM	
6-1 Optical Sound Focusing Procedure	
A. Description .....	61
B. Alignment .....	61
1) Tools and equipment .....	61
2) Set-up procedure .....	61
3) Sound focus adjustment .....	61
4) Buzz track adjustment .....	62
6-2 Magnetic Sound Playback System	
A. Description .....	63
B. Alignment .....	63
1) Tools and equipment .....	63
2) Set-up procedure .....	63
314-7: LAMP CIRCUIT	
7-1 Lamp Circuit .....	65
A. Description .....	65
B. Replacement and alignment .....	65
314-8: ELECTRICAL SYSTEM	
8-1 Electrical System .....	65
A. Function Control Switch .....	65
B. Electrical Circuit Diagram .....	65
314-9: SERVICE UPDATES AND MODIFICATIONS	
Attachment: CIRCUIT DIAGRAMS .....	67 ~ 79

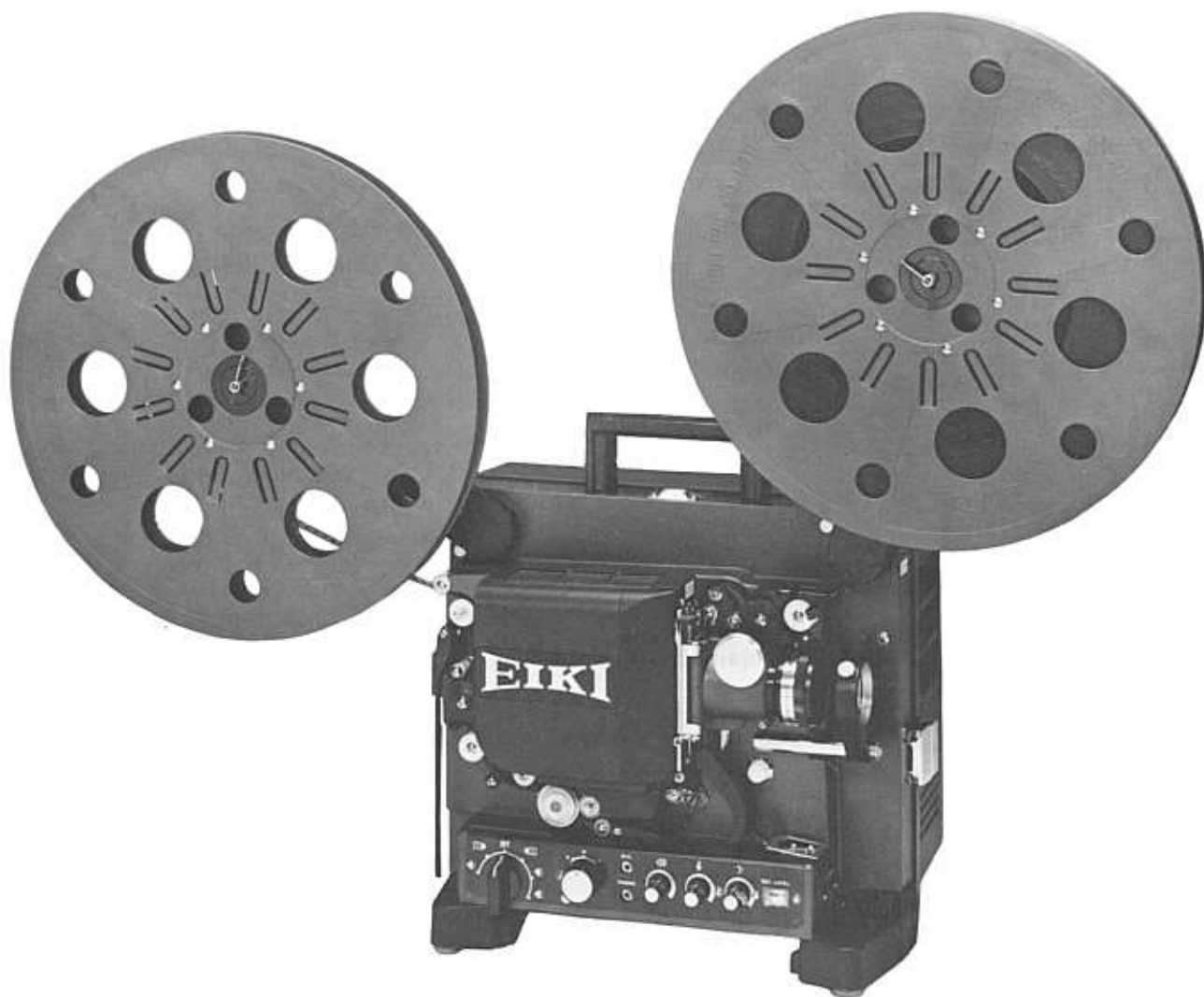

## INTRODUCTION

1. This Service Manual provides the necessary informations for the repair, adjustment, and maintenance of EIKI NST/NT-series projectors, model NST-0, NST-1, NST-2, NST-3, NT-0, NT-1, NT-2, and NT-3, and also EX-2000-N series except for the Xenon lamp supply.
2. This service manual contains some part numbers for convenience in identification only. When ordering replacement parts, refer to NST/NT replacement parts list.
3. EIKI NST/NT-series projectors may in the future be improved or modified.  
Modifications made after the issue of this manual will be covered by Service Updates.
4. A copy of all of the pertinent diagrams are attached at the end of this manual.
5. CAUTION! Care must be exercised to avoid electrical shock while servicing the projector.

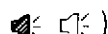

# "N"SERIES TROUBLE SHOOTING CHART

## I: ELECTRICAL SYSTEM

SYMPTOM	PROBABLE CAUSE	REMEDY
1. Pilot lamp not on	<ol style="list-style-type: none"> <li>1. No power to the AC wall outlet</li> <li>2. Defective power cord</li> <li>3. Faulty transformer or connection</li> <li>4. Defective pilot lamp</li> </ol>	<ol style="list-style-type: none"> <li>1. Check outlet</li> <li>2. Check &amp; repair or replace</li> <li>3. Repair or replace (See Sec 4-4)</li> <li>4. Replace</li> </ol>
2. Pilot lamp on, motor does not run in "forward" position (  )	<ol style="list-style-type: none"> <li>1. Defective motor module</li> <li>2. Defective or open motor connections</li> <li>3. Faulty motor capacitor</li> <li>4. Switch cam not activating micro switch #1</li> <li>5. Defective micro switch #1</li> <li>6. Motor thermal switch open. (UL &amp; CSA type)</li> </ol>	<ol style="list-style-type: none"> <li>1. Replace or repair (See Sec 4-3)</li> <li>2. Check &amp; repair, or replace (See Sec 4-3-C)</li> <li>3. Check &amp; replace (See Sec 4-3)</li> <li>4. Check &amp; adjust (See Sec 8-1-A)</li> <li>5. Check &amp; replace (See Sec 8-1-A)</li> <li>6. Allow motor to cool and check again.</li> </ol>
3. Pilot lamp on, motor runs but the lamp does not come on in "forward lamp" position (  )	<ol style="list-style-type: none"> <li>1. Defective lamp</li> <li>2. Lamp not seated properly in the socket</li> <li>3. Defective lamp socket</li> <li>4. Defective micro switch #4 or #5 on the function control</li> <li>5. Open transformer connection</li> <li>6. Defective transformer module</li> </ol>	<ol style="list-style-type: none"> <li>1. Replace lamp</li> <li>2. Check &amp; reseal</li> <li>3. Repair or replace</li> <li>4. Check &amp; replace (See Sec 8-1-A)</li> <li>5. Check &amp; repair (See Sec 4-4-B)</li> <li>6. Replace (See Sec 4-4)</li> </ol>
4. Pilot lamp on, motor runs in "forward", but not in "reverse" position (  )	<ol style="list-style-type: none"> <li>1. Micro switch #2 and/or #3 defective</li> <li>2. Defective motor module</li> </ol>	<ol style="list-style-type: none"> <li>1. Check or replace (See Sec 8-1-A)</li> <li>2. Replace (See Sec 4-3)</li> </ol>
5. Function switch does not follow the indicated sequence	<ol style="list-style-type: none"> <li>1. Loose function switch knob</li> <li>2. Loose switch cam</li> <li>3. Reverse or take-up clutch cam's installed incorrectly</li> </ol>	<ol style="list-style-type: none"> <li>1. Re-locate and tighten</li> <li>2. Re-position and tighten</li> <li>3. Check and repair (See Sec 5-1, &amp; 5-3)</li> </ol>

II: SELF-THREADING SYSTEM

SYMPTOM	PROBABLE CAUSE	REMEDY
6. #2 film guide (or self-thread lever) does not set the mechanism to thread	<ol style="list-style-type: none"> <li>1. Cam bracket is loose on the #2 film guide shaft</li> <li>2. Main interlocking bracket is binding or not latching with the release bracket hook</li> </ol>	<ol style="list-style-type: none"> <li>1. Re-position and tighten (See Sec 5-5-B4)</li> <li>2. Check &amp; adjust (See Sec 5-5-B)</li> </ol>
7. Leader or film is dimpled in the first few inches by the sprocket teeth	<ol style="list-style-type: none"> <li>1. Film is inserted with the sprocket holes opposite the sprocket teeth</li> <li>2. Not enough clearance between the sprocket plate and the film shoe</li> <li>3. Film path and #2 sprocket drive out of alignment</li> <li>4. Film leader too soft</li> </ol>	<ol style="list-style-type: none"> <li>1. Re-insert the film correctly</li> <li>2. Check &amp; adjust (See Sec 5-5-B1).</li> <li>3. Check alignment of the tension guide rollers (See Sec 5-5-B6)</li> <li>4. Check with another film leader.</li> </ol>
8. Leader jams in the #1 film guide	<ol style="list-style-type: none"> <li>1. Film leader not trimmed properly</li> <li>2. End of film is severely curled, or twisted.</li> <li>3. Very soft leader</li> <li>4. #1 film guide shaft loose or bent</li> <li>5. Aperture plate assembly misaligned</li> </ol>	<ol style="list-style-type: none"> <li>1. Trim and repeat threading</li> <li>2. Straighten and re-thread</li> <li>3. Replace leader</li> <li>4. Re-align and check. (See Sec 5-5-B2)</li> <li>5. Re-align and check (See Sec 4-5).</li> </ol>
9. Tip of the leader enters underneath the inner guide rail	<ol style="list-style-type: none"> <li>1. Inner guide rail bent or not aligned correctly</li> <li>2. Loose guide rail screws</li> <li>3. Film leader end severely curled or twisted.</li> </ol>	<ol style="list-style-type: none"> <li>1. Align or replace (See Sec 4-5)</li> <li>2. Tighten (See Sec 4-5)</li> <li>3. Trim and re-thread</li> </ol>
10. Film does not thread through the gate, and jams	<ol style="list-style-type: none"> <li>1. Film leader not trimmed properly</li> <li>2. Leader is severely curled or twisted, or too soft</li> <li>3. Too much #1 film shoe clearance</li> <li>4. Dirty and obstructed film gate</li> <li>5. Insufficient side travel of the inner guide rail</li> <li>6. Side pressure spring tension too strong</li> <li>7. Film shoe is not retracted during threading</li> </ol>	<ol style="list-style-type: none"> <li>1. Trim</li> <li>2. Trim, straighten or replace</li> <li>3. Check &amp; adjust (See Sec 5-5-B1)</li> <li>4. Clean &amp; check</li> <li>5. Check &amp; adjust (See Sec 4-5)</li> <li>6. Check &amp; adjust (See Sec 4-5)</li> <li>7. Check &amp; adjust (See Sec 4-5)</li> </ol>

(SELF-THREADING SYSTEM)

SYMPTOM	PROBABLE CAUSE	REMEDY
11. Chattering noise during threading	1. Claw is not completely retracted	1. Check & adjust (See Sec 5-5-B3)
12. Clicking noise during threading	1. Claw is hitting the shutter blade	1. Check & adjust (See Sec 5-5-B3)
13. Curled film goes over the loop setter roller	1. Loop setter position is too low 2. Severely curled film	1. Check & adjust (See Sec 5-4) 2. Straighten the lead end
14. Film goes under the #3 film guide or comes out	1. #2 Film guide defective 2. #3 Film guide defective 3. #2 and #3 film guides are not aligned 4. Curled film	1. Replace 2. Replace 3. Check & adjust (See Sec 5-5-B4) 4. Straighten the lead end
15. Film will not thread over the sound drum	1. Rough surface on the lamp house casting, restricting the film travel 2. Rubber pinch roller not completely released from the sound drum 3. Rubber pinch roller bound up or out of alignment	1. Remove & inspect the casting guides 2. Check & adjust. (See Sec 5-5-B5) 3. Check, adjust and lubricate (See Sec 5-5-B5)
16. Film stops at the #2 sprocket	1. Rough surface or restriction to the film path on the lamp house casting 2. #2 sprocket teeth or cover plate loose. 3. Tension guide and roller assembly out of alignment 4. #2 sprocket shoe clearance is too tight	1. Remove the lamp house casting and inspect 2. Tighten and re-time (See Sec 5-4) 3. Check for correct film feeding from the sound drum to the #2 sprocket. (See Sec 5-5-B6) 4. Check and adjust (See Sec 5-5-B7)
17. Film comes out of the #2 sprocket shoe	1. #2 sprocket plate is loose 2. #2 sprocket shoe spring weak or missing	1. Tighten and check timing (See Sec 5-4) 2. Check & replace (See Sec 5-5-B7)
18. Self-threading mechanism not released with a tug on the film	1. Release bracket spring is too weak or broken 2. Release bracket pin binding	1. Check & adjust (See Sec 5-5-B) 2. Lubricate pin and adjust linkage (See Sec 5-5-B)
19. Film does not cross the auto-take-up guide (NST only)	1. Auto-take-up guide not aligned properly 2. Film twisted, or curled	1. Check & adjust. 2. Stretch, or replace the film leader.

III: MECHANICAL SYSTEM

SYMPTOM	PROBABLE CAUSE	REMEDY
20. Pilot lamp on, motor runs but film does not advance	<ol style="list-style-type: none"> <li>1. Still picture lever engaged</li> <li>2. Broken or defective motor belt</li> <li>3. Cam tank plate washer loose</li> <li>4. Motor pulley loose</li> <li>5. Main drive belt broken</li> </ol>	<ol style="list-style-type: none"> <li>1. Release to normal run position</li> <li>2. Check &amp; replace</li> <li>3. Tighten (See Sec 4-1-B)</li> <li>4. Tighten</li> <li>5. Replace</li> </ol>
21. Film speed is too slow or too fast	<ol style="list-style-type: none"> <li>1. Belt is installed incorrectly</li> <li>2. Incorrect motor and shutter pulley combination</li> </ol>	<ol style="list-style-type: none"> <li>1. Check &amp; re-install</li> <li>2. Replace with correct pulleys (See Sec 4-3-D)</li> </ol>
22. Film comes out of the path near the sound drum	<ol style="list-style-type: none"> <li>1. Rubber pinch roller is binding</li> <li>2. Rubber roller and tension guide out of alignment</li> <li>3. #2 sprocket shoe not seating properly</li> </ol>	<ol style="list-style-type: none"> <li>1. Remove, lubricate and adjust (See Sec 5-5-B5)</li> <li>2. Check &amp; adjust (See Sec 5-5-B6)</li> <li>3. Check &amp; adjust (See Sec 5-5-B7)</li> </ol>
23. Excessive take-up torque in "forward"	<ol style="list-style-type: none"> <li>1. Dry cork of spindle assy</li> <li>2. Dirty or sticky take-up arm belt, or take-up pulley</li> </ol>	<ol style="list-style-type: none"> <li>1. Lubricate cork (See Sec 5-1)</li> <li>2. Clean or replace. (See Sec 5-1)</li> </ol>
24. Excessive take-up torque in "reverse"	<ol style="list-style-type: none"> <li>1. Reverse clutch spring too strong</li> </ol>	<ol style="list-style-type: none"> <li>1. Check &amp; adjust (See Sec 5-3)</li> </ol>
25. Take-up poor or not at all in "forward"	<ol style="list-style-type: none"> <li>1. Take-up arm belt broken, or stretched, or oily belt.</li> <li>2. Defective ball bearing.</li> <li>3. Loose spindle shaft</li> <li>4. Take-up pulley binding</li> <li>5. Excessive grease on take-up pulley</li> <li>6. Clutch cam defective.</li> <li>7. Too loose film on the take-up reel</li> </ol>	<ol style="list-style-type: none"> <li>1. Replace or clean.</li> <li>2. Replace.</li> <li>3. Tighten screw.</li> <li>4. Clean or replace</li> <li>5. Avoid over-lubrication</li> <li>6. Check &amp; replace, or reposition clutch cam. (See Sec 5-1)</li> <li>7. Check &amp; absorb extra film slack.</li> </ol>
26. Take-up poor or not at all in "reverse"	<ol style="list-style-type: none"> <li>1. Broken or stretched or oily supply arm belt</li> <li>2. Reverse belt broken or oily</li> <li>3. Clutch cam not engaging</li> <li>4. Reverse clutch spring weak</li> </ol>	<ol style="list-style-type: none"> <li>1. Replace</li> <li>2. Clean or replace</li> <li>3. Check &amp; repair (See Sec 5-3)</li> <li>4. Tighten knurled nut (See Sec 5-3)</li> </ol>



(MECHANICAL SYSTEM)

SYMPTOM	PROBABLE CAUSE	REMEDY
27. Weak back tension of the supply reel in "forward"	<ol style="list-style-type: none"> <li>1. Reverse clutch cover pulley binding and clutch cam is not releasing, or clutch cover pulley defective</li> <li>2. Clutch cover pulley has no end play on the #1 sprocket drum shaft.</li> <li>3. Clutch cam seated incorrect, or defective</li> <li>4. Clutch cam binding between clutch cover pulley and spacer</li> </ol>	<ol style="list-style-type: none"> <li>1. Check &amp; adjust, or replace. (See Sec 5-3)</li> <li>2. Check &amp; adjust. (See Sec 5-1)</li> <li>3. Check &amp; reposition, or replace. (See Sec 5-1)</li> <li>4. Check &amp; adjust</li> </ol>
28. Weak back tension of the take-up reel in "reverse"	<ol style="list-style-type: none"> <li>1. Drive gear is binding, or has no end play on the drive pulley shaft.</li> <li>2. Clutch cam seated incorrect, or binding between drive gear and clutch cover assy, or defective clutch cam</li> <li>3. Drive gear, or clutch cover defective</li> </ol>	<ol style="list-style-type: none"> <li>1. Check &amp; clean, or adjust. (See Sec 5-3)</li> <li>2. Check &amp; reposition (See Sec 5-1)</li> <li>3. Check &amp; replace</li> </ol>
29. Loop setter roller continues to activate, or activates erratically in "forward"	<ol style="list-style-type: none"> <li>1. Damaged or poor film</li> <li>2. Insufficient gear spring tension</li> <li>3. Loop setter roller in the wrong position.</li> <li>4. #2 sprocket plate loose</li> <li>5. Lower loop is too small</li> <li>6. Insufficient claw protrusion, or claw pitch.</li> <li>7. Broken claw</li> <li>8. Too much take-up tension</li> <li>9. Incorrect clearance between the loop setter gear and main drive belt</li> <li>10. Loop setter gear, or main drive belt defective, or broken</li> <li>11. Insufficient tension of the film shoe springs</li> </ol>	<ol style="list-style-type: none"> <li>1. Repair or replace</li> <li>2. Stretch or replace (See Sec 5-4-B)</li> <li>3. Relocate &amp; check (See Sec 5-4).</li> <li>4. Check &amp; tighten</li> <li>5. Check #2 sprocket timing (See Sec 5-4-B).</li> <li>6. Check (See Sec 4-1-D1)</li> <li>7. Check &amp; replace</li> <li>8. Check &amp; lubricate take-up spindle cork (See Sec 5-1)</li> <li>9. Adjust clearance (See Sec 5-4)</li> <li>10. Replace</li> <li>11. Stretch or replace.</li> </ol>

(MECHANICAL SYSTEM)

SYMPTOM	PROBABLE CAUSE	REMEDY
30. Film continues to flap on loop setter roller in "forward"	<ol style="list-style-type: none"> <li>1. Loop setter gear shaft is binding, or tight in hub.</li> <li>2. Loop setter gear spring tension too strong</li> </ol>	<ol style="list-style-type: none"> <li>1. Check &amp; lubricate</li> <li>2. Adjust spring tension, or replace.</li> </ol>
31. Lower loop is lost in "reverse"	<ol style="list-style-type: none"> <li>1. Reverse rubber roller is not driving the flywheel set collar</li> <li>2. Reverse rubber roller binding</li> <li>3. #2 sprocket not transporting film.</li> </ol>	<ol style="list-style-type: none"> <li>1. Check reverse rubber roller's function (See Sec 5-3)</li> <li>2. Clean &amp; remove the cause of binding</li> <li>3. Check &amp; adjust (See Sec 5-4)</li> </ol>
32. Upper loop is lost in "forward"	<ol style="list-style-type: none"> <li>1. Damaged, or poor film</li> <li>2. #1 sprocket teeth plate loose</li> <li>3. #1 sprocket shoe not seating properly.</li> <li>4. Loop setter roller continues to activate or activates erratically.</li> </ol>	<ol style="list-style-type: none"> <li>1. Repair or replace</li> <li>2. Check &amp; tighten.</li> <li>3. Check &amp; adjust. (See Sec 5-5-B1)</li> <li>4. See Symptom No. 29</li> </ol>
33. Upper loop is lost in "reverse"	<ol style="list-style-type: none"> <li>1. Damaged, or poor film</li> <li>2. #1 sprocket shoe clearance is too great.</li> <li>3. Claw protrusion incorrect</li> </ol>	<ol style="list-style-type: none"> <li>1. Repair, or replace</li> <li>2. Check &amp; adjust (See Sec 5-5-B1)</li> <li>3. Check &amp; adjust (See Sec 4-1-D1)</li> </ol>
34. Excessive noise in the film gate in "forward" with a good undamaged film	<ol style="list-style-type: none"> <li>1. Upper loop too small</li> <li>2. Film contacting the loop setter roller.</li> <li>3. Dirty film gate</li> <li>4. Loose claw</li> <li>5. Incorrect claw protrusion</li> <li>6. Inner guide rail binding</li> <li>7. Film shoe bent, worn or binding</li> <li>8. Claw position incorrect</li> <li>9. Weak or broken cam follower spring</li> </ol>	<ol style="list-style-type: none"> <li>1. Check #1 sprocket timing</li> <li>2. Check #2 sprocket and loop setter timing (See Sec 5-4-B)</li> <li>3. Clean</li> <li>4. Tighten</li> <li>5. Check</li> <li>6. Check &amp; adjust</li> <li>7. Check &amp; replace</li> <li>8. Check &amp; adjust (See Sec 4-1-D2)</li> <li>9. Replace (See Sec 4-1-B)</li> </ol>
35. Unsteady picture	<ol style="list-style-type: none"> <li>1. See Symptom No. 34, noise in the film gate</li> </ol>	
36. Travel ghost	<ol style="list-style-type: none"> <li>1. Incorrect shutter blade position</li> </ol>	<ol style="list-style-type: none"> <li>1. Check &amp; adjust (See Sec 4-1-F)</li> </ol>

(MECHANICAL SYSTEM)

SYMPTOM	PROBABLE CAUSE	REMEDY
37. Excessive noise in "reverse" only	<ol style="list-style-type: none"> <li>1. Claw position incorrect</li> <li>2. Claw angle is incorrect</li> </ol>	<ol style="list-style-type: none"> <li>1. Check &amp; adjust (See Sec 4-1-D2)</li> <li>2. Check &amp; adjust (See Sec 4-1-E)</li> </ol>
38. Insufficient framing	<ol style="list-style-type: none"> <li>1. Claw position incorrect</li> <li>2. Worn cam follower (or gliding pin)</li> </ol>	<ol style="list-style-type: none"> <li>1. Check &amp; adjust (See Sec 4-1-D2)</li> <li>2. Replace (See Sec 4-1-B)</li> </ol>
39. Excessive noise when the still picture lever is depressed	<ol style="list-style-type: none"> <li>1. Motor pulley misaligned</li> <li>2. Shutter pulley binding on the shaft</li> </ol>	<ol style="list-style-type: none"> <li>1. Adjust</li> <li>2. Remove, clean, inspect and lubricate (See Sec 4-1-G)</li> </ol>
40. Film transport does not stop in still picture operation	<ol style="list-style-type: none"> <li>1. Shutter pulley seized</li> <li>2. Still picture lever shoulder screws loose</li> </ol>	<ol style="list-style-type: none"> <li>1. Remove cam tank, clean &amp; lubricate pulley (See Sec 4-1-G)</li> <li>2. Tighten screws (See Sec 4-1-G)</li> </ol>
41. Film burns when still picture lever is depressed	<ol style="list-style-type: none"> <li>1. Still picture lever not completely depressed</li> <li>2. Heat filter misaligned or broken</li> </ol>	<ol style="list-style-type: none"> <li>1. Fully depress</li> <li>2. Check, realign or replace</li> </ol>
42. No rewind or poor rewind	<ol style="list-style-type: none"> <li>1. Take-up spindle cork too dry or tight</li> <li>2. Broken or stretched or oily supply arm belt</li> <li>3. Defective rewind gears</li> <li>4. Broken rewind arm tension spring</li> <li>5. Take-up pulley binding on the shaft</li> </ol>	<ol style="list-style-type: none"> <li>1. Remove and lubricate (See Sec 5-1)</li> <li>2. Check and replace</li> <li>3. Inspect &amp; replace</li> <li>4. Check &amp; replace (See Sec 5-6)</li> <li>5. Clean &amp; lubricate</li> </ol>
43. Noisy rewind	<ol style="list-style-type: none"> <li>1. Rewind gears not fully engaged.</li> <li>2. Worn or defective rewind gears.</li> </ol>	<ol style="list-style-type: none"> <li>1. Adjust the gear position (See Sec 5-6)</li> <li>2. Replace (See Sec 4-5)</li> </ol>
44. Uneven focus	<ol style="list-style-type: none"> <li>1. Dirty film gate</li> <li>2. Film shoe binding and not completely seated</li> <li>3. Inner guide rail binding</li> <li>4. Lens holder misaligned</li> </ol>	<ol style="list-style-type: none"> <li>1. Clean</li> <li>2. Check &amp; realign (See Sec 4-5-B)</li> <li>3. Check (See Sec 4-5)</li> <li>4. Check &amp; adjust (See Sec 4-5)</li> </ol>

IV: LAMP CIRCUIT

SYMPTOM	PROBABLE CAUSE	REMEDY
45. Lamp life is abnormally short	<ol style="list-style-type: none"> <li>1. Poor lamp socket connection.</li> <li>2. Cooling is restricted</li> <li>3. Defective lamps, or incorrect lamp other than EIKI ELC type</li> <li>4. Excessive or fluctuating AC line voltage</li> </ol>	<ol style="list-style-type: none"> <li>1. Replace lamp socket</li> <li>2. Locate &amp; remove the cause.</li> <li>3. Check &amp; replace.</li> <li>4. Check AC line.</li> </ol>
46. Uneven or insufficient screen illumination	<ol style="list-style-type: none"> <li>1. Lamp not seated properly</li> <li>2. Foreign object in the light path</li> <li>3. Lamp not centered horizontally</li> <li>4. Defective lamps, or incorrect lamp other than EIKI ELC type</li> <li>5. Function switch in "low" position</li> <li>6. Slow or defective lens</li> <li>7. Low AC line voltage</li> <li>8. Improper shutter</li> </ol>	<ol style="list-style-type: none"> <li>1. Check &amp; reseat</li> <li>2. Remove</li> <li>3. Adjust knurled knob</li> <li>4. Check &amp; replace</li> <li>5. Switch to "high" position.</li> <li>6. Try another lens</li> <li>7. Check AC line</li> <li>8. Check or replace.</li> </ol>

V: SOUND SYSTEM

SYMPTOM	PROBABLE CAUSE	REMEDY
47. No sound and the exciter lamp is not on	<ol style="list-style-type: none"> <li>1. Amplifier is not turned on.</li> <li>2. 9 pin amplifier plug defective</li> <li>3. Defective exciter lamp</li> <li>4. Defective exciter lamp socket</li> <li>5. Exciter lamp fuse blown</li> <li>6. Defective amplifier module</li> <li>7. Defective exciter lamp power supply of the transformer</li> </ol>	<ol style="list-style-type: none"> <li>1. Turn on.</li> <li>2. Check &amp; repair, or replace.</li> <li>3. Replace</li> <li>4. Repair or replace</li> <li>5. Check &amp; replace</li> <li>6. Replace, or repair (See Sec 3-2, &amp; 4-2)</li> <li>7. Locate &amp; repair, or replace. (See Sec 4-4)</li> </ol>
48. No sound, exciter lamp is on	<ol style="list-style-type: none"> <li>1. Amplifier volume is too low.</li> <li>2. Mag/Opt switch in the wrong position (NST/NT-2,-3 models only)</li> <li>3. Rear cover speaker not plugged in (not applicable on NST/NT-3 models), or extension speakers not connected.</li> <li>4. Defective rear cover speaker, or extension speaker, or speaker jack.</li> <li>5. Amplifier fuse blown</li> <li>6. Defective solar cell or connections</li> <li>7. Dirt or foreign object in the optical sound lens</li> <li>8. Defective amplifier module</li> </ol>	<ol style="list-style-type: none"> <li>1. Check &amp; adjust.</li> <li>2. Check &amp; switch</li> <li>3. Check &amp; connect.</li> <li>4. Repair or replace.</li> <li>5. Replace</li> <li>6. Repair or replace (See Sec 4-2)</li> <li>7. Clean.</li> <li>8. Locate &amp; repair, or replace (See Sec 3-2 &amp; 4-2)</li> </ol>
49. Poor sound or low volume	<ol style="list-style-type: none"> <li>1. Incorrect, or defective exciter lamp, or sound lens.</li> <li>2. Dirty exciter lamp, or sound lens, or dirt, foreign object in the optical sound lens</li> <li>3. Sound optics incorrectly aligned.</li> <li>4. Low exciter lamp voltage, or low AC supply voltage.</li> <li>5. Weak or defective solar cell.</li> <li>6. Defective speakers, or poor speaker connection</li> <li>7. Poor film quality</li> <li>8. Defective amplifier module</li> </ol>	<ol style="list-style-type: none"> <li>1. Check &amp; replace</li> <li>2. Clean, or replace.</li> <li>3. Check &amp; re-align sound pick-up system (See Sec 6-1)</li> <li>4. Check &amp; repair amplifier exciter lamp supply. (See Sec 4-2). Check wall outlet.</li> <li>5. Replace.</li> <li>6. Check &amp; replace</li> <li>7. Check with another film.</li> <li>8. Repair or replace. (See Sec 3-2, &amp; 4-2)</li> </ol>

(SOUND SYSTEM)

SYMPTOM	PROBABLE CAUSE	REMEDY
50. No sound (magnetic only) (NST/NT-2, -3 models)	<ol style="list-style-type: none"> <li>1. Mag/Opt switch in the wrong position.</li> <li>2. Magnetic head not in contact with the sound track</li> <li>3. Defective or dirty magnetic head</li> <li>4. Mag/Opt switch defective, or bad connection</li> <li>5. Defective speakers, or speaker connections</li> <li>6. Defective amplifier module</li> </ol>	<ol style="list-style-type: none"> <li>1. Check &amp; switch.</li> <li>2. Check &amp; adjust.</li> <li>3. Clean, or replace.</li> <li>4. Check &amp; replace</li> <li>5. Check &amp; replace.</li> <li>6. Repair or replace (See Sec 4-2 &amp; 3-2)</li> </ol>
51. Poor sound or low volume (magnetic only) (NST/NT-2, -3 models)	<ol style="list-style-type: none"> <li>1. Poor sound track.</li> <li>2. Dirty, or defective head</li> <li>3. Head not making good contact with the film</li> <li>4. Incorrect sound head alignment</li> <li>5. Defective speakers, or poor speaker connection</li> <li>6. Defective amplifier module</li> </ol>	<ol style="list-style-type: none"> <li>1. Check with another film.</li> <li>2. Clean or replace.</li> <li>3. Adjust (See Sec 6-2)</li> <li>4. Align (See Sec 6-2)</li> <li>5. Check &amp; replace</li> <li>6. Repair or replace (See Sec 4-2 &amp; 3-2)</li> </ol>
52. Exciter lamp fuse blows	<ol style="list-style-type: none"> <li>1. Excessive AC line voltage</li> <li>2. Incorrect fuse</li> <li>3. Incorrect, or defective exciter lamp</li> <li>4. Defective exciter lamp power supply</li> <li>5. Defective exciter lamp socket</li> </ol>	<ol style="list-style-type: none"> <li>1. Check wall outlet.</li> <li>2. Check &amp; replace.</li> <li>3. Check &amp; replace.</li> <li>4. Check &amp; repair (See Sec 4-2)</li> <li>5. Replace</li> </ol>
53. Amplifier fuse blows.	<ol style="list-style-type: none"> <li>1. Incorrect fuse</li> <li>2. Improper connection to an external speaker system</li> <li>3. Defective amplifier module</li> </ol>	<ol style="list-style-type: none"> <li>1. Check &amp; replace</li> <li>2. Check</li> <li>3. Repair or replace (See Sec 4-2 &amp; 3-2)</li> </ol>
54. Excessive amplifier hum (optical)	<ol style="list-style-type: none"> <li>1. Exciter lamp cover missing or not installed correctly.</li> <li>2. Incorrect grounding when connecting the projector to an external amplifier or sound system</li> <li>3. Defective exciter lamp supply</li> <li>4. Defective solar cell or connections to amplifier.</li> </ol>	<ol style="list-style-type: none"> <li>1. Install cover</li> <li>2. Check for ground loop conditions.</li> <li>3. Check voltage and repair. (See Sec 4-2)</li> <li>4. Check &amp; repair</li> </ol>

— to be continued —

(SOUND SYSTEM)

SYMPTOM	PROBABLE CAUSE	REMEDY
54. Excessive amplifier hum (optical) — continued —	5. Front or rear cover speaker jacks not insulated from the chassis properly 6. Defective amplifier module	5. Check & repair. 6. Repair or replace (See Sec 4-2 & 3-2)
55. Excessive amplifier hum (magnetic)	1. Poor film recording 2. Motor shield not installed 3. Improper connection to an external amplifier or sound system. 4. Magnetic head in poor contact with the film. 5. Poor shielding to the head or the head coil shorted to the projector's frame 6. Defective amplifier module	1. Check with another film. 2. Check & install. 3. Check & re-connect properly  4. Adjust (See Sec 6-2) 5. Repair  6. Repair or replace (See Sec 4-2 & 3-2)
56. Distorted sound	1. Incorrect exciter lamp. 2. Exciter lamp cover not completely installed 3. Amplifier module is defective 4. Defective speaker 5. Magnetic sound recorded poorly 6. Optical sound lens not aligned correctly 7. Dirt on the sound drum or on the solar cell 8. See Symptom No. 57 also.	1. Check & replace 2. Check & re-install  3. Replace 4. Replace 5. Try a known good recording  6. Check & realign (See Sec 6-1) 7. Check & clean  8. See Symptom No. 57
57. Excessive wow & flutter	1. Rubber pinch roller binding  2. Sound drum bearings defective 3. Reverse rubber drive roller in contact with the set collar 4. Flywheel not installed 5. Flywheel rubbing on the power cord 6. Incorrect alignment or tension of the tension guide and roller assembly	1. Check, clean, lubricate & adjust (See Sec 5-5) 2. Check & replace (See Sec 5-7) 3. Check & adjust (See Sec 5-3) 4. Check 5. Check & adjust  6. Check & adjust (See Sec 5-5-B6)
58. Sound not stabilized soon after starting	1. Insufficient flywheel plate spring tension 2. Weak rubber pinch roller spring	1. Check & adjust (See Sec 5-7) 2. Check & replace (See Sec 5-5-B5)

## 314-1: PRINCIPLES OF OPERATIONS

### 1-1: INTRODUCTION

The EIKI "N" series self-threading projector is very similar to the earlier "R" series model with added improvements such as silent threading, flat response amplifier, lighter weight, etc. With few exceptions, such as color, most parts from the "N" series substitute directly into the previous "R" series. This manual also covers the NT manual threading models when excluding the sections on the threading mechanism.

### 1-2: MECHANICAL SYSTEM

The EIKI Self-threading projector is controlled by a single function switch for forward, reverse and high-low lamp positions.

#### A. THREADING:

Threading is accomplished by setting the threading guide lever to thread, function switch to forward and inserting the film into the threading channel. The threading mechanism is automatically released and engages the claw by a light tug of the film when attaching it to the take-up reel.

#### B. FORWARD/LAMP:

Advance the switch from forward to lamp low or high.

#### C. REVERSE:

To reverse the projector, return the function switch to "OFF" and then to reverse and lamp.

#### D. REWIND:

To rewind the film, engage the rewind lever. Attach the film to the empty supply reel and advance the function switch to "Forward".

### 1-3: ELECTRICAL SYSTEM

EIKI "N" series projectors are available in voltages of 100V, 110V, 120V, 220V and 240V. 110/220V and 120/240V dual voltage models are also available. To comply with electrical safety regulations of various countries, UL (USA), CSA (Canada), VDE (Germany), SEV (Switzerland), SAA (Australia), SEMKO (Sweden), NEMKO (Norway), FEMKO (Finland), DEMKO (Denmark), specific models are

manufactured to meet such regulations, including the option of 50Hz, 60Hz, 50/60Hz operation.

Power transformers vary according to the voltage range and also to the various electrical safety requirements. The secondary windings of all transformers provide 8V AC to the Pilot Lamp and Exciter Lamp circuits, 24V AC (HIGH) and 22V AC (LOW) to the Halogen Projection Lamp and 40V or 36V AC to the Amplifier.

(See Sec. 4-4 TRANSFORMER MODULE).

Motor ON/OFF and Lamp ON/OFF and reverse is controlled by the Function Switch which consists of a Cam and 5 micro switches.

The projection lamp is a Halogen ELC type 24V 250 watt. The "High-Low" position will extend the lamp life, depending upon operating conditions.

NOTE : The Halogen Lamp EJL type 24V 200W may also be used with some reduction in light output.

The motor is an induction type with capacitor. Motors are available for all the voltage ranges above. Optional Synchronous motor kits are also available for precise film speeds and tele-cine conversions.

Transformers and motors are simple and easy-to-replace modules. AC power cords, line terminals, and all other electrical parts are designed to meet the safety requirements of the countries listed.

### 1-4: SOUND SYSTEM

EIKI "N" series models are designated according to the sound playback and record capabilities with or without front cover extension speakers.

Optical Playback only: Model NST-0, -1 & NT-0, -1

Optical & Magnetic Playback: Model NST-2, NT-2

Optical & Magnetic Record/Playback:

Model NST-3, NT-3

Model NST-1, -2 & -3 and NT-1, NT-2 & NT-3 are standard with two (4 ohm, 12.5cm) speakers built-in the front cover. Models NST-1 & 2, and NT-1 & 2 are also standard with one (8 ohm, 12.5cm) speaker built-in the rear cover.

Models NST-0, and NT-0 are standard with one speaker only (8 ohm, 12.5cm) built-in the rear cover.

The standard amplifier modules for the NST-0



**"N" Series**  
(1-4)

& NT-0 and NST-1 & NT-1 are optical sound reproduction only.

Amplifier modules for the NST-2 and NT-2 are capable of both optical and magnetic sound reproduction.

Amplifier modules for the NST-3 and NT-3 are capable of both optical playback and magnetic record/playback.

## 2-1: PRECAUTIONS

1. EIKI "N" series projectors have been designed for the ultimate in simplicity and ease of service and repair. Each screw is very important, and when servicing or re-assembling the projector, screws should not be omitted or carelessly lost. All screws should be firmly tightened to assure reliable projector operation after re-assembly.
2. When lubricating the projector's plastic parts, silicon oil or grease should be used. Other types of lubricants may harm plastic parts. Avoid using any solvents such as Trichloroethylene, which will harm most plastic or painted parts.
3. EIKI projectors require a minimum of special tools. The most important is an ordinary ISO Phillips screw driver set.
4. To avoid damage to screw heads, it is important to remember the adage "70% push, 30% turn." It is also important to select the right size screw driver blade. A rule of thumb is to use the largest blade possible.
5. To avoid possible electrical shock, always disconnect the projector from the power source when servicing.

## 2-2: TOOLS AND TEST EQUIPMENT

A. Tools:

When servicing EIKI "N" series, ordinary ISO (Phillips type) screw drivers and single-bladed screw drivers should be enough. (EIKI screw driver kits, P/N 5615 are available.) A Molex extractor tool is most useful when replacing the pins of Nylon connectors to the transformer or motor.

B. Special Tools:

EIKI "N" series have been designed so that no special tools are required to service the projector. However, a common claw protrusion gauge (Tool No. 320-01T) is most helpful for accurately setting the claw protrusion. Standard 16mm film may be used as a thickness gauge where necessary. (Most film is about 0.15mm or .005" thick).

Tool No. 320-01T

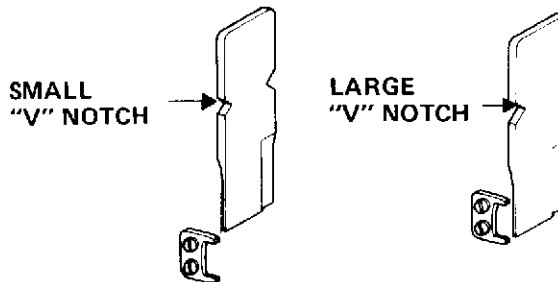
Cam Claw Protrusion Tool  
(see sec. 4-1-D)C. Test Equipment:

A limited amount of test equipment is required for routine maintenance and modular replacement. However, when servicing the individual modules such as the amplifier, the following equipment and test films would be essential:

- a. Vom (Voltage/Ohm meter)
- b. Oscilloscope
- c. Audio AC VTVM
- d. Wow & Flutter Meter
- e. 400Hz SMPTE Test Film
- f. 3150Hz Wow & Flutter SMPTE Test Film
- g. Multi Frequency SMPTE Test Film
- h. 7000Hz Sound Focus SMPTE Test Film
- i. 7000Hz Mag. Azimuth SMPTE Test Film
- j. Buzz Track SMPTE Test Film.
- k. Audio Oscillator

## 2-3: LUBRICANTS & LUBRICATION CHARTS

Apply a few drops after every 500 operating hours. The items marked with \* would require more frequent lubrication.

**CAUTION: DO NOT OVERLUBRICATE.**

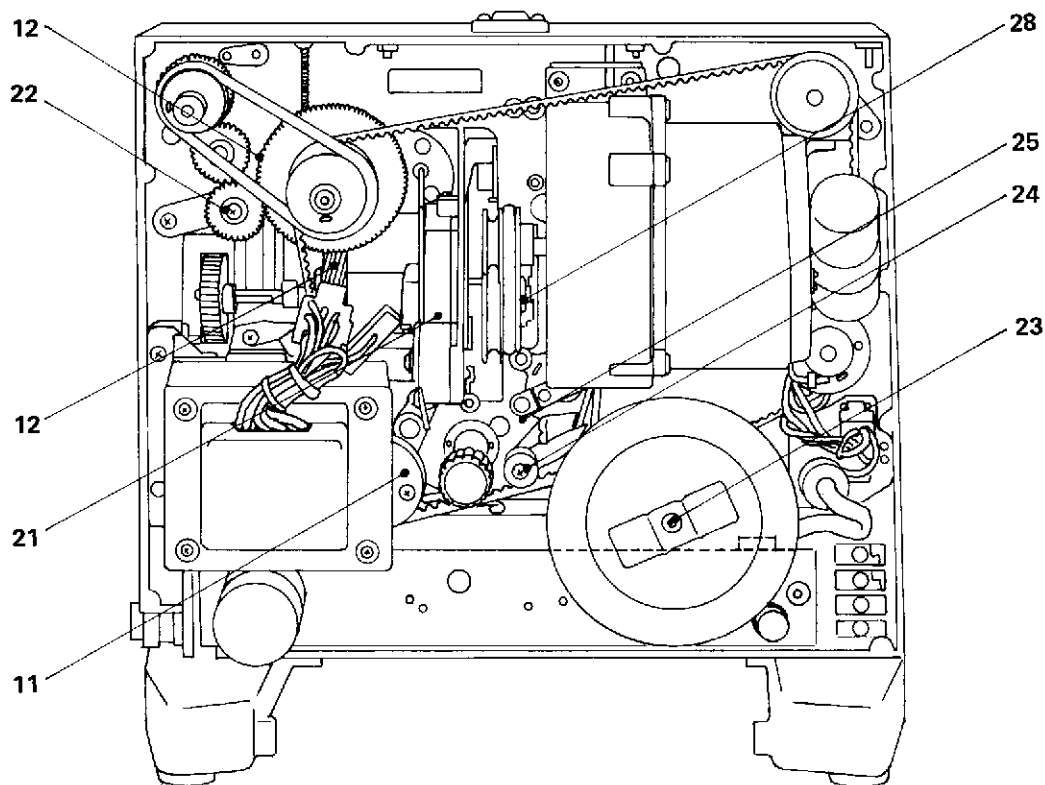

Fig. #1

EM #	DESCRIPTION	SUGGESTED EIKI LUBRICANT	EIKI PART #	ITEM #	DESCRIPTION	SUGGESTED EIKI LUBRICANT	EIKI PART #
#1	Sprocket Hub	Petroleum Oil	5631	15.	*Take-Up Pulley Cork Liner	Silicone Grease	5625
#2	Sprocket Hub	Petroleum Oil	5631	16.	Loop Setter Shaft	Petroleum Oil	5631
	Duracon Guide Rollers	Silicone Oil #100	5629	17.	#3 Film Guide Pivot Pin	Silicone Oil #100	5629
	Duracon Guide Rollers	Silicone Oil #100	5629	18.	Tension Guide Roller & Bracket Pin	Silicone Oil #100	5629
*	Rubber Pinch Roller	Molybdenum Disulfide Grease	5628	19.	*Take-Up Pulley & Shaft	Molybdenum Disulfide Grease	5628
	Self-Thread Lever	Petroleum Oil	5631	20.	*Supply Arm Spindle Shaft	Petroleum Oil	5631
	Rubber Pinch Roller Pivot Shaft	Petroleum Oil	5631	21.	Cam Tank	Molybdenum Disulfide Grease	5628
	Rewind Lever Shaft	Petroleum Oil	5631	21-A	Cam Tank Felt	Molybdenum Disulfide Oil, or Grease	5632 (5628)
	Dampening Roller Pivot Shaft	Petroleum Oil	5631	22.	Rewind Gears' Shaft	Silicone Oil #100	5629
	Tension Gear Arm Pivot Pin	Petroleum Oil	5631	23.	Flywheel Hole	Petroleum Oil	5631
	Tension Gear Shaft	Silicone Oil #100	5629	24.	Loop Safety Roller	Silicone Oil #100	5629
* #1	Sprocket Gear & Worm Gear	Petroleum Oil	5631	25.	Main Interlocking Bracket	Silicone Grease	5625
* Reverse	Rubber Roller Shaft	Petroleum Oil	5631	26.	Reel Guide Bracket Hole	Petroleum Oil	5631
	Sound Drum Ball Bearings	(Factory sealed)	OB-608Z				

**(LUBRICANTS & LUBRICATION CHARTS)**

ITEM #	DESCRIPTION	SUGGESTED EIKI LUBRICANT PART #	ITEM #	DESCRIPTION	SUGGESTED EIKI LUBRICANT PART #
27.	Reel Guide Wire	Petroleum 5631	31.	Function Switch Cam Bracket	Molybdenum Disulfide Grease 5628
28.	Anchorage Fulcrum Pin	Oil	32.	Function Switch Shaft	Molybdenum Disulfide Grease 5628
29.	Shutter Pulley Bushing	Molybdenum Disulfide Grease 5628	33.	Loop Safety Roller Arm Pin	Silicon Grease 5625
30.	Cam Tank Fulcrum Pin	Petroleum Oil (Factory sealed)	34.	Clutch Cover Pulley Bushing	Petroleum Oil 5631
		OB-608Z			
		OB-608ZZ			
		OB-6200ZZ			
		OB-626			

**FILM PATH**

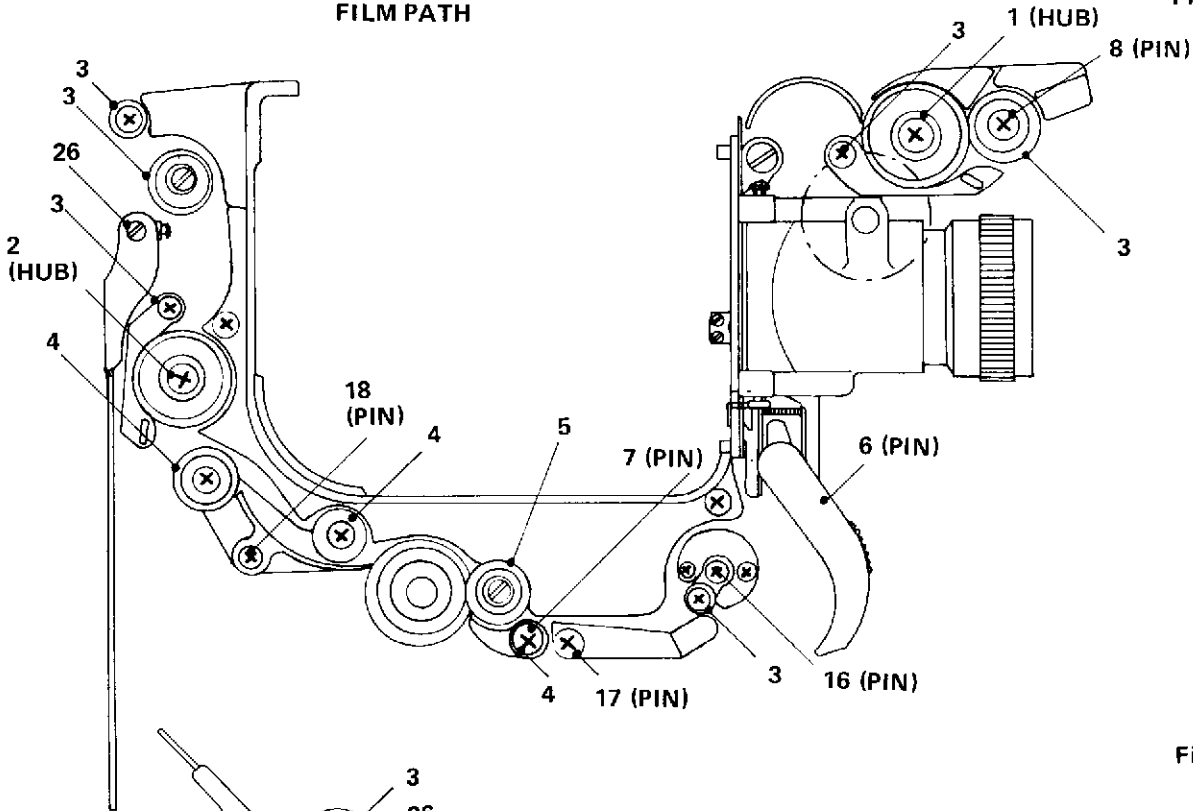

**SELF-THREADING MECHANISM (Main Interlocking Bracket)**

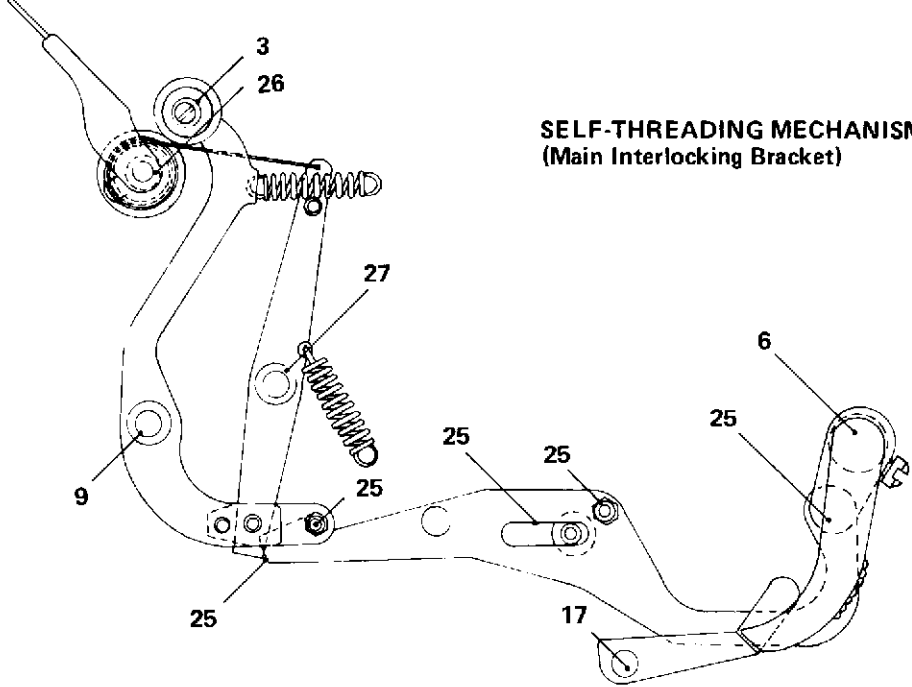
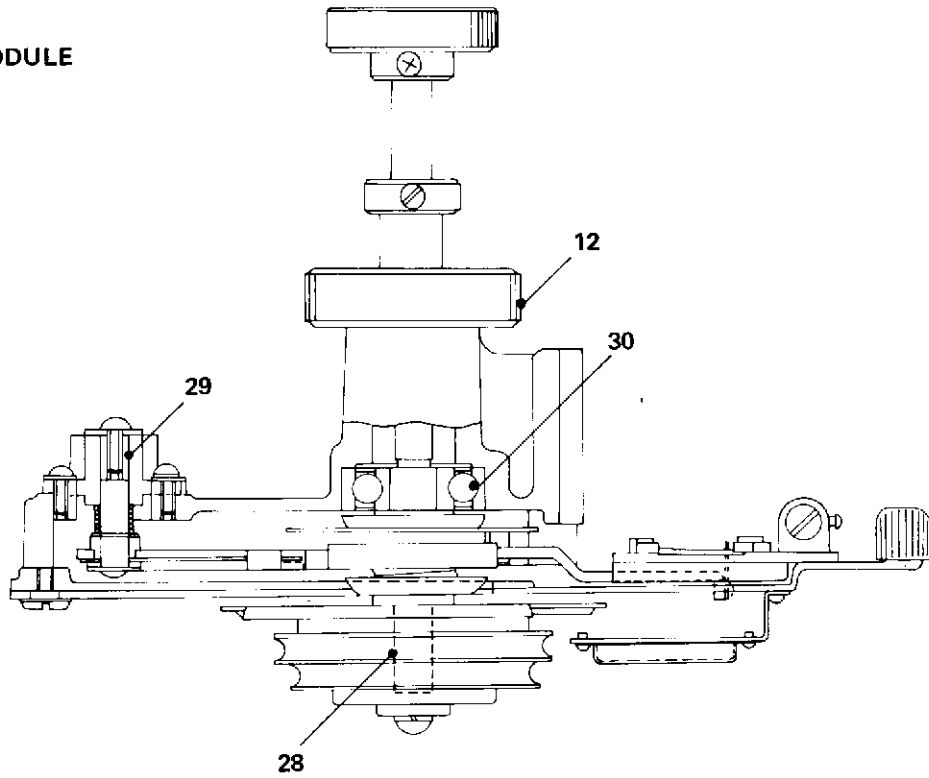

Fig. #4

CAM TANK MODULE



CAM TANK MODULE & FILM GATE

Fig. #5

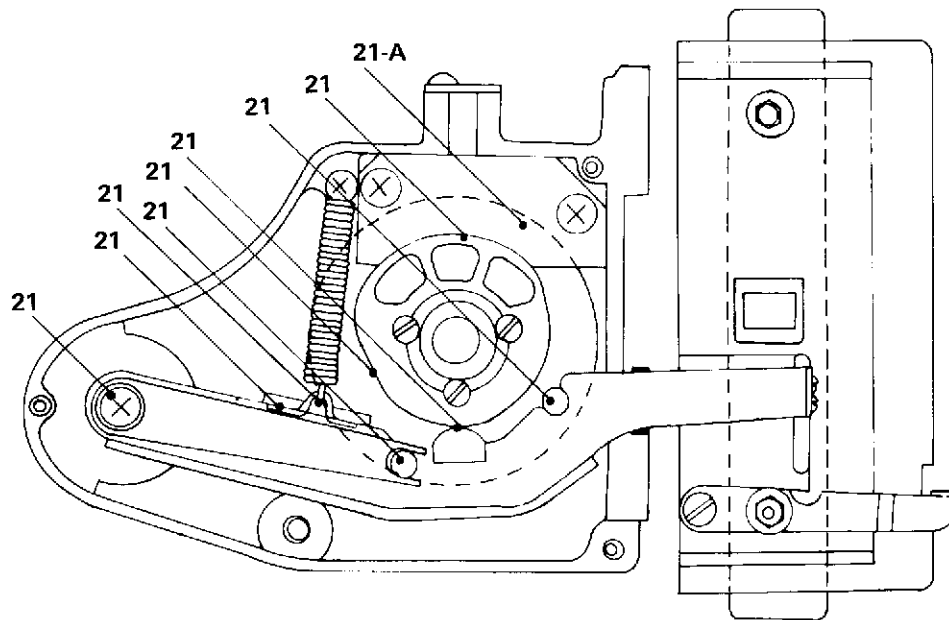

**(LUBRICANTS & LUBRICATION CHARTS)**

"N" Series

**#1 SPROCKET GEAR & HUB,  
CLUTCH COVER PULLEY**

**Fig. #6**

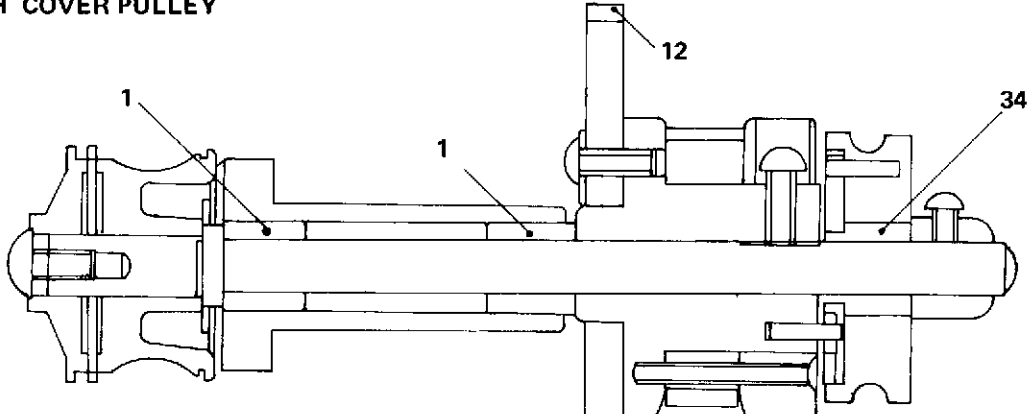

**SOUND DRUM, HUB,  
& FLYWHEEL**

**Fig. #7**

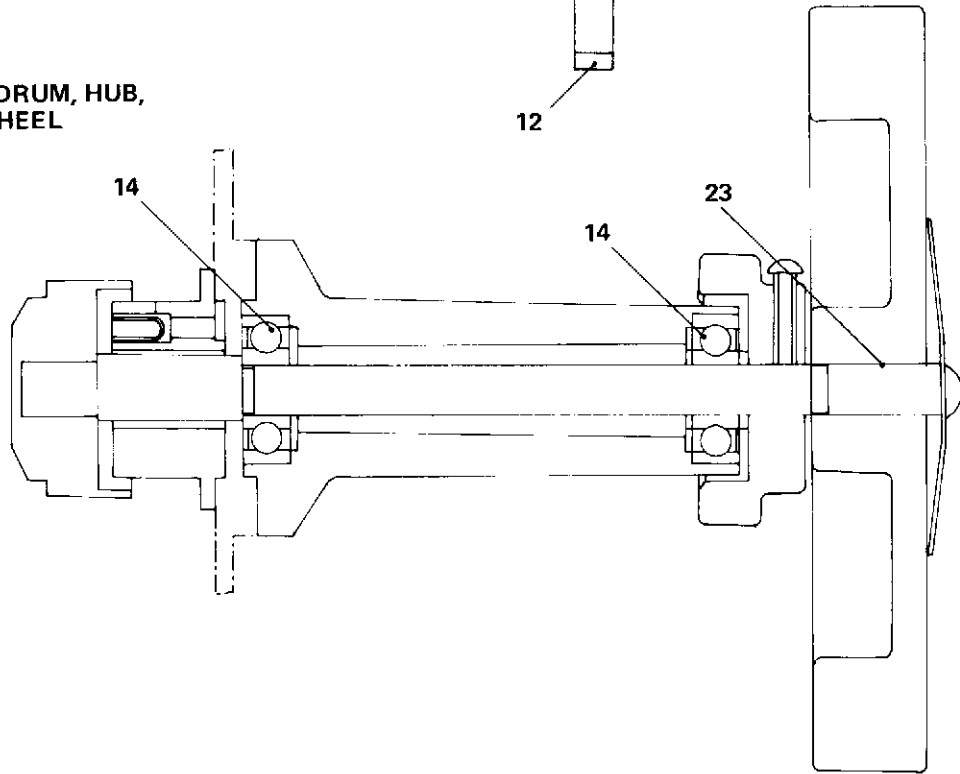

**TAKE-UP PULLEY & SHAFT**

**Fig. #8**

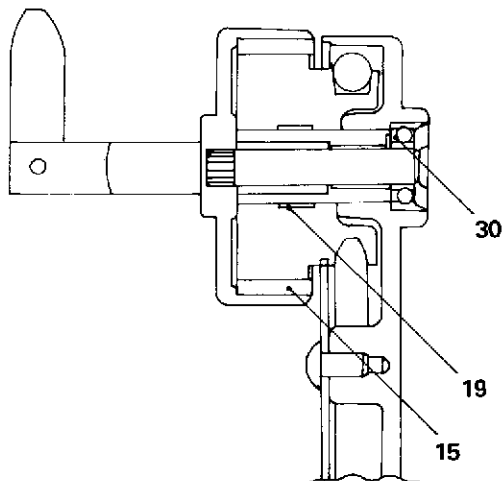

**LOOP SETTER**

**Fig. #9**

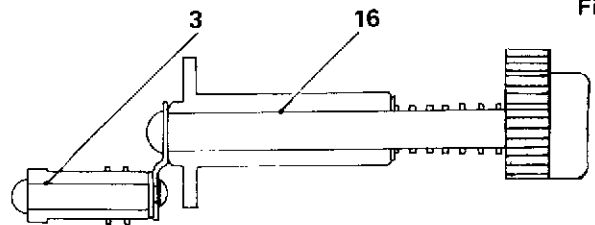

**(LUBRICANTS & LUBRICATION CHARTS)**

**"N" Series**

**Fig. #10**

**REWIND GEARS & CONTROL LEVER**

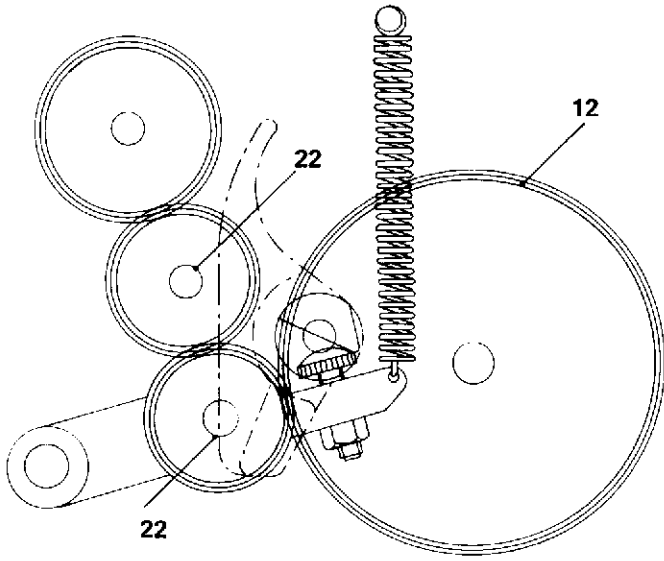

**Fig. #11**

**TAKE-UP ARM DRIVE PULLEY**

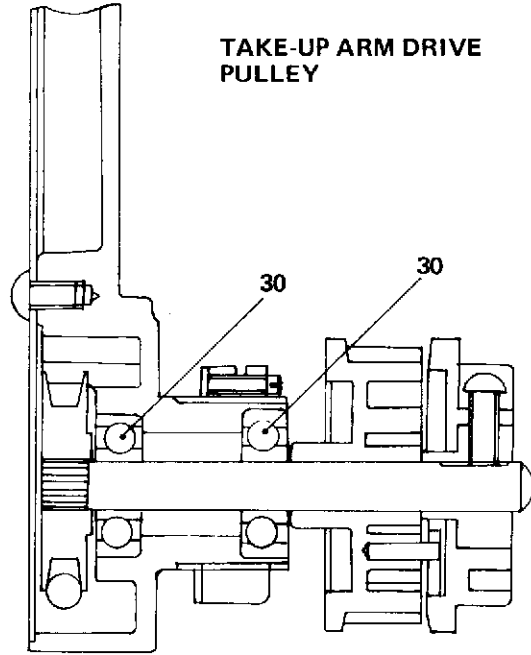

**SUPPLY ARM DRIVE PULLEY**

**Fig. #12**

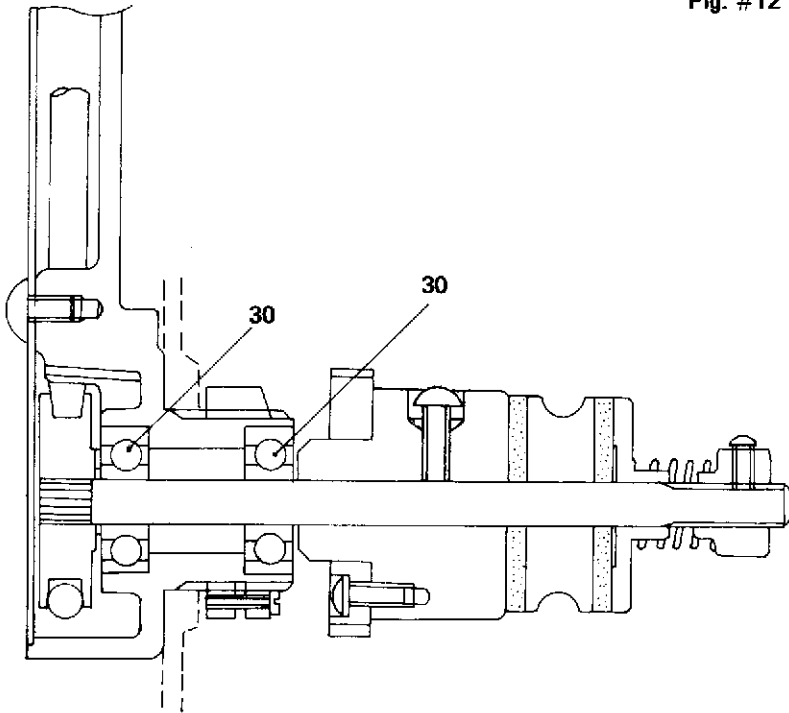

**TENSION GEAR**

**Fig. #13**

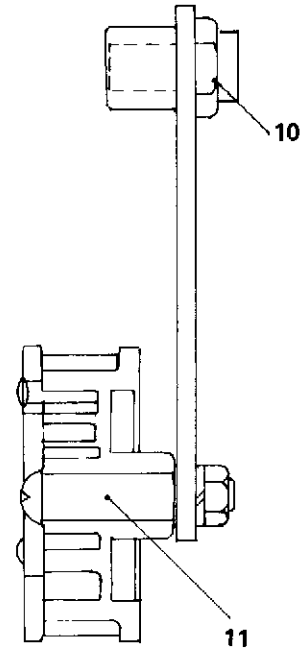

**(LUBRICANTS & LUBRICATION CHARTS)**

**"N" Series**

**SUPPLY ARM SPINDLE  
SHAFT**

**Fig. #14**

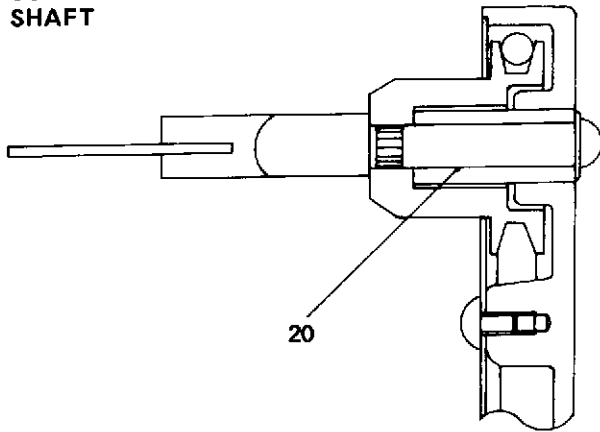

**REVERSE RUBBER ROLLER  
PIN**

**Fig. #15**

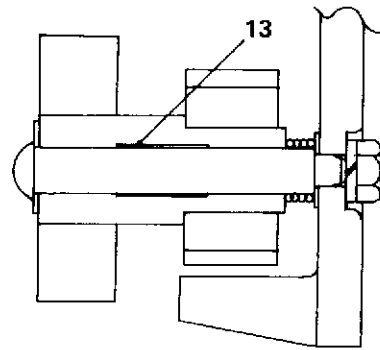

**RUBBER PINCH ROLLER**

**Fig. #16**

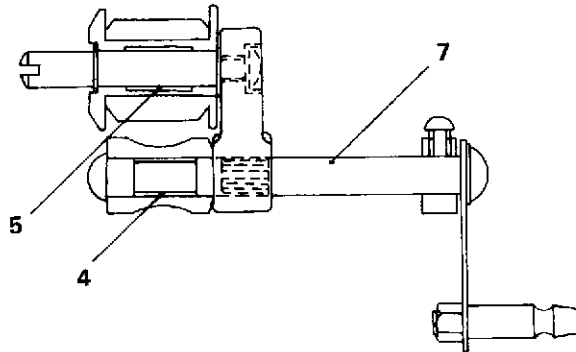

**FUNCTION ROTARY SWITCH**

**Fig. #17**

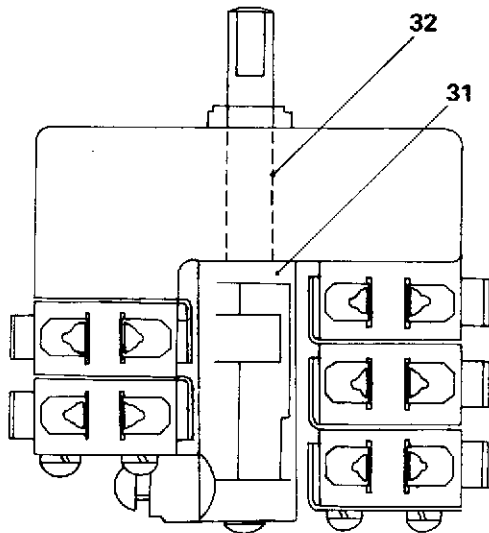

**LOOP SAFETY  
ROLLER ARM**

**Fig. #18**

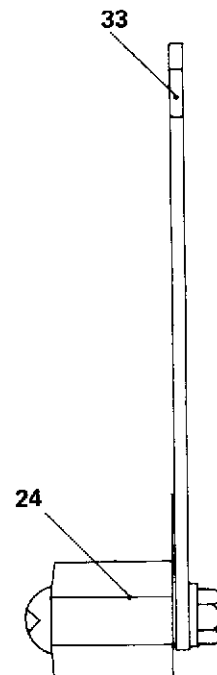



2-4: TROUBLE SHOOTING HINTS

- A. There are four basic steps to trouble shooting this projector:
- a. Analyze the symptom
  - b. Localize the trouble to a functional system or module
  - c. Replace or repair that system or module
    - a. Isolate the trouble within the module
    - b. Locate and repair the specific trouble
- B. Checking Semiconductors With A VOM:
- a. Set the ohms scale to R x 10
  - b. The forward resistance should be low
  - c. The reverse resistance should be high

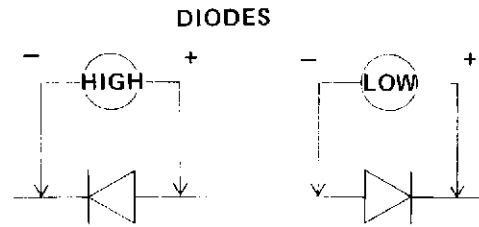

**NOTE:** Forward and reverse resistance LOW & HIGH is only a suggested quick and easy check of components out of circuit. This test is only for shorted and open junction test. A VOM will not test the quality of a semi-conductor accurately.

TRANSISTOR NPN TYPE (2SC, 2SD) Fig. #19

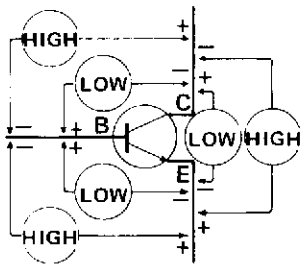

TRANSISTOR PNP TYPE (2SA, 2SB) Fig. #20

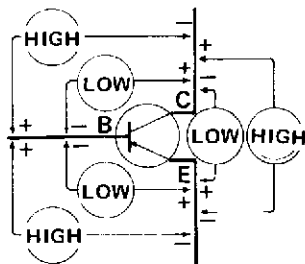

- C. IC's are best checked by checking the signal input and output condition. This can be done by inserting a low level audio tone into the MIC jack and the signal path from the input of IC-1 through IC-2 and to IC-3.
- D. Amplifier test cables can be easily made from locally available parts. A nine pin miniature tube socket and male plug can be wired as an extension power cable, allowing the amplifier to be operated away from the projector. The solar cell and exciter lamp connection can also be extended if so desired.

Typical Amplifier Test Set-Up

Fig. #22

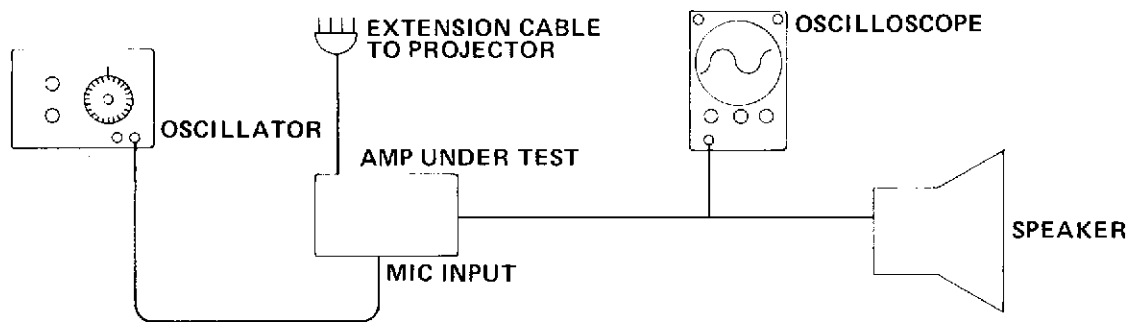

# 314-3: MODULE REMOVAL AND INSTALLATION PROCEDURE

"N" Series  
(3-2)

Fig. #23

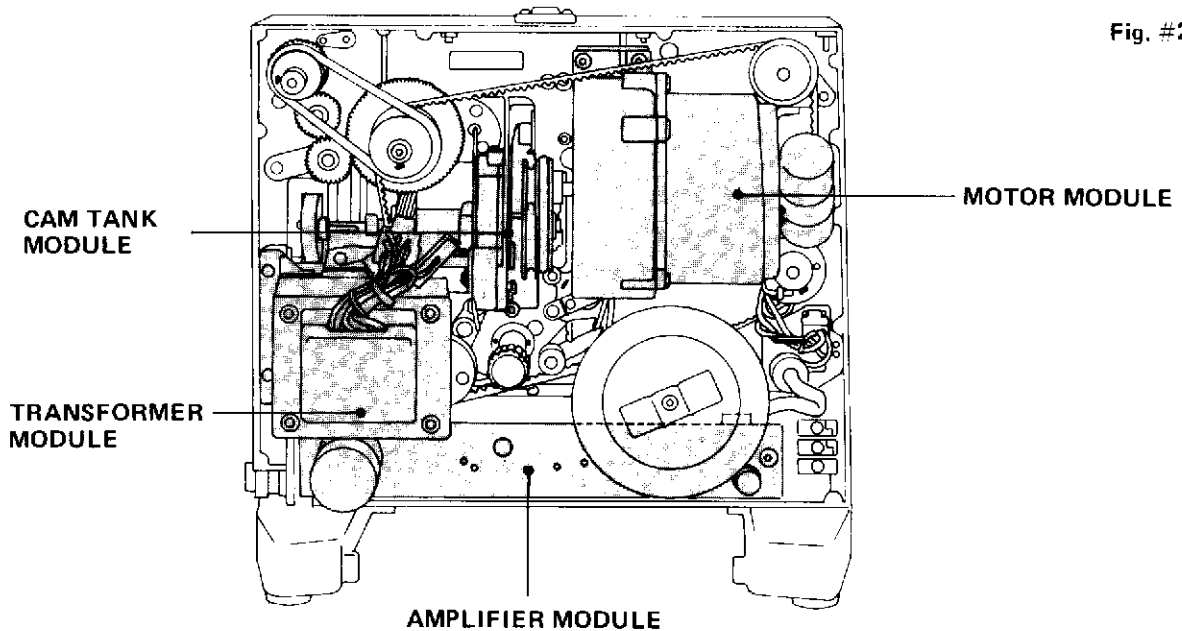

## 3-1: CAM TANK MODULE

1. Unplug the projector and open the rear cover.
2. Remove the 3 transformer mounting screws and unplug the transformer. (See Sec 3-4)
3. Remove the motor belt.
4. Remove the main driving belt by releasing the tension gear.
5. Retract the claw by turning the inching knob.
6. Open the lamphouse and remove the lamp and holder assembly by unscrewing the knurled nut.
7. Unscrew the two cam tank mounting screws.
8. Remove the cam tank slowly and carefully. Care should be taken to avoid damaging the claw by striking it against the main casting.
9. Re-installation can be done by the reverse procedure. Care should be taken that the cam tank worm gear and main drive fiber gear do not bind. A small amount of gear lash is required to prevent abnormal wear.
10. To check the timing and claw adjustments, refer to Sec. 5-1 and 6-3.

## 3-2: AMPLIFIER MODULE

1. Remove the flywheel.
2. Unplug the rear cover speaker cord.
3. Remove the volume, bass and treble knobs.  
**NOTE:** on magnetic models remove the mag/opt knob.
4. Unplug the MT 9 pin plug.
5. Unplug the solar cell and magnetic lead miniature plug.
6. Remove the two phillips screws, one at each end of the amplifier.
7. The amplifier can now be removed by sliding out.
8. To re-install, reverse the procedure above. Be sure that the indicator on the controls lines up and all the connectors are secured.

Fig. #25

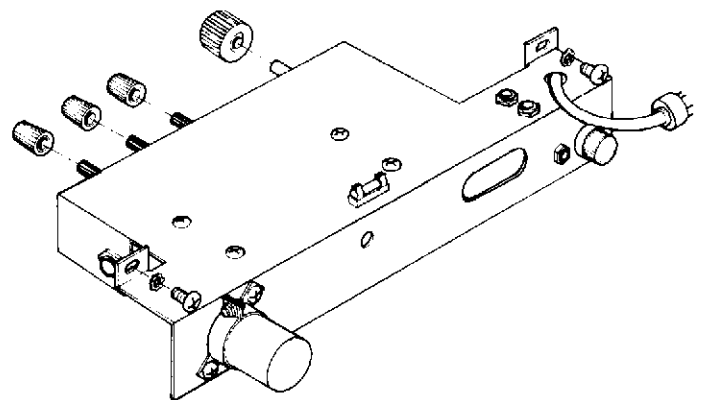
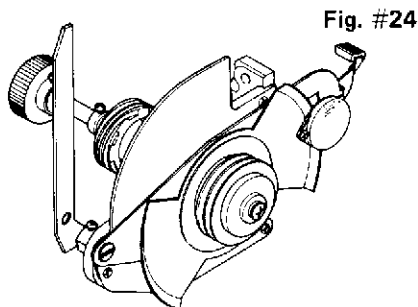
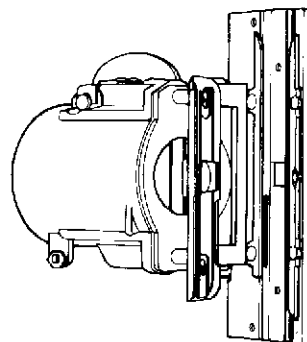

Fig. #28

### 3-3: MOTOR MODULE

1. Remove motor belt.
2. Disconnect motor nylon connector(s).
3. Unscrew 3 screws.
4. Remove motor module.
5. Motor modules are exchanged less pulley.
6. To re-install, reverse the above procedures.
7. Motors with plastic fan housings use the ground strap. NST after S/N 10484, and NT after S/N 18550, with metal fan housing (320-12141), the ground strap has been omitted.



**GROUND STRAP (FOR PLASTIC FAN HOUSING OF EARLY PRODUCTION)**

Fig. #26

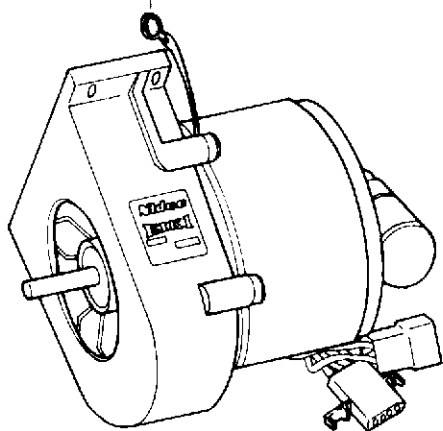
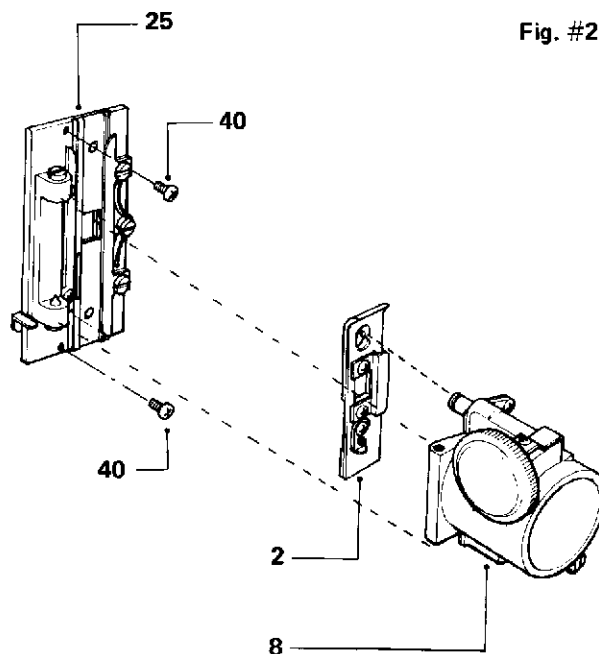

Fig. #29



### 3-4: TRANSFORMER MODULE

1. Unplug nylon connectors.
2. Unscrew 3 screws.
3. To re-install, reverse the above procedures.  
(Care should be taken that the wires are routed away from any moving parts of the projector).

Fig. #27

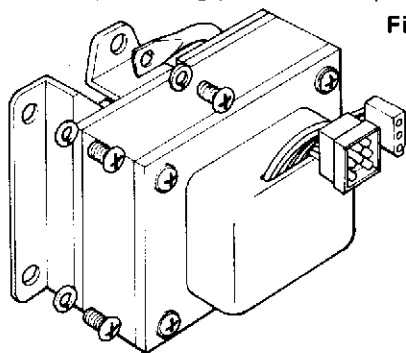

3. To re-install the film gate assembly, follow the reverse procedure. It is also necessary to check and adjust the claw travel in the aperture plate assembly. (See section 4-2 claw position and framing).

### 3-5: LENS AND GATE MODULE

1. Swing open the gate and remove the lens. (Anti-theft screw on U.S.A. models).
2. Remove the two phillips screws (40) securing the film gate assembly to the main casting. (Fig. #29)

## 314-4: MODULE REPAIR AND ADJUSTMENTS

### 4-1: CAM TANK MODULE

#### A. Specifications

Revolution

24 FPS. 1440 RPM

18 FPS. 1080 RPM

Cam Claw Protrusion MIN. 1.0mm – MAX. 1.2mm  
(.040" to .045")

Claw Pitch 7.64 – 7.67mm

\* Tension of Claw Lever Spring 1.2 – 1.25kg.  
Spring 312-11161

**NOTE:** Tension of Claw Lever Spring is measured with a tension scale pulling on Cam Claw and the Claw Lever Spring stretched to maximum.

#### B. Disassembly of Cam Tank (Fig. #30 & 31)

1. Set the still picture clutch to the still position with the shutter pulley (50) rotating freely.
2. Unscrew (53) at the end of the cam shaft and shutter pulley (50).
3. Remove shutter pulley (50) and the plate washer (51). Care should be taken not to loose the slim washer (54) behind the plate washer. The slim washer is selected where necessary to provide the correct clearance between the shutter pulley (50) and the shutter blade and hub (46).

4. While holding the shutter blade (46) slowly raise the still picture clutch, releasing the tension of the clutch spring (12) and shutter blade with hub.
5. Remove the shutter blade and hub assembly.
6. Position the still picture clutch where it exposes all three cam tank cover screws (45). Remove the screws and cover plate assembly.
7. The curved plate spring (24) fits over fulcrum control pin. Unscrew the screw (22) and remove curved plate spring.
8. Unhook the claw lever spring (36), and remove claw lever assy. (28)
9. To remove cam (10) and cam plate (9), unscrew the three set screws (11).
10. To remove cam shaft assy. (4), remove inching knob (8) and worm gear (7).
11. To replace the cam tank bearings, the inner bearing is pressed on the cam tank shaft and is replaced as part of the cam shaft with bearing assy.
12. Clean all the old dried molybdenum grease from the cam tank.

Fig. #30

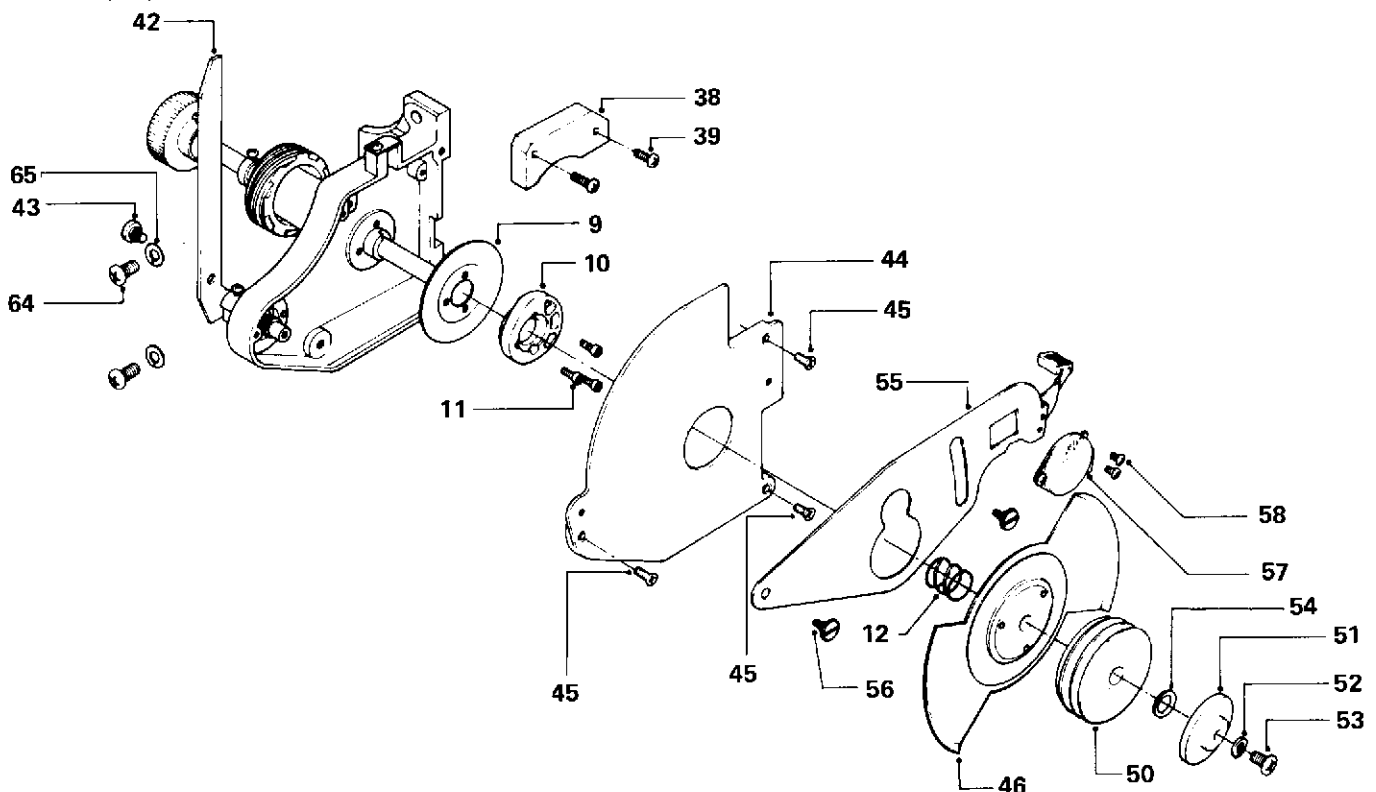

Fig. #31

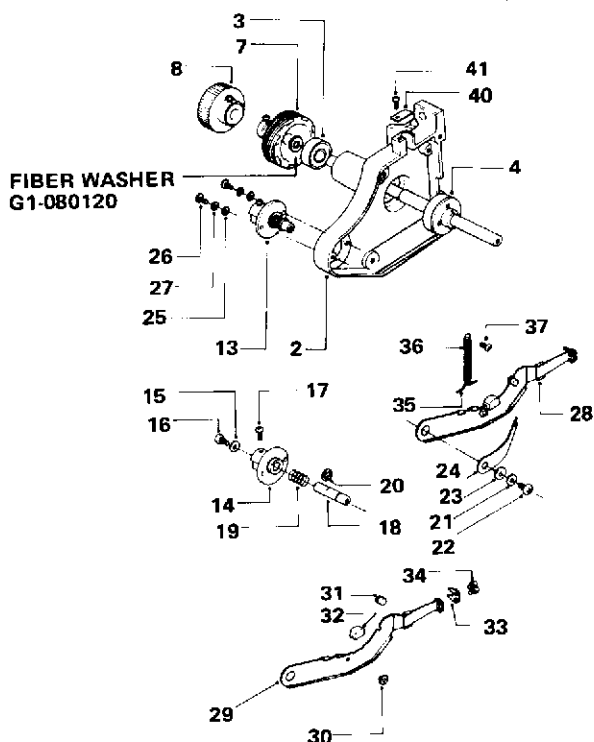
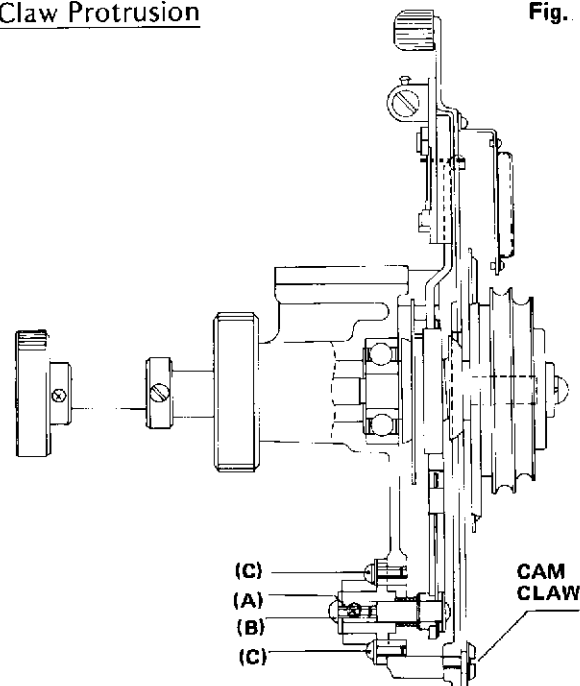

Fig. #32



D. Adjustments  
1. Claw Protrusion

C. Reassembly of Cam Tank By Reversing The Above Procedure

1. Make sure curved plate spring (24) is not jammed between the end of fulcrum pin (18) and washer (23).
2. The cam shaft should have no end play.
3. Worm gear (7) is mounted without clearance between the cam tank bearing.
4. No end play is allowed for the ball bearings on the cam shaft.
5. When overhauling the cam tank, it is suggested that the felt oil pad be replaced.
6. Re-lubricate the cam area with a small amount of molybdenum disulfide grease and moisten the felt with a few drops of molybdenum oil.
7. When mounting the shutter blade and hub assembly, the hub must line up with the mating hub in the cam tank.

NOTE: In the event the shutter has been removed from the hub, See Sec. 320-4-1-F Changing Shutter Blades.

- a. Claw protrusion can be adjusted by the screw (B) on the fulcrum collar. As the sliding pin (31) wears, the protrusion will increase requiring the adjustment of the protrusion.

Fig. #33

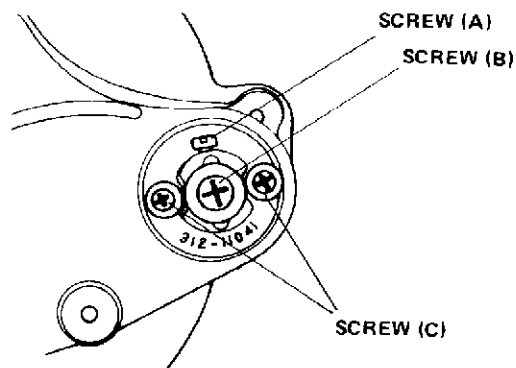

- b. Loosen set screw (A) by 1/8 of turn as indicated in Fig. #32 & 33.
- c. Turn screw (B). Loosening screw (B) (counter-clockwise) increases the claw protrusion. Tightening the screw (B) (clockwise) decreases the claw protrusion.

d. Checking claw protrusion using Tool No. 320-01T (fig. #34)

- (1) Open lens holder and gate assy.
- (2) Attach the tool between the inner guide rail and the outer guide rail.
- (3) With the small "V" notch toward the outer guide rail, the claw should just contact the tool.
- (4) With the large "V" notch toward the outer guide rail, the claw should move freely without contacting the tool.

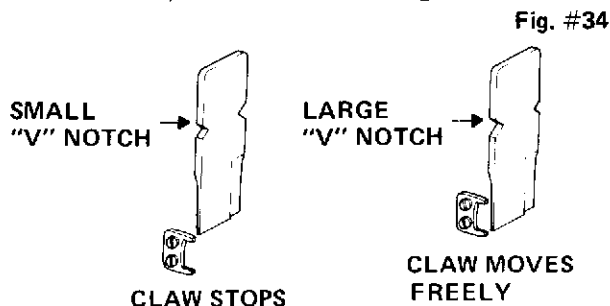

e. When using another type of claw protrusion gauge of similar specifications as (320-4-1), disregard items 2, 3, 4 and follow the instructions associated with that gauge.

2. Claw Position And Framing Adjustments:

a. If the claw does not enter the center of the film perforations, or if the framing adjustment is insufficient, the claw position should be adjusted. This adjustment can be either horizontal or vertical. To adjust the fulcrum assy. slightly loosen the two screws (C) shown in Fig. #32 & 33.

(1) Checking the Framing Adjustment: This is best accomplished with the projector running, showing a shop test film. With the framing control lever in the up position, the frame bar of the film should appear as in (Fig. #35) and in the down position the frame bar should appear as in (Fig. #36).

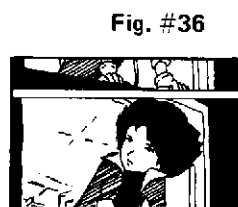
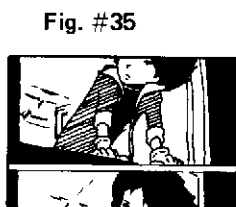

(2) If the conditions in step 1 are not correct, adjust the vertical or up and down position of the fulcrum assy. (Fig. #32 & 33) by slightly loosening screws (C) on the fulcrum assembly.

Only a very small movement is required to effect the framing position.

NOTE: If framing range as indicated cannot be reached, check for a worn cam follower (32 of Fig. #31)

(3) Checking Position For Correct Alignment With The Sprocket Holes:

To view the claw position in the sprocket holes, thread a strip of good film. Remove the film shoe and bracket assy. With a standard 50mm (2") lens installed, look through the lens. Focus and rotate the inching knob while observing the claw position in the film sprocket holes. (Do not turn on the lamp).

(4) Fig. #37 indicates the correct position of the claw just before the start of the pull-down. Fig. #38 indicates the position after completion of the pull down.

(5) To adjust the claw position, move the fulcrum assy. horizontal and slightly vertical until the distances a, b, c, d are equal as indicated in Fig. #37 & 38. Upon completion of the position adjustment, tighten the fulcrum assy. screws and re-check the framing range with the projector running.

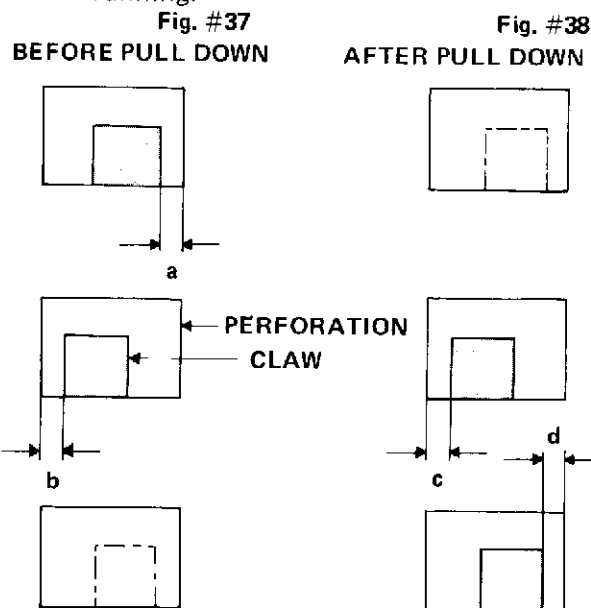

### E. Replacing The Claw

When replacing a worn or defective claw, it is important to mount the claw correctly before securing the mounting screws. Incorrect claw mounting may result in excessive film gate noise or unsteady picture.

#### 1. Correct Claw Pitch

The International dimensions of the 16mm film Fig. #39

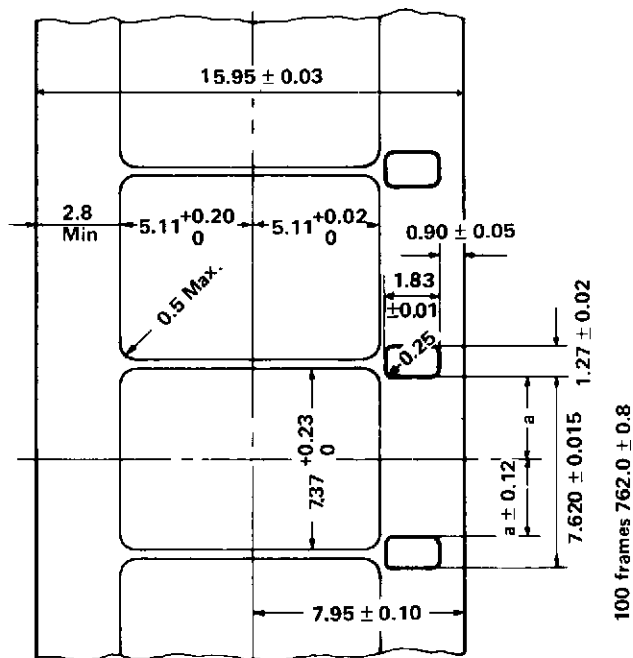

- The International dimensions of the 16mm film are shown in Fig. #39. Claw pitch is set at 7.64 – 7.67mm. A pitch less than 7.64mm will cause the claw to engage the film between perforations possibly causing film damage or unsteady pictures.
- A pitch more than 7.67mm will cause excessive gate noise. Typical film perforation should have a pitch of 7.605 – 7.635mm, but older films may have a smaller pitch due to shrinkage.
- The claw as shown in (Fig. #40) has a 5 degree angle at the top tooth, and should the claw pitch become larger than the pitch of the perforations, this would help prevent any film damage.

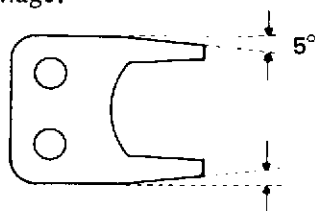
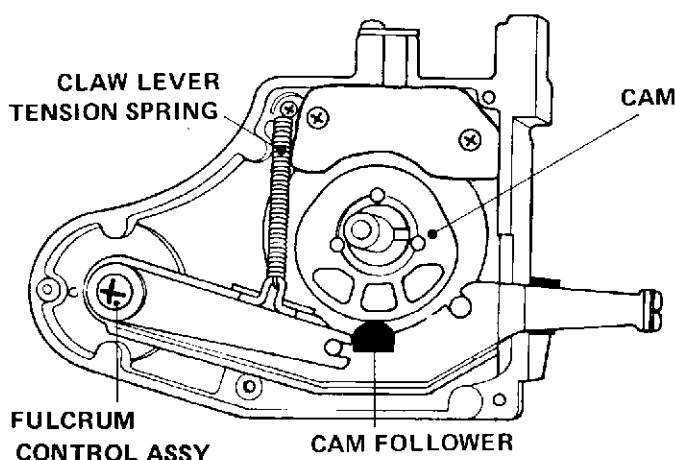

Fig. #40

#### 2. Adjusting The Claw Pitch

- Moving the fulcrum control assy: The fulcrum control assy (Fig. #41) horizontally adjusts the contact point between the cam follower and the cam which in turn effects the claw pitch. Moving the fulcrum control assy. to the left decreases the pitch and moving it to the right increases the pitch.

Fig. #41



- The fulcrum control assy. should only be moved slightly. Too much adjustment will cause the claw to hit the sides of the film perforations causing film jitter.
- Correct claw angle is shown in Fig. #42-A. Under some circumstances a bent claw lever as shown in Fig. #42-B and 42-C may have to be corrected by straightening out the claw.

Fig. #42

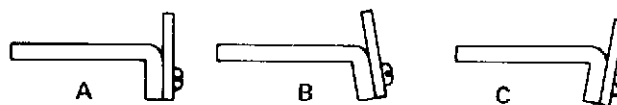

#### 3. Claw Lever Tension (See Fig. #41)

The claw lever tension force should be from 1.2 to 1.25kg when the spring is stretched to the maximum travel of the claw lever arm. If the tension is too weak, the cam follower may float off the cam surface causing excessive gate noise and an unsteady picture. On the other hand, if the spring is too strong the cam follower may wear out prematurely or cause a slight hesitation of the claw lever when the projector is initially started. To obtain the correct tension it may be necessary to replace the spring. A slight adjustment can be made by stretching the spring if necessary.

F. Changing Shutter Blades

Fig. #43

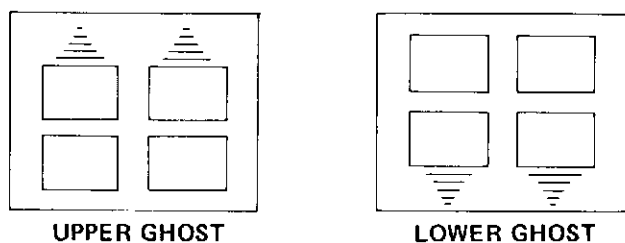

Two, three and five bladed shutters can be mounted on the shutter pulley. The mounting holes used to secure the blades to the pulley allow a small adjustment for shutter blade timings. Incorrect shutter timing results in what is commonly called "travel ghost". The adjustment is accomplished using the SMPTE test film and adjusting the blade position for minimum upper or lower image movement as shown in (Fig. #43). Since the adjusting screws are only accessible with the cam tank removed, this becomes a trial and error adjustment. However, the skilled technicians can accomplish this in one or two adjustments.

When mounting the 2 blade shutter, the missing semi circle on the hub must be positioned toward one of the blades. The curved edge of the blade faces away from the cam tank (See Fig. #44, 45).

Fig. #44

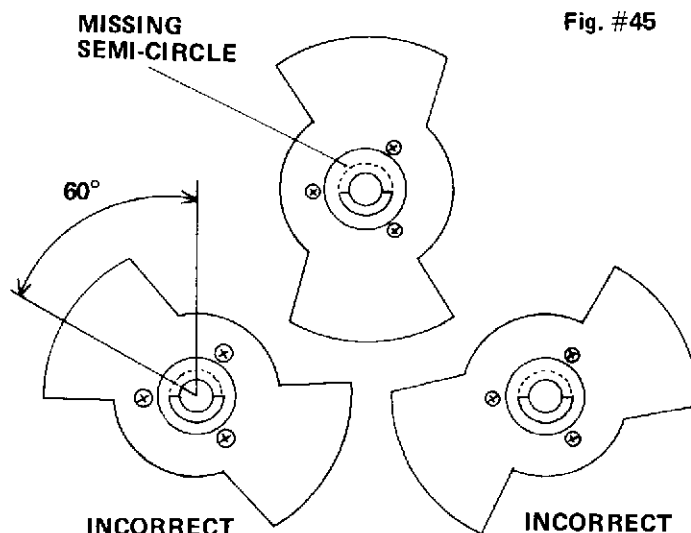
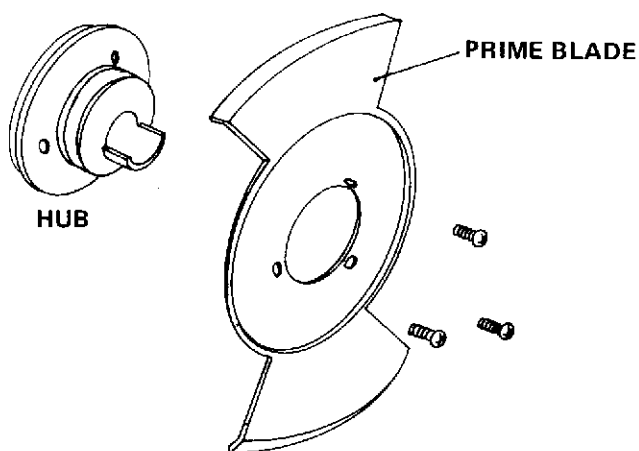

NOTE: 3 BLADED SHUTTERS WILL AUTOMATICALLY LINE UP CORRECTLY.



### G. Still Picture Clutch

The still picture clutch consists of the shutter pulley (50), the shutter blade and hub (46) and the still picture clutch lever (55) and tension spring (12). The friction between the shutter blade hub's coned surface and the coned surface of the shutter pulley is maintained by the tension spring (12) when the still picture clutch is in the up position, driving the cam tank and the rest of the projector mechanism. In the down position the still picture clutch lever releases the spring tension, slightly separating the shutter blade hub and the shutter pulley. To adjust the still position clearance, spacer (54) may be added or deleted, as necessary. Lubricate the bushing with a small amount of molybdenum disulfide grease. In the still position the heat filter (57) allows a single frame to be shown without burning the film, however, the projector is not designed to operate in this position for extended periods of time. Long still operations will cause premature wear to the shutter pulley bushing and cam tank shaft.

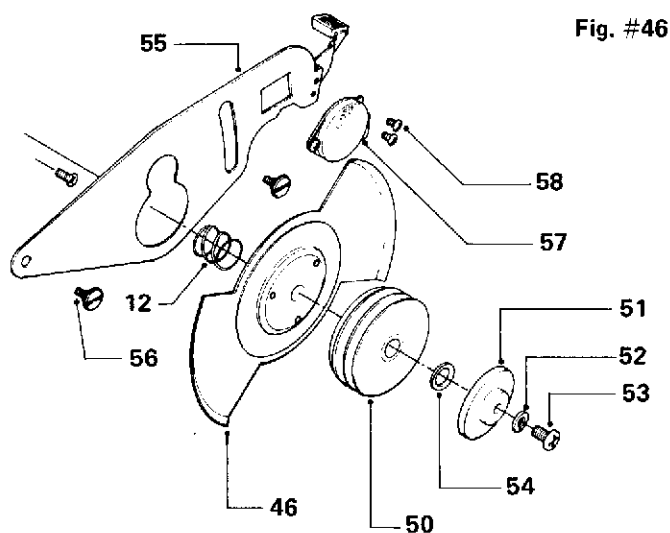

## 4-2: AMPLIFIER MODULE

Refer to the amplifier circuit diagram:

### A. Specifications

1. Solid state: 3 IC's 7 transistors (9 transistors for -3 type)
2. Output power: 20 watts RMS 8 ohm load
3. Distortion: Less than 4% at 400Hz  
(measured with SMPTE 400Hz Signal Level Test Film)  
Less than 1% at 1KHz  
(measured with SMPTE Multi-Frequency Test Film)
4. Wow & Flutter: Less than 0.2% WRMS.
5. Frequency response:  
Optical 50Hz – 7000Hz ± 4db  
Magnetic 50Hz – 10000Hz ± 4db  
Magnetic Recording Range 50Hz – 10000Hz
6. S/N ratio of the amp: 60db
7. Mic input impedance: 600 ohm and up.
8. Mic input level: 10mv max (high or low impedance for -2 type and high impedance only for -3 type.)
9. Phono input level: 50mv (high impedance)
10. Speaker Jacks: 8 ohm

### B. Amplifier Power Supply Circuit (SEE FIG. 47)

40 volts AC power to the amplifier is supplied from the transformer secondary windings through pins #1 & 2 of the 9 pin socket (MT-9).

(NOTE: NT projectors after S/N 26136 and NST after S/N 10674 are supplied with 36V AC standard and 40V AC optional. See Sec. 4-4 TRANSFORMER MODULE)

Dual diodes S1 and S2 form a bridge rectifier, filtered by capacitor C-44, providing the amplifier approximately 56V DC (or 50V DC). The 8V AC transformer secondary winding supplies AC exciter lamp voltage through pins #4 and #5 of the 9 pin socket. Dual diodes S3 and S4 form a bridge rectifier which is filtered by capacitor C14. C15 and C16 are ripple filters regulating the base input voltage to TR-1's base. R-32 is a current sense resistor serving as feedback to the base of TR-2 through R-29.

TR-2 is a protector for this regulating circuit. TR-1 is the DC regulator for the approximately 3.5 volts to the exciter lamp, routed through pins #8-9 of the 9 pin socket.

In -2 type magnetic playback the exciter lamp voltage is switched off, while in -3 type magnetic playback this switch is not provided.

### C. Audio Amplifier Circuit

The input signal from the solar cell or magnetic head is accomplished through respective miniature jacks in the top of the amplifier chassis. (See Fig. #48)

Fig. #47

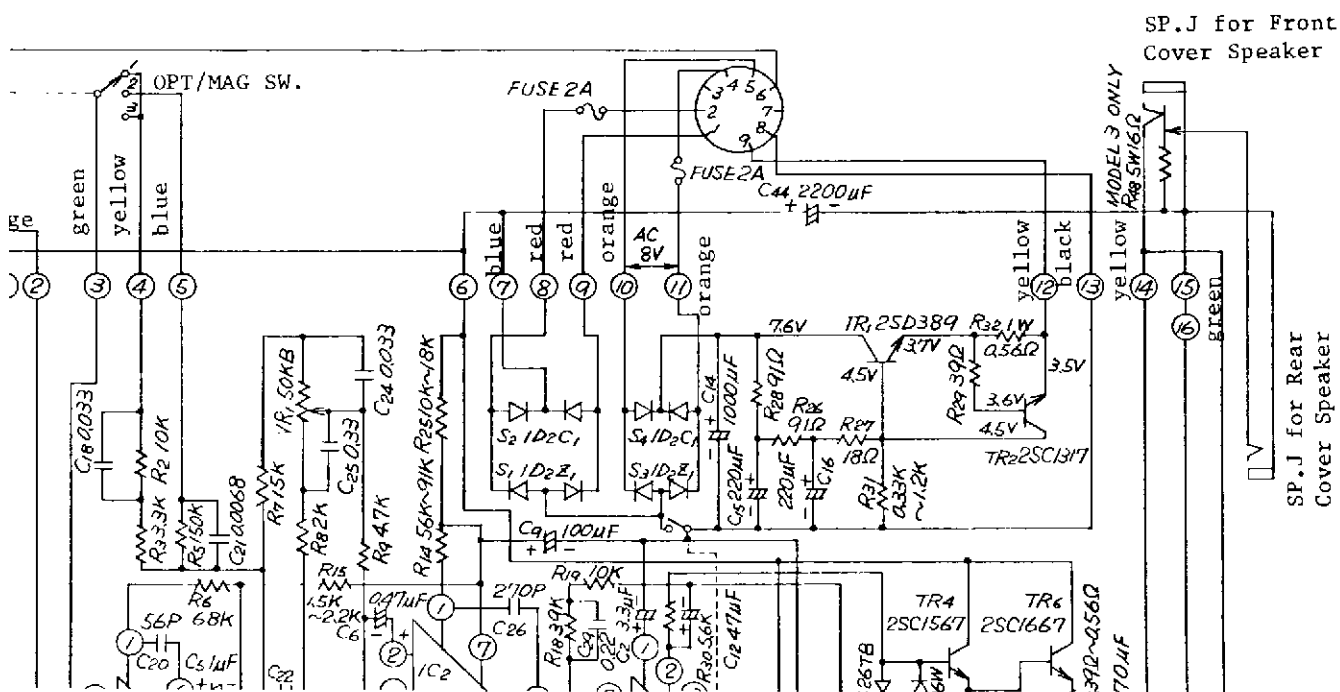

R46 presents a 10K impedance load to the solar cell in optical playback. C42, R50, R54 and C48 for the input equalization network. The signal is coupled to IC1 (AN360) through capacitor C1. Feedback to IC1 is accomplished through a selectable network consisting of C18, R2, R3, R5 and C21. Position 1 and 3 of optical/magnetic selector switch provides a linear response of IC1. Position 2 switches in the magnetic playback equalization required. Bass control VR-1, R8, C25, C24 and R9 form a low frequency boost and attenuation equalization network. Treble control VR-2 and C22, C23 provide for high frequency boost and attenuation. The signal from the tone controls is fed through C6 to pin 2 of IC2. The output of IC2 is coupled through C7 to volume control VR-3, to pin 8 of IC3 through capacitor C28. Feedback for IC2 is accomplished through the network consisting of C8, R12, R10, R11, C27, and R16. From IC3 the signal is fed to TR3, TR4 and TR5. TR6 and TR7 act as complimentary final output drivers to an 8 ohm speaker through capacitor C13. Since this is a single ended common ground output,

(so called O.T.L. — Output Transformer Less-circuit), care should be taken to avoid a ground loop condition which may result in amplifier damage, when connecting the speaker ground to an external earth or electrical ground.

D. Magnetic Record Models (NST-3 & NT-3)

NST-3 & NT-3 models with magnetic record use a special amplifier module which include the bias and erase oscillator circuits. This circuit consists of T1 and oscillator transistors TR8 and TR9.

In magnetic record, the Mag/Rec selector switch set to the No. 3 position. Audio from the speaker jack (14) is routed through the capacitor resistor network C-38 and R-41 to the magnetic record head. At the same time bias and erase current is supplied from the bias oscillator to the combination magnetic playback/record and erase head.





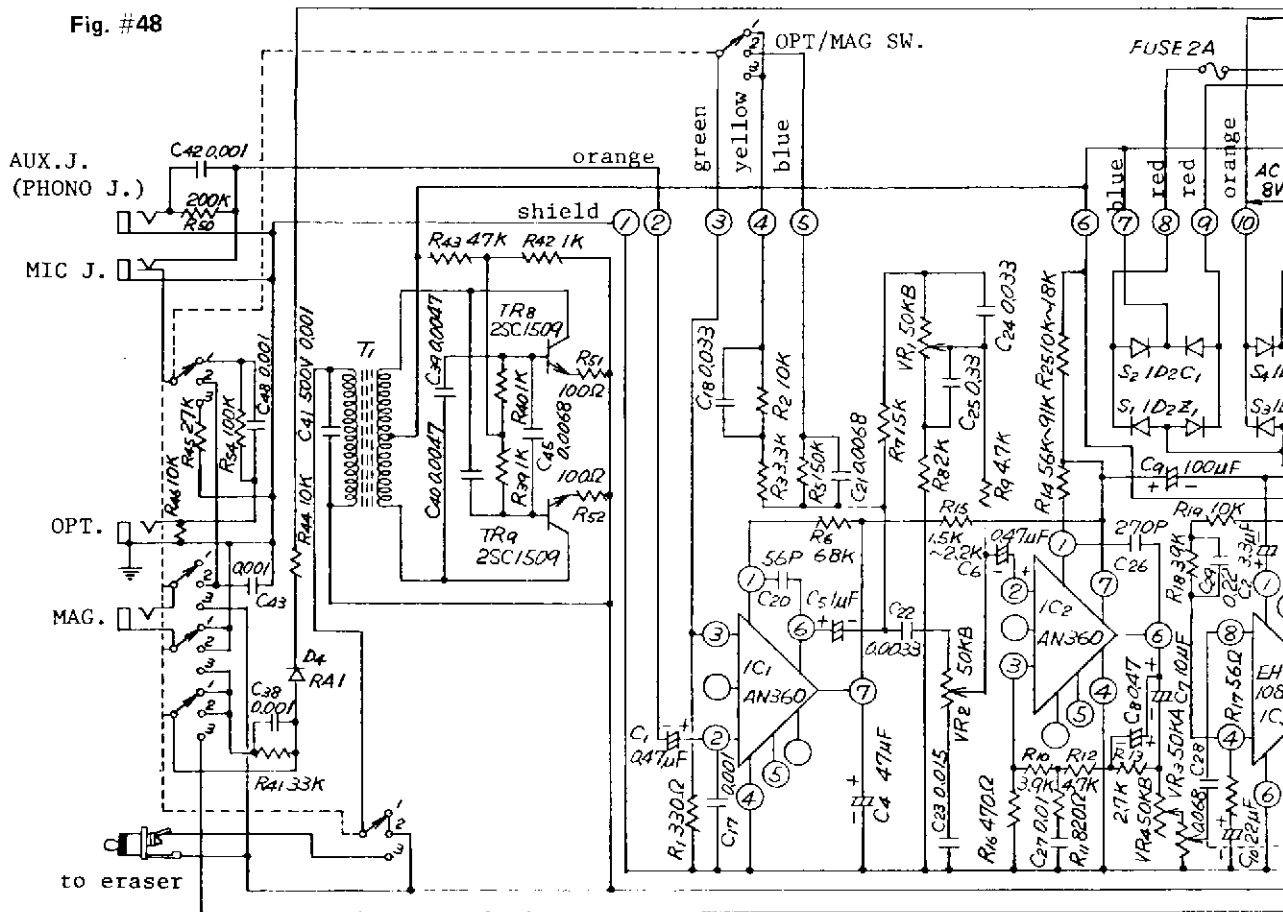















E. Amplifier Circuit Diagrams

1. "N" series Amplifier Diagram (See the end of this manual) p. 73 and p 74
2. "N" series Amp. P.C. Board Block Diagram (See the end of this manual) p. 79
3. "N" series Amp. Frequency Response (See next page)



E-3: "N" Series Amplifier Frequency Response

NOTE: This is one of the typical patterns, and the figure may vary slightly with each projector.

Position of Tone Control		OPT					MAG				
		TREBLE 									
	BASS 										
Frequency Response (400Hz 0db)	50	3.5	-12.0	10.0	8.5	-11.0	1.5	-15.5	6.0	5.0	-14.5
	100	3.5	-7.5	8.0	7.0	-7.0	1.5	-9.0	6.5	5.5	-8.0
	200	0.5	-3.0	4.0	3.0	-3.0	-0.5	-4.5	3.0	2.0	-4.0
	300	0.0	-1.0	1.5	1.0	-1.0	-0.5	-1.5	1.0	1.0	-1.0
	500	1.5	2.0	0.5	0.5	2.0	0.5	1.0	-0.5	0.0	1.0
	1K	3.0	3.0	2.0	1.0	4.0	2.0	1.5	0.0	-0.5	3.0
	2K	3.0	-0.5	3.5	-2.0	5.0	2.0	-1.0	3.0	-2.5	5.0
	3K	2.5	-4.5	4.5	-6.0	5.5	2.0	-3.5	5.5	-5.0	7.0
	4K	3.0	-6.0	6.5	-7.0	8.0	2.0	-5.5	7.0	-7.5	8.5
	5K	0.5	-10.0	5.5	-12.0	6.5	3.0	-6.5	9.0	-8.5	10.5
	6K	-3.0	-15.5	3.0	-16.0	4.5	3.0	-7.5	10.5	-9.5	12.0
	7K	-5.0	-19.0	1.0	-20.0	2.5	4.0	-8.0	12.0	-10.0	13.0
8K						4.0	-9.5	12.0	-11.5	13.5	
9K						3.0	-11.5	12.0	-14.0	13.0	
10K						1.5	-15.0	10.0	-17.0	11.0	

OPT (1)

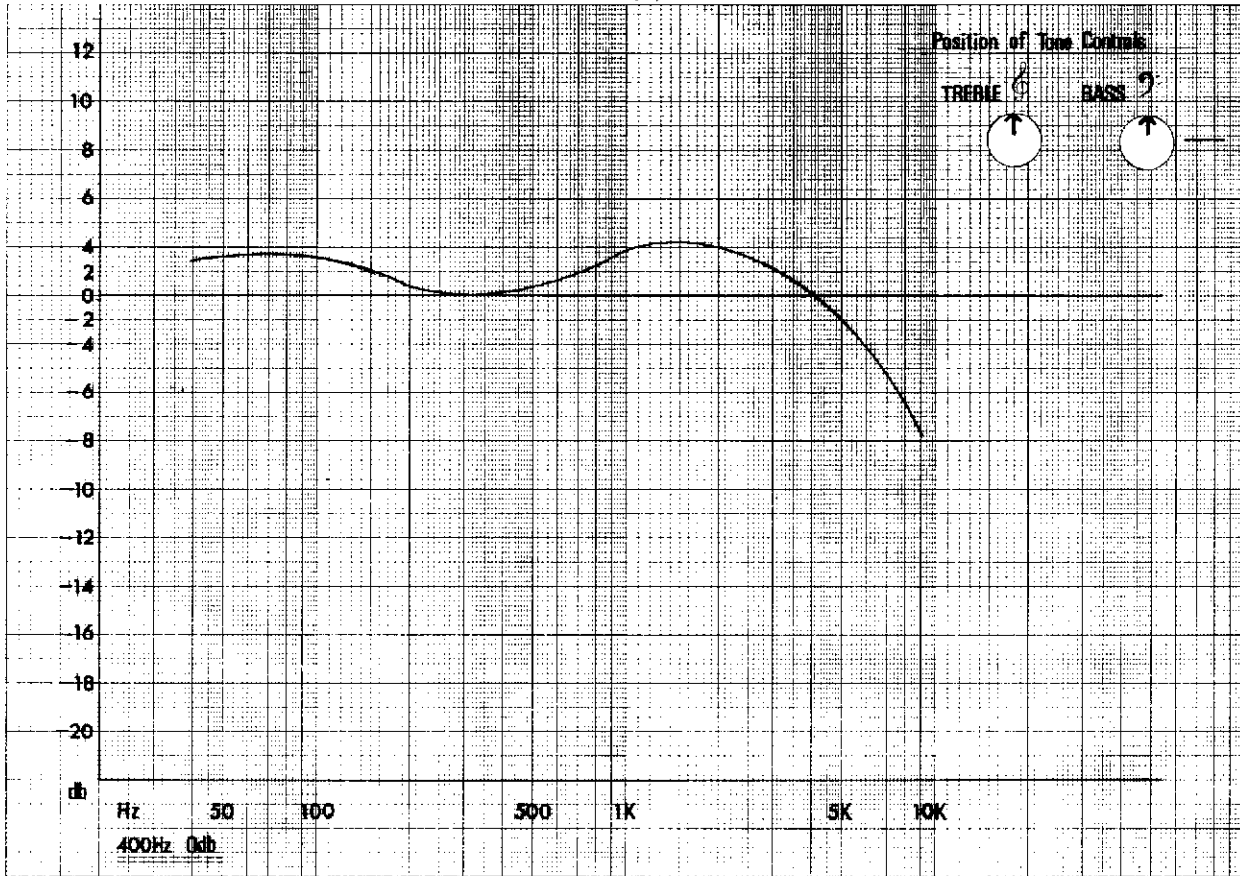

OPT (2)

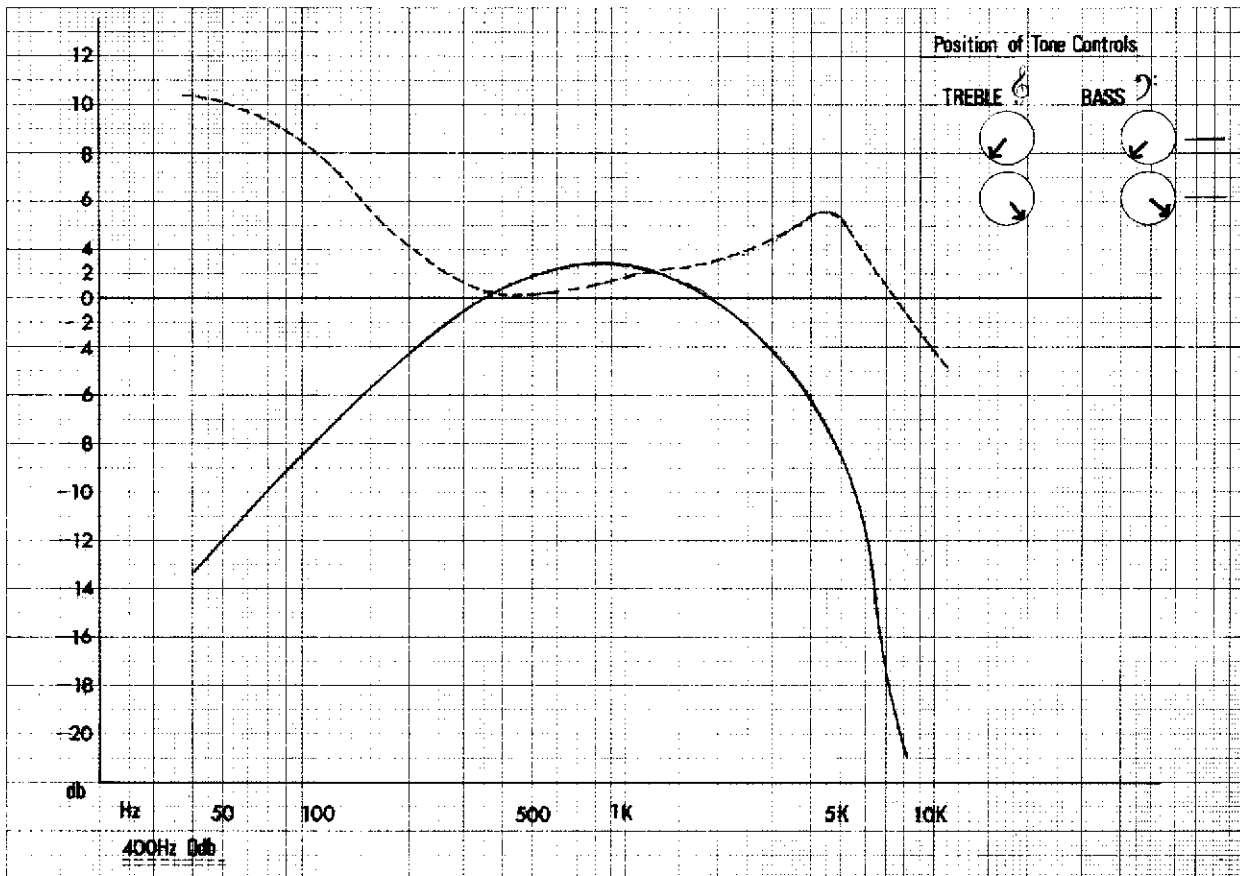

"N" Series Amplifier Frequency Response (typical pattern)

OPT (3)

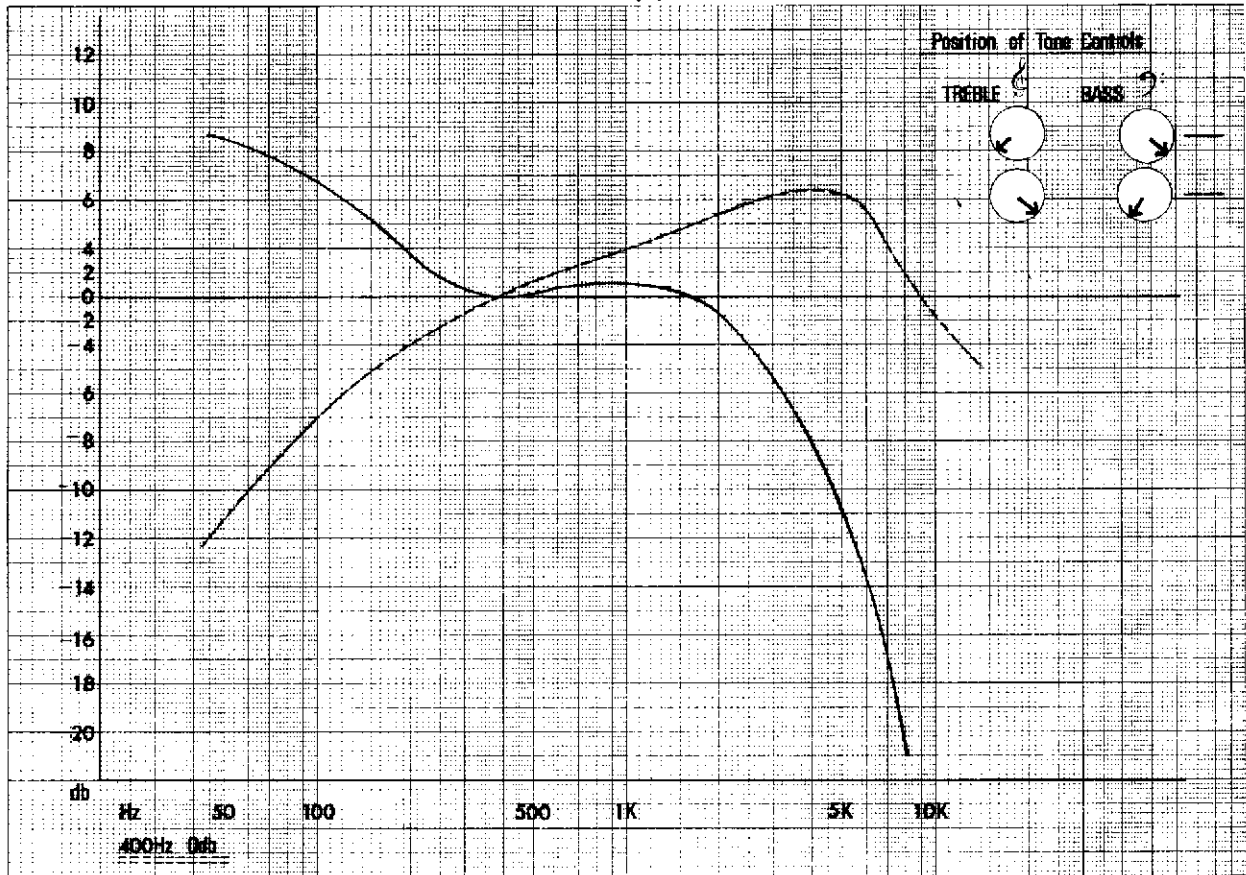

MAG (1)

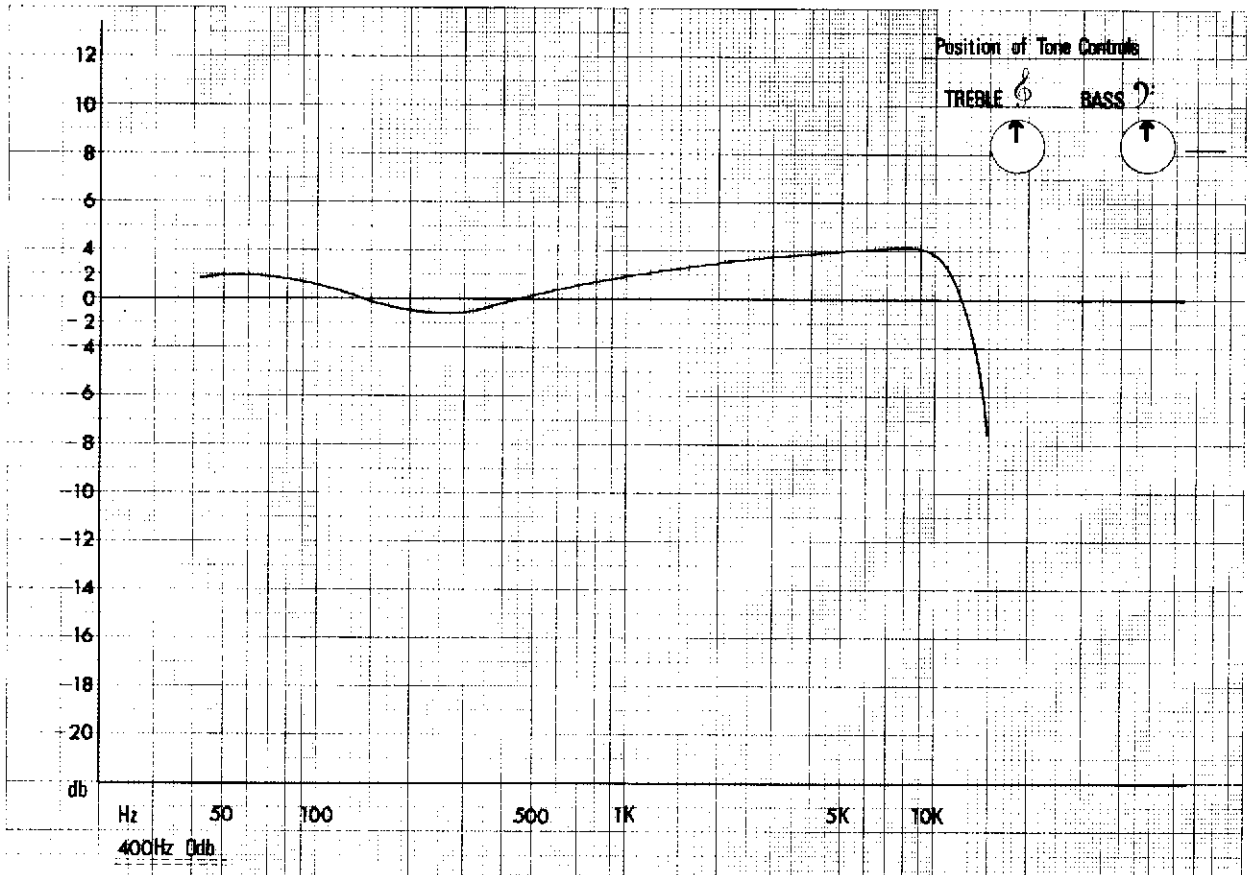

"N" Series Amplifier Frequency Response (typical pattern)

MAG (2)

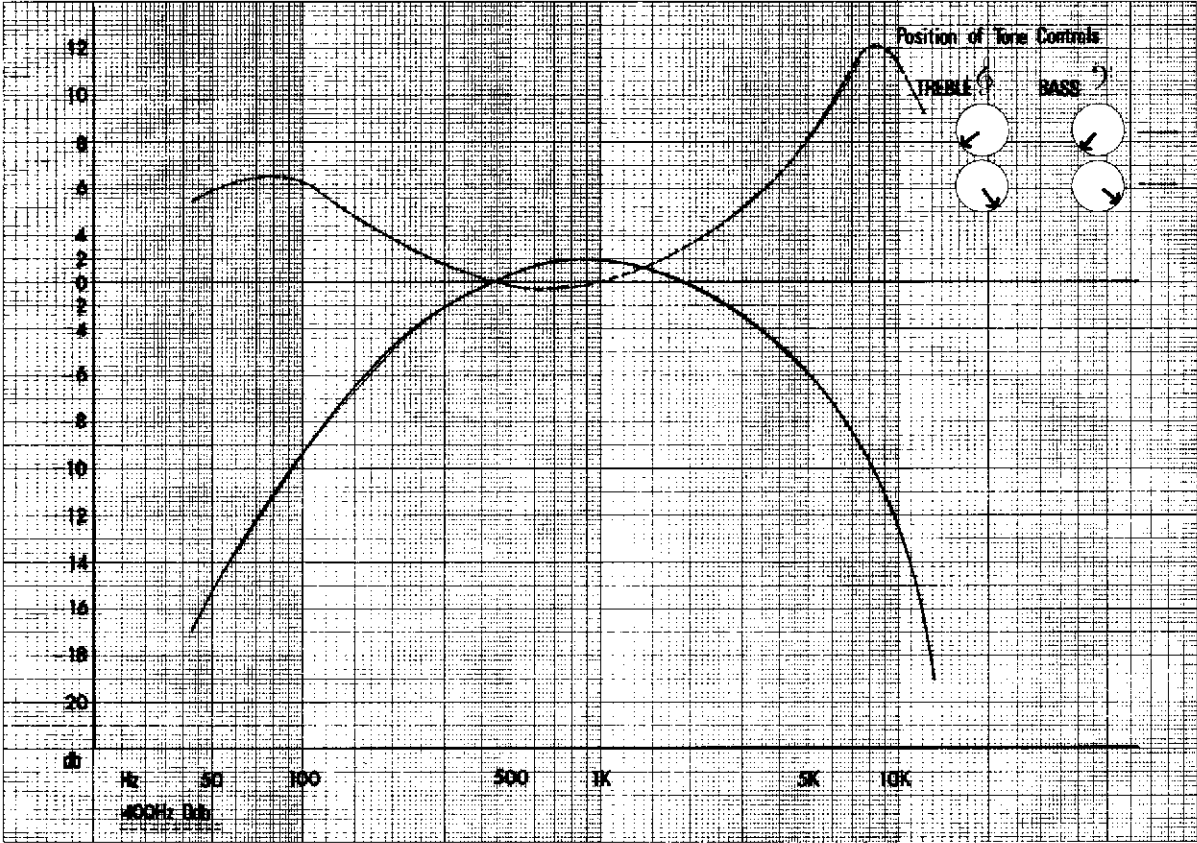

MAG (3)

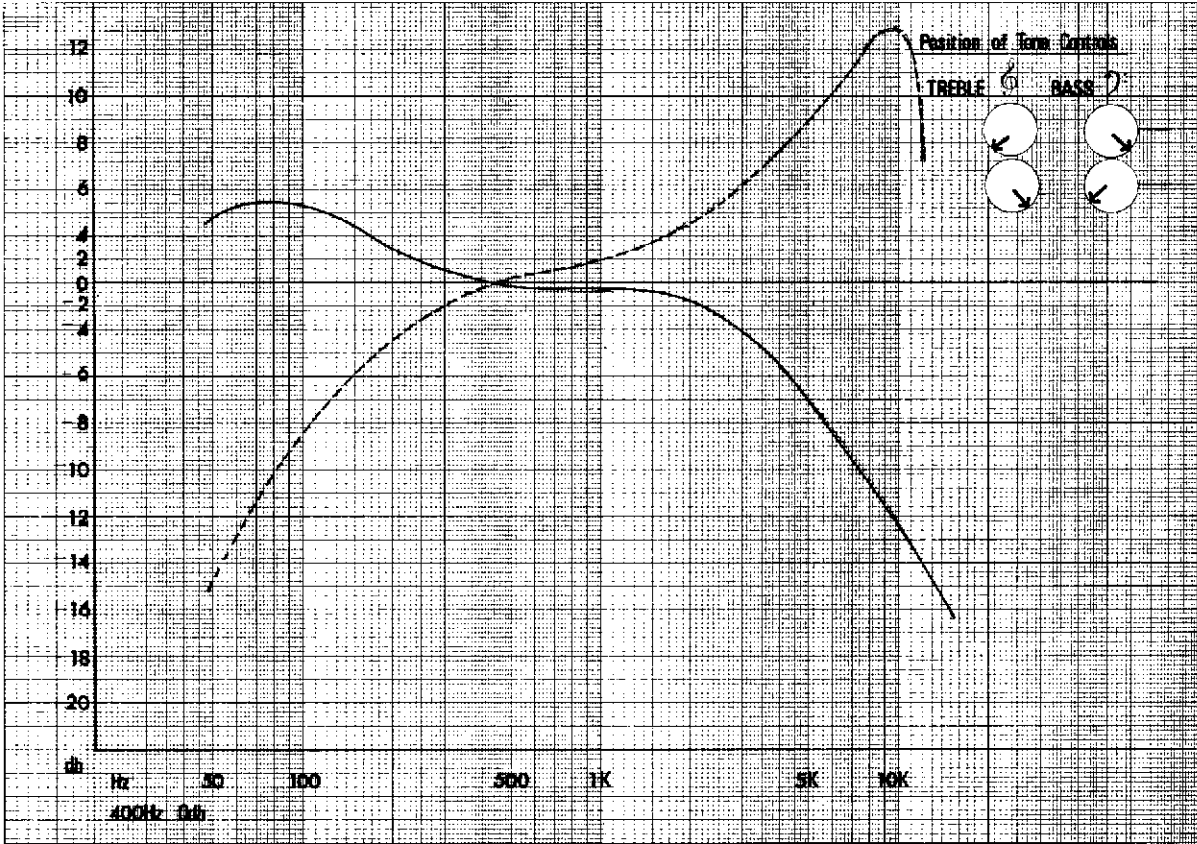

**4-3: MOTOR MODULE**

**A. Specification**

AC Induction type

1/20HP

100 – 120V, and 220 – 240V

Power consumption: 144 – 168W (120V, 1.2A) or  
(220, 240V 0.7A)

Starting Torque: 1.6kg

Rated Torque: 0.8kg

**B. Motor Circuit Diagram**

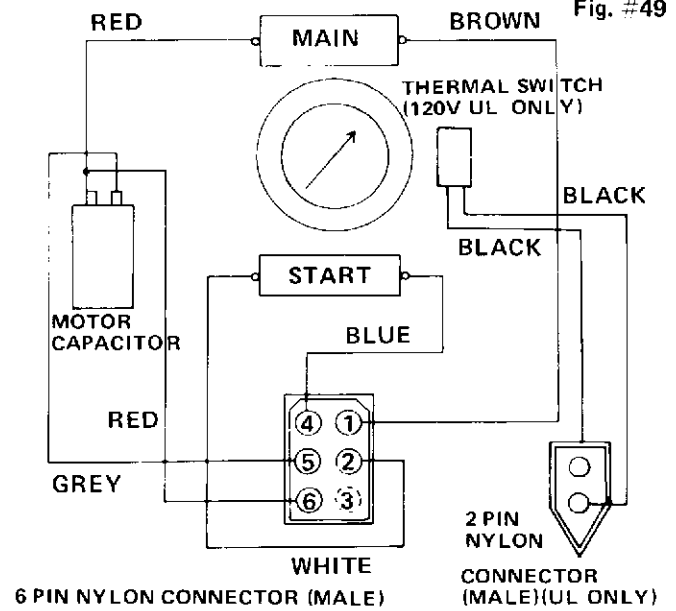

**C. 6 pin Motor Connector (Female) (Fig. #50)**

Pin #	Wire Color	Connected To:
1.	Brown	Micro Switch #1
2.	White	Micro Switch #2
3.	N/C	
4.	Blue	Micro Switch #3
5.	Grey	Micro Switch #3
6.	Red	AC Terminal #4 – #3 (Semko: Terminal Ⓝ)

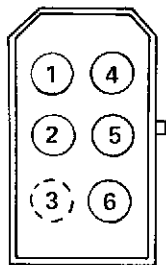

Fig. #50



D. Silent Film Operation And 50 ↔ 60Hz Conversion

1. Silent Film Operation

- a. Disconnect power cord.
- b. Open rear cover. Turn inching knob, at the same time guiding the belt first to the smaller motor pulley then to the larger shutter pulley.
- c. Change back to sound speed by reversing the above procedure.

NOTE: 50/60Hz models do not have silent speed.

2. 50 ↔ 60Hz Conversion

The standard "N" series projector is available either as 50Hz sound and silent or 60Hz sound and silent operations. Conversion from 50 to 60Hz or 60 to 50Hz can be accomplished by changing the motor pulley only.

To allow the projector to be operated at either 50 or 60Hz sound only, it is necessary to change the motor pulley and the cam tank pulley (Shutter Pulley). It is now possible to change frequency by simply shifting the motor drive belt.

The chart below indicates each speed combination:

NOTE: For Dual-Voltage models, such as 110/220V, or 120/240V 50/60Hz, the combination is;

	<u>110/220V</u>	<u>120/240V</u>
	<u>50/60Hz</u>	<u>50/60Hz</u>
Shutter Pulley :	312-11901	312-11901
Motor Pulley :	314-12991	314-12981

**Speed Change Combination Chart**

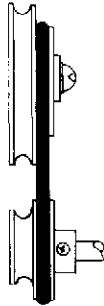
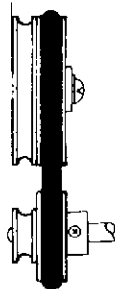
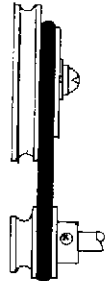
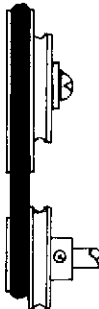
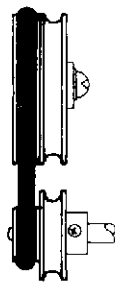
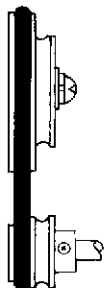
	50Hz Sound & Silent (24fps & 18fps)	50/60Hz Sound/Sound (24fps & 24fps)	60Hz Sound & Silent (24fps & 18fps)
Shutter Pulley	312-11801	312-11901	312-11801
Motor Pulley	312-12921	314-12971	312-12911
	Sound (24fps) speed 	Sound 50Hz 24fps speed 	Sound (24fps) speed 
	Silent (18fps) speed 	Sound 60Hz 24fps speed 	Silent (18fps) speed 

4-4: TRANSFORMER MODULE

A. Transformer Circuit Diagram  
(Earlier Production)

Applicable on;  
NT : S/N 10001 – 26135  
NST : S/N 10001 – 10673

Fig. #51

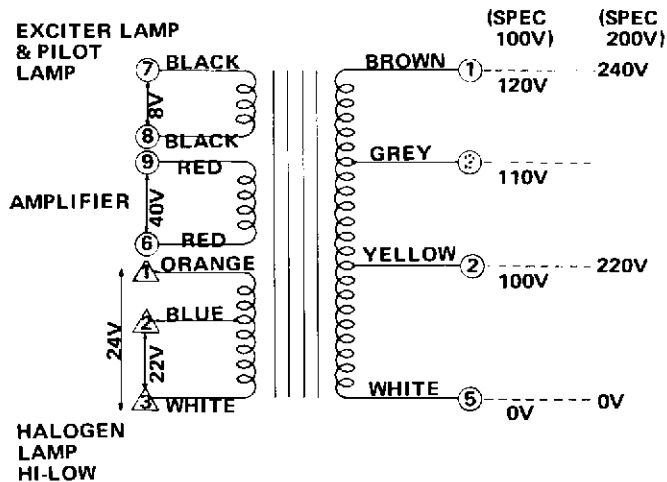

(Later Production)

Applicable on;  
NT : S/N 26136 and up  
NST : S/N 10674 and up

Fig. #52

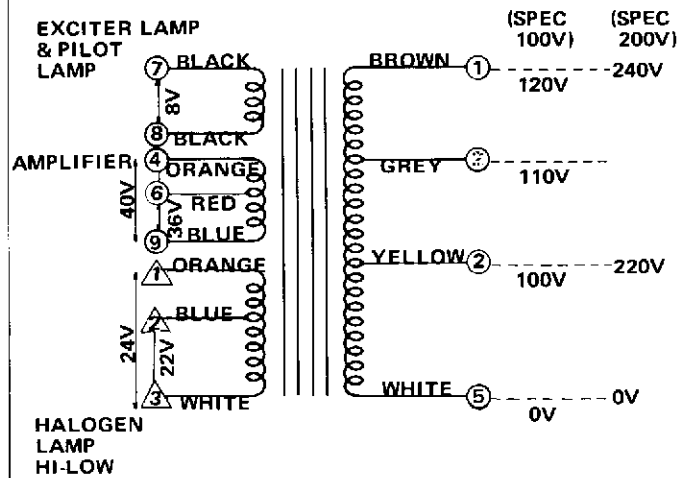

B. Connector Wiring Code  
(Earlier Production)

9 Pin Nylon Connector (Male) (Fig. #53)

Applicable on;  
NT : S/N 10001 – 26135  
NST : S/N 10001 – 10673

Pin #	Color of Wire (for 100V, 120V, 220V, 240V types)	Color of Wire (for 110V type only)
1.	Brown	Brown
2.	Yellow	Grey
3.	N/C	N/C
4.	N/C	N/C
5.	White	White
6.	Red	Red
7.	Black	Black
8.	Black	Black
9.	Red	Red

(MALE) Fig. #53

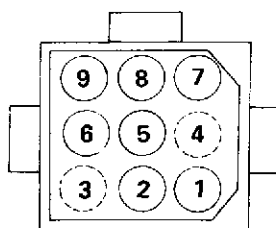

(Later Production)

9 Pin Nylon Connector (Male) (Fig. #54)

Applicable on;  
NT : S/N 26136 and up  
NST : S/N 10674 and up

Pin #	Color of Wire (for 100V, 120V, 220V, 240V types)	Color of Wire (for 110V type only)	Color of Wire (for 120V UL & CSA)
1.	Brown	Brown	Brown
2.	Yellow	Grey	Yellow
3.	N/C	N/C	Grey
4.	Orange	Orange	Orange
5.	White	White	White
6.	Red	Red	Red
7.	Black	Black	Black
8.	Black	Black	Black

(MALE) Fig. #54

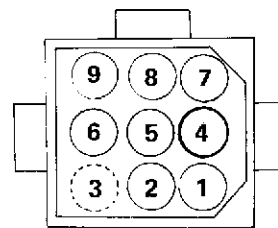

NOTE: Transformers of later production are supplied with the 36V tap connected. To change to the 40V tap, extract pins #4, #6, and insert the orange wire into #6 hole and the red wire to #4 hole.

NOTE: The transformer with AC 36V & 40V taps is identified by the following part numbers;

314-60201a	Transformer	120V
314-60301a	Transformer	110V
314-60401a	Transformer	220/240V
314-60801a	Transformer	220V (FEMKO type)
314-60951a	Transformer	220V (SEMKO type)
314-60981a	Transformer	110/220V (Dual Voltage)
314-60991a	Transformer	120/240V (Dual Voltage)

3 Pin Nylon Connector (Female) Fig. #55  
(for all types) (Fig. #55)

Pin #	Color of Wire
1.	Orange
2.	Blue
3.	White

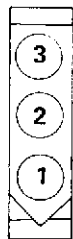

(FEMALE)

3 Pin Nylon Connector (Male) (Fig. #56)  
(for all types)

Pin #	Color of Wire	Connection to:
1.	Red	Micro Switch #5 (Lamp High)
2.	Blue	Micro Switch #4 (Lamp Low)
3.	White	Halogen Lamp

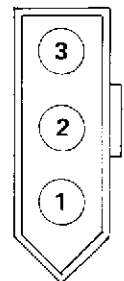

(MALE)

9 Pin Nylon Connector (Female) (Fig. #57)

Pin #	Color of Wire (for 100V, 110V, 120V, 220V, 240V standard types)	Color of Wire (for 120V UL, CSA type)	Color of Wire (for 220V SCAN type)	Connection to:
1.	Brown	Brown	N/C	AC Terminal #1
2.	Black	N/C	Black	AC Terminal #2
3.	N/C	N/C	N/C	
4.	N/C	N/C	N/C	
5.	White	White	White	AC Terminal #4 – #3
6.	Orange	Orange	Orange	MT 9 Pin Socket #1 (or #2)
7.	[ Blue Blue	[ Blue Blue	[ Blue Blue	MT 9 Pin Socket #4 Pilot Lamp
8.	[ Blue Blue	[ Blue Blue	[ Blue Blue	MT 9 Pin Socket #5 Pilot Lamp
9.	Orange	Orange	Orange	MT 9 Pin Socket #2 (or #1)

(STANDARD TYPE) Fig. #57-A

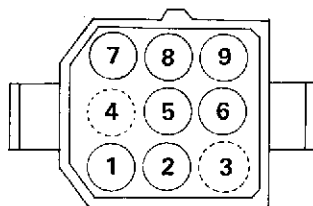

(FEMALE)

Fig. #57-B  
(120V UL & CSA TYPE)

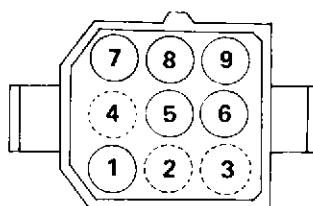

(FEMALE)

Fig. #57-C  
(220V SCAN & SEMKO TYPE)

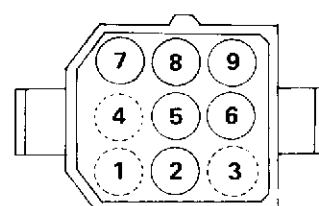

(FEMALE)

4-5: LENS AND GATE MODULE

A. Film Gate Assembly

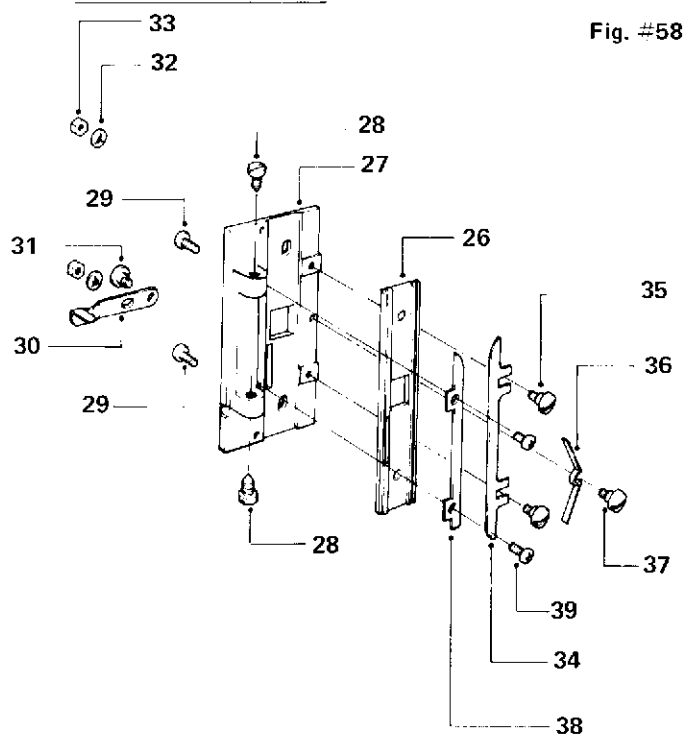

Fig. #58

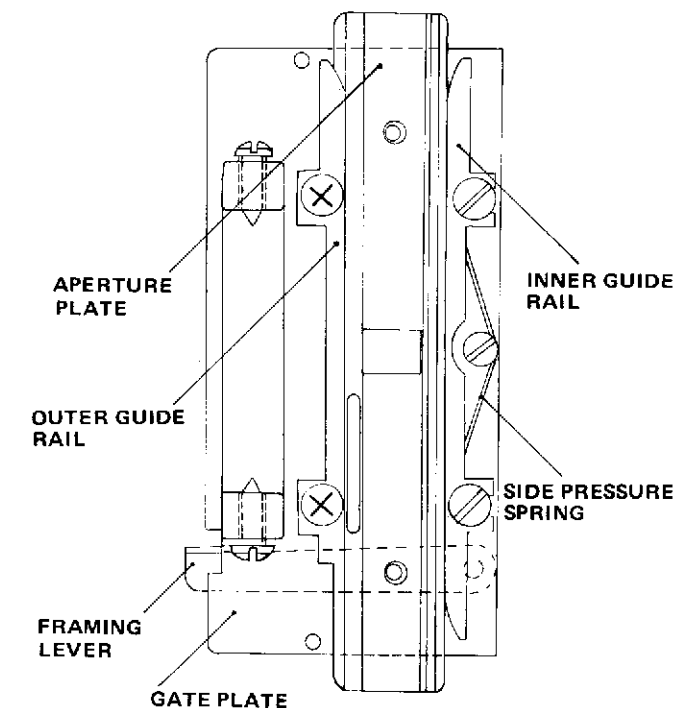

Fig. #59

The film gate assembly consists of the aperture plate (26), framing lever (30), inner (34) and outer (38) guide rails and the film gate plate (27). The film gate assembly maintains close contact with the film and must be kept free from accumulated dust

or dirt. The aperture plate (26) is mounted to the gate plate by two nuts, allowing it to slide up and down with the framing lever. The outer guide rail (38) is fixed to the gate plate by two screws. The inner guide rail (34) is movable and is mounted by two shoulder screws and is adjusted by the side pressure spring (36).

1. Adjustment Of The Inner Guide Rail:

The tension of the inner guide rail is determined by the side pressure spring (36) about 60 – 70 grams. Excessive tension will cause early film wear, while insufficient tension causes an unsteady picture. The tension can be increased or decreased by slightly bending the spring. A weak or incorrectly formed spring should be replaced.

2. Adjusting The Outer Guide Rail Position:

Unless the gate plate has been removed or the outer rail has been replaced, no adjustment should be required. To adjust, thread a SMPTE registration test film and align the center of the frame with the center of the aperture by adjusting the position of the outer rail. It may also be necessary to re-position the claw (See Sec. 4-1-D)

B. Film Shoe And Lens Holder Assembly

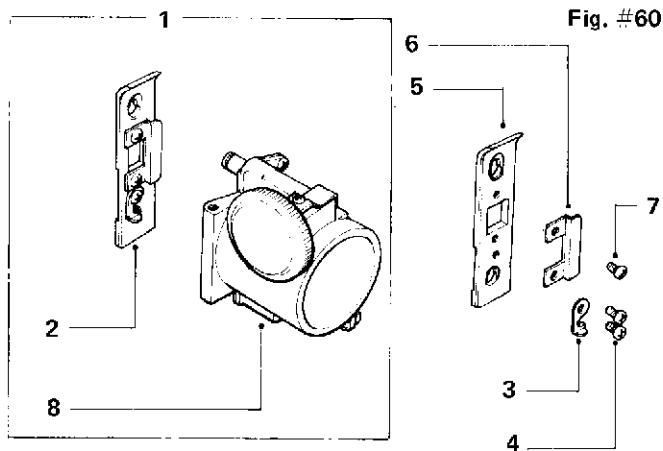

Fig. #60

1. Film Shoe (Fig. #60)

The film shoe assembly (2) consists of the film shoe (5), the threading release plate (6) and the shoe lock (3). The film shoe assembly is easily removable with the shoe lock for cleaning or replacement. It is important that the shoe be kept clean and free to seat squarely against the aperture plate. The threading release plate engages with the self-threading mechanism to release the film shoe during threading.

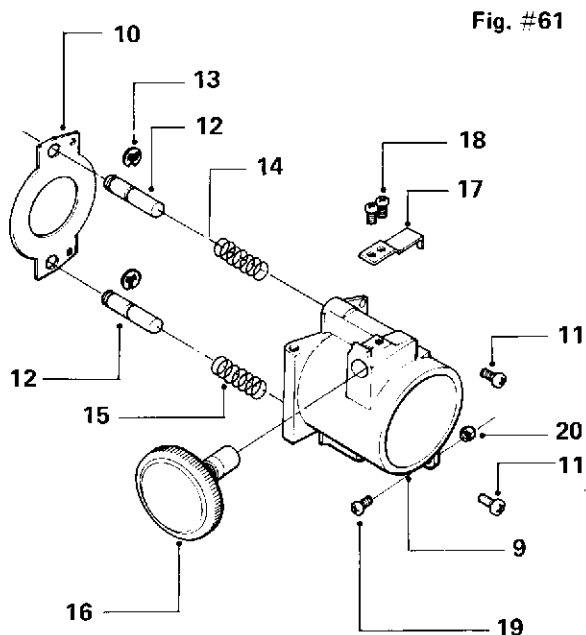

Fig. #61

## 2. Lens Holder (Fig. #61)

The lens holder consists of the lens holder barrel (9), the focus knob (16) and the lens friction drive pinion, the upper and lower shoe pins (12) and springs (14) and (15).

## 3. Adjustments

### a. Film Shoe Pressure

The pressure of the film shoe against the film is maintained by the tension springs (14 & 15) located behind the shoe pins (12). Excessive film shoe tension will cause unnecessary film wear, insufficient tension can cause an unsteady picture, excessive film gate noise and uneven or erratic focus. To test the film shoe pressure retract the cam claw, insert a strip of film in the gate and close the gate. Attach a gram scale to the end of the film at the top. A gentle steady pull should produce about 90 to 110 grams of pull, indicating the correct film shoe pressure. To adjust the pressure, stretch, shorten or replace the shoe springs.

**NOTE:** The upper spring is shorter than the lower spring. The extra tension of the lower spring is designed to overcome the film movement caused by the claw action at the lower end of the film shoe. It is important the shoe pins move freely in the lens holder. If not, clean away any dirt or grease restricting its free movement. Do not lubricate.

### b. Film Shoe Position

When the gate is closed the film shoe should line up along the edge of the outer guide rail and seat flat against the aperture plate. To adjust the position of the film shoe, loosen the retaining plate screws (11), close the film gate and insert one film thickness between the outer rail and the film shoe. (Fig. #62)

Reposition the retaining plate to obtain moderate tension on the film and secure the retaining plate screws (11). Open and close the gate to be sure the film shoe seats completely.

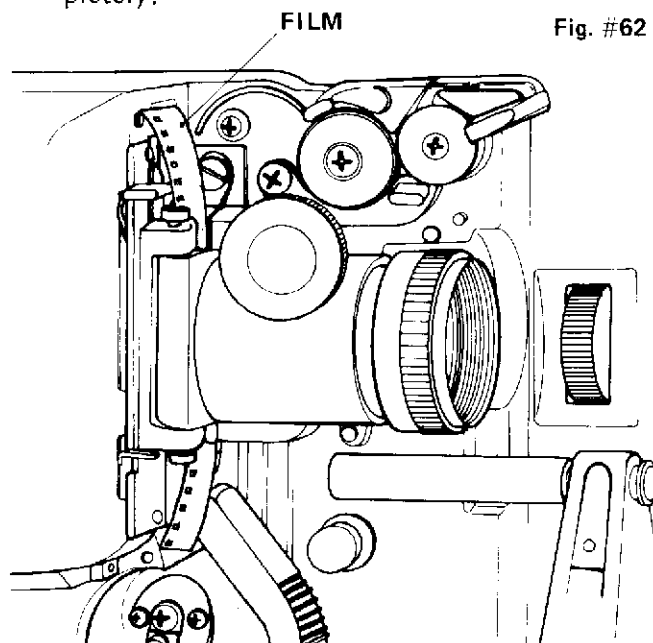

Fig. #62

### c. Uneven Focus

Uneven focus occurs whenever the image on the film is not flat and perpendicular to the optical path. To adjust the axis of the lens to the aperture plate, set the projector to exact right angles to the screen. Without a film in the gate, project an image of light on a screen at least 3' or 1m wide. Focus the edges of the image. If both sides are not focused equally, adjust the lens holder index screw and lock nut (19 & 20) to achieve optimum equal focus.

**NOTE:** Fast lenses such as the standard f/1.2 50mm (2") require more precise adjustments than slower lenses.

### d. Lens Holder Hinge Adjustment

The lens holder provides for automatic closing of the No. 1 film shoe when manually thread-

ing the projector and restricts the opening of the film shoe during the self-thread operation. Too tight a clearance does not allow for easy film threading or removal, and may possibly puncture the film between the perforations during self-thread. The clearance between the No. 1 film shoe and the lens holder should be no less than three film thickness. (Fig. #63) To adjust, open the lamp house door and loosen two set screws behind the gate plate (29 of Fig. #58, and Fig. #63), and slightly turning the upper and lower pivot screws (28 of Fig. #58, and Fig. #63) adjust the lens holder's position to obtain the correct clearance. The pivot screws should be snug against the lens holder.

Fig. #63

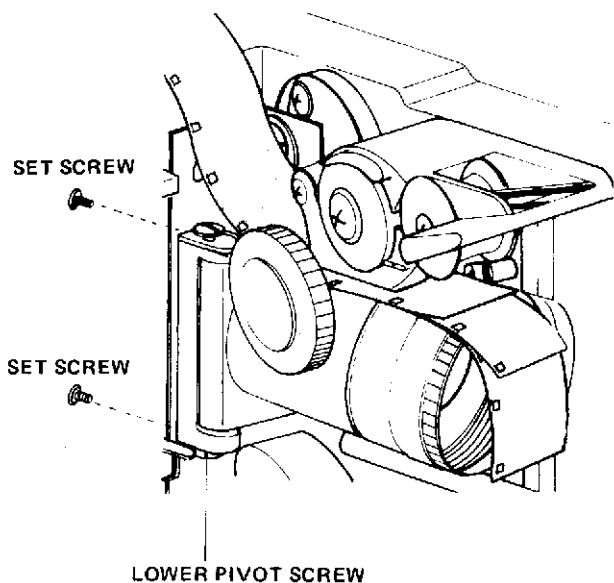

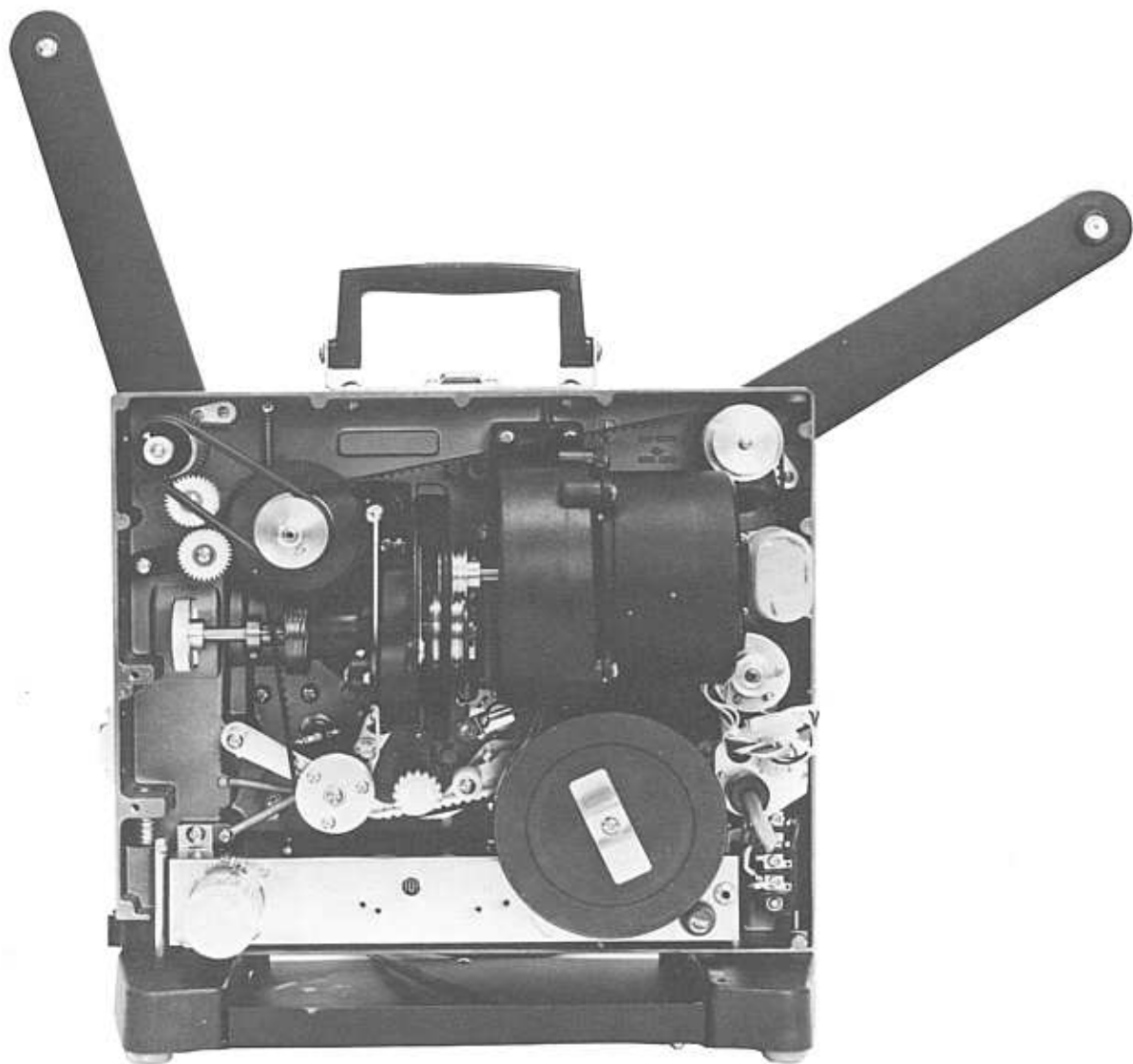

# 314-5: GENERAL MECHANICAL SERVICING AND ADJUSTMENTS

"N" Series  
(5-1-B)

## 5-1: TAKE-UP ARM ASSEMBLY

### A. Description (Fig. #64 & 65)

The drive to the take-up arm is obtained through the take-up clutch mechanism (Items 11, 12 and 13). In forward and rewind the clutch cam (12) is engaged, driving the belt and take-up pulley (18) in a clockwise direction for normal film take-up. In reverse the clutch cam (12) is disengaged, removing all drive to the take-up pulley (18). The amount of torque required to take-up a film is proportioned to the weight and diameter of the reel. As the weight of the film pack increases the friction between the spindle assembly (14) and the take-up pulley (18) increases to provide the necessary torque to take-up reels up to 2000ft or 600m.

### B. Adjustments

#### 1. The take-up torque

The take-up torque is automatically controlled by the weight and size of the film pack, however, for this to function properly it is essential that the take-up pulley (18) be well lubricated and free running on the bushing. The cork liner

in the spindle assembly (14) must be well lubricated to provide a smooth, even take-up. Excessive take-up tension is caused by insufficient or improper lubrication of the cork liner. Weak or no take-up may be caused by a worn cork liner or oily belt. Refer to lubrication chart for proper lubrication.

Fig. #64

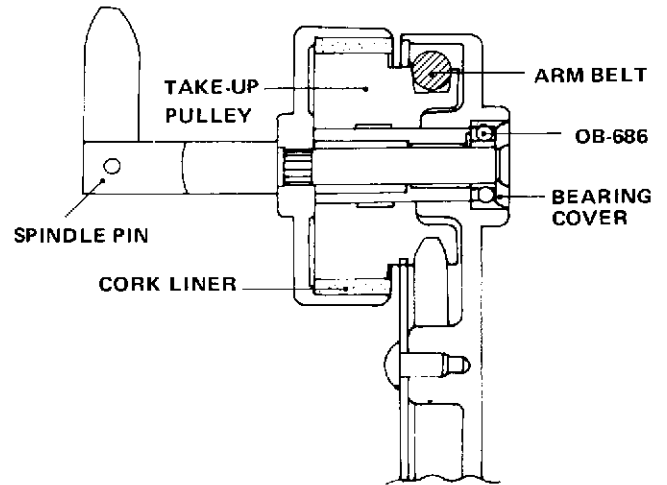
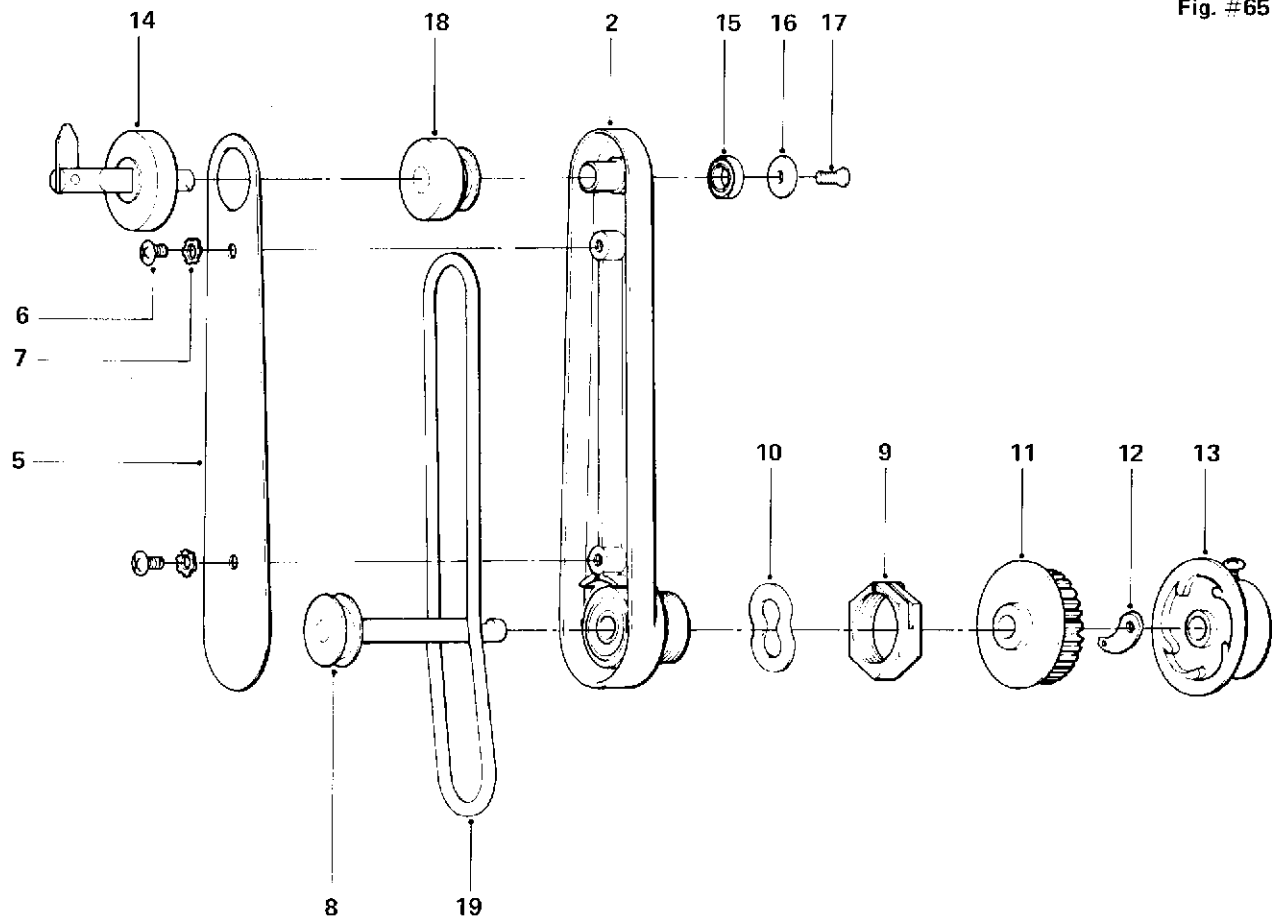

Fig. #65





2. Take-Up Clutch Mechanism:

The take-up clutch mechanism requires no lubrication. The clutch cam (12), clutch cover (13), and drive gear (11) should be kept clean and free from dirt. A small amount of silicone oil on the drive pulley shaft is sufficient (see lubrication chart). When re-assembling the clutch mechanism, it is important that the clutch cam be positioned correctly. A space of 0.2mm is required between the drive gear and clutch cover. (Fig. #66 & 67)

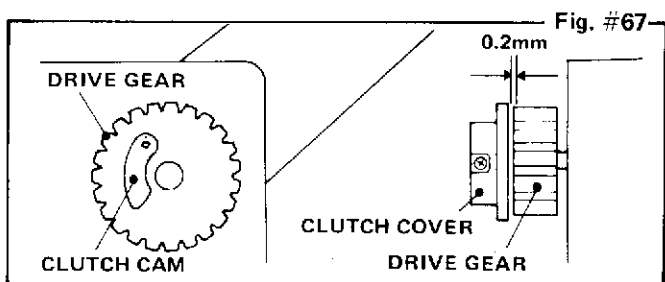
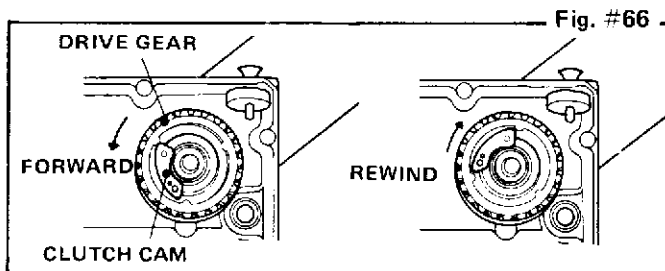

to the film. The amount of back tension is controlled by the cork disc (17) spring (20) and the adjustment of the knurled nut (22). In reverse the motor reverses direction engaging the reverse drive clutch (18) and the reverse belt drives reverse pulley (19) which is clutch coupled via the cork disc (17) to drive the pulley (8) and spindle (23) providing reverse film take-up.

In rewind the drive to the supply arm is accomplished through upper and lower rewind gears which are engaged when the rewind lever is in the rewind position. (Fig. #69 & 70)

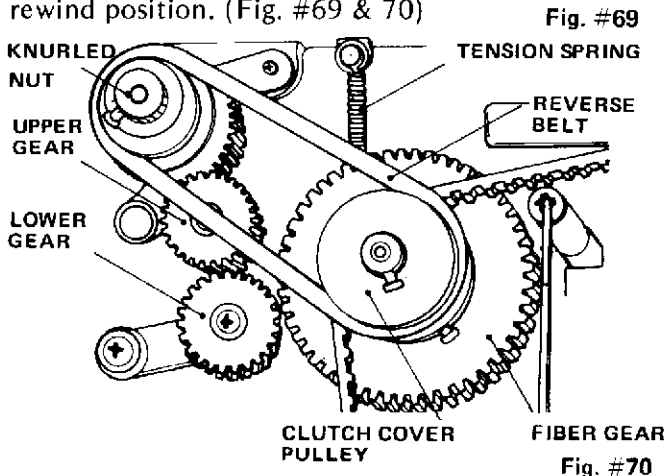

5-2: SUPPLY ARM

A. Description: (Fig. #68)

During forward the supply arm only serves as a drag to provide a small amount of back tension

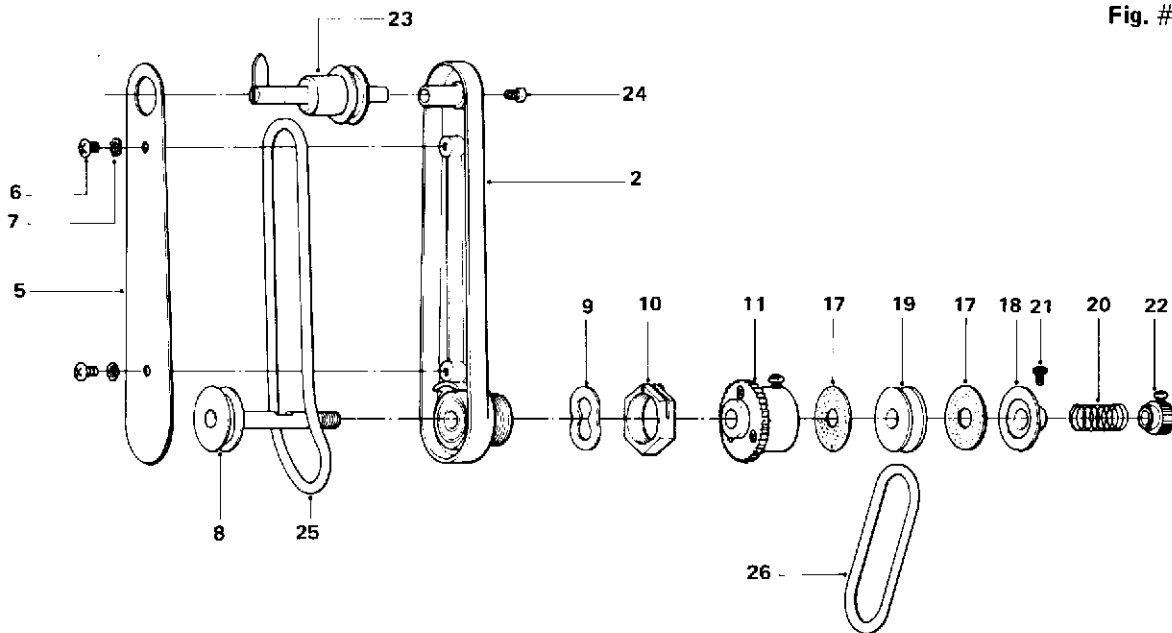
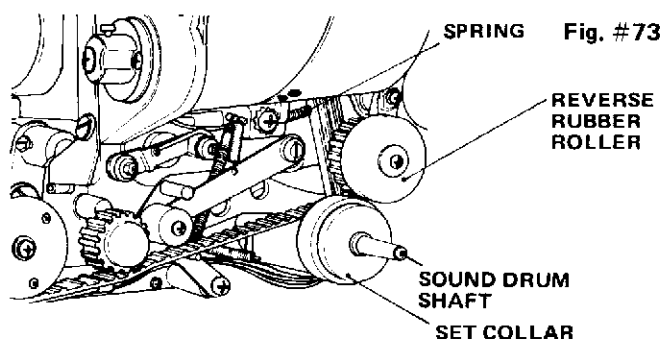

Fig. #68

**B. Adjustments:**

The supply spindle should be lubricated with petroleum oil (see lubrication chart). The belt must be clean and free from oil or dirt. Oily belt may result in poor rewind. The knurled nut (22) adjusts the back tension to the supply reel, too little back tension will result in uneven or jerky film feed and weak reverse take-up tension. Adjusting the knurled nut effects both the reverse take-up and the supply tension. Correct adjustment will be a compromise.



Driving the flywheel is necessary to maintain the lower loop when operating the projector in reverse. In normal forward projection the main drive belt carries the reverse rubber roller and bracket assembly (15) away from the set collar where it can rotate freely. The rubber roller must not be in contact with the set collar in the forward mode. (See Sec. 5-7-A)

**B. Adjustments:**

The reverse take-up clutch requires no lubrication except the bushing of the clutch cover pulley (18). (See lubrication chart). When re-assembling the reverse take-up clutch mechanism, it is important that the clutch cam (19) be positioned correctly. A space of approximately 0.2mm is required between the drive gear assembly (8) and the pulley (18). This is determined by the position of the set collar (20).

**5-3: REVERSE PROJECTION**

**A. Description**

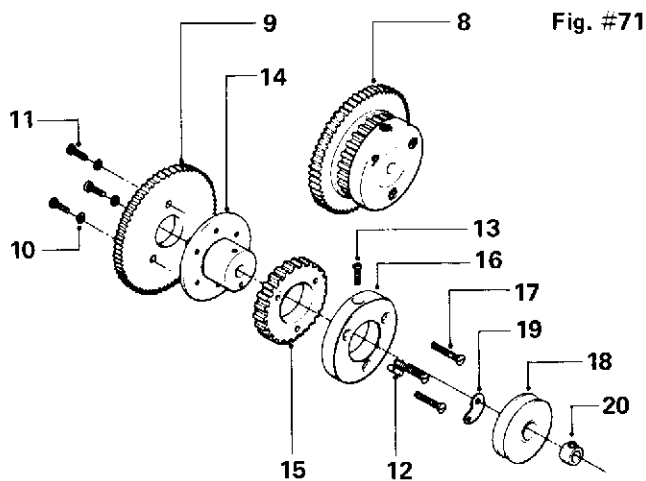

In reverse the motor rotates in a counter-clockwise direction engaging the reverse take-up clutch cam (19) which in turn drives the clutch cover pulley (18), driving the reverse belt. At the same time the main drive belt drives the reverse rubber roller (15 of Fig. #72 & Fig. 73) against the set collar behind the flywheel, thereby driving the set collar or the sound drum in the counter clockwise direction.

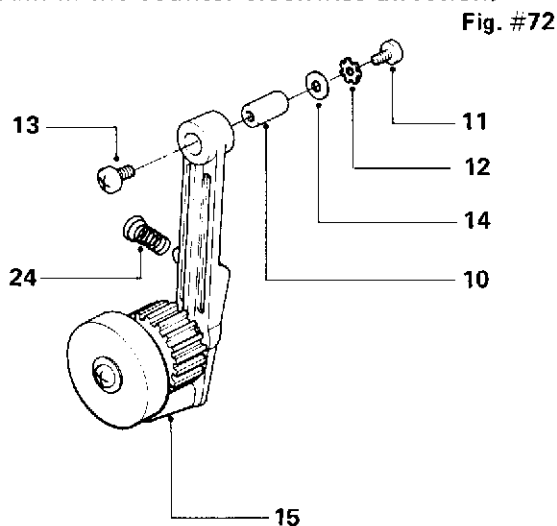
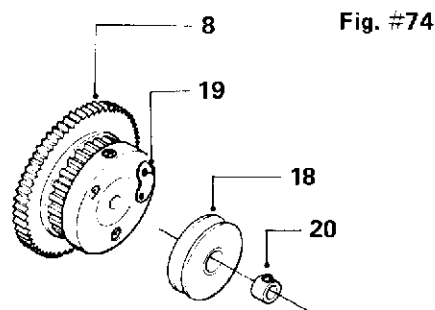

The reverse rubber roller requires no adjustments as long as the main drive belt is in contact with the roller's drive gear. The spring (24) is required to maintain enough pressure to assure the gears contact with the main drive belt. It may be necessary to stretch this spring to assure that the roller has cleared the set collar in the normal forward position and that it drives the sound drum during reverse. This action can be observed by operating the mechanism manually via the inching knob and with the flywheel removed. The rubber roller should be clean and free from any grease or oil. A dry or glazed roller should be replaced.

### 5-4: LOWER LOOP SETTER SYSTEM

#### A. Description

Torn or damaged sprocket holes in a film will cause the lower loop to be shortened. When this occurs, the film pull down will be out of sequence with the shutter causing a jitter or jumping picture. When this occurs the automatic loop setter will reset the lower loop again bringing the film under control of the pull down mechanism.

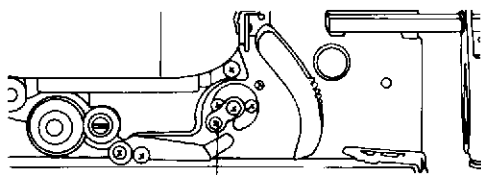

Fig. #75

LOWER LOOP SETTER ROLLER  
"7:30 O'CLOCK" POSITION

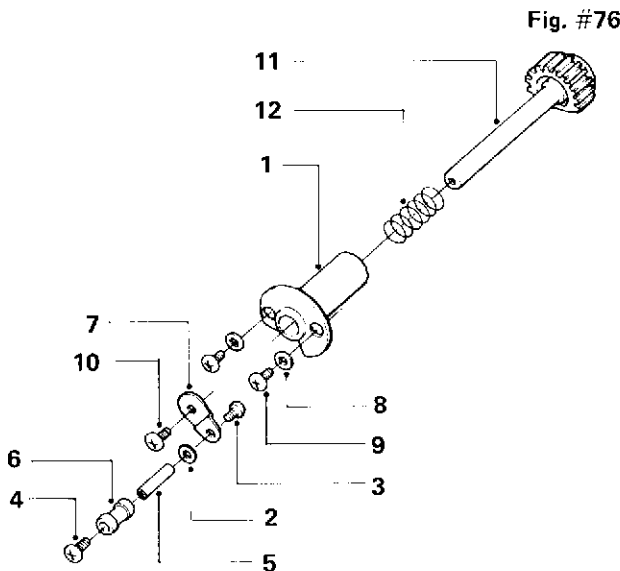

Fig. #76

The automatic loop setter consists of the setter roller (6), the hub assembly (1) and the gear and shaft assembly (11). When the lower loop is shortened one complete frame or more, the film applies pressure on the setter roller (6) which in turn causes the eccentric gear (11) to engage, rotating the setter roller one complete revolution, pulling down on the film thus re-establishing the correct lower loop. Additional rotations may indicate severely damaged film or incorrect loop setter adjustments.

#### B. Adjustments

In the normal operate position with good film the loop setter roller should rest at approximately 7:30 o'clock (Fig. #75), with the flat side of the

gear (11) parallel to the main drive belt with approximately 0.5 to 1mm of clearance. The belt must ride flat with respect to the gear. If not, the tension gear and arm assembly is not aligned correctly. To correct this condition it may be necessary to reform the tension gear arm. With the belt and gear parallel the loop setter roller is adjusted to the 7:30 position by loosening the arm position screw (10). While holding the gear in place, adjust the arm position and secure the screw. Operate the projector without film. If the loop setter rotates more than once with a small amount of upward pressure, the spring (12) tension is too loose. Remove the spring and slightly stretch or replace it. Re-adjust and test again.

#### C. Loop Setter Timing:

Correct timing is required for proper operation of the loop-setter. Set the projector to self-thread. Turn on the projector and insert a 2 - 3 meter strip of good film. When threaded, release the threading mechanism. Observe the loop setter should only rotate once. Continued rotation indicates too small a lower loop. Too large a loop will not reset the loop when missing or damaged sprocket holes are present. The size of the lower loop is determined by the relationship between the claw and the #2 sprocket drive.

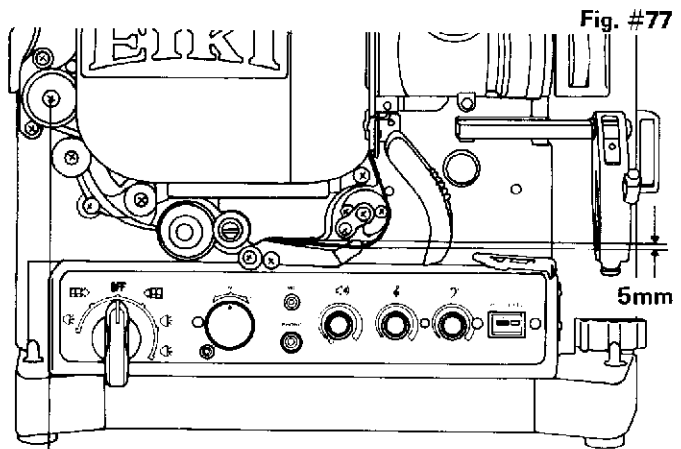
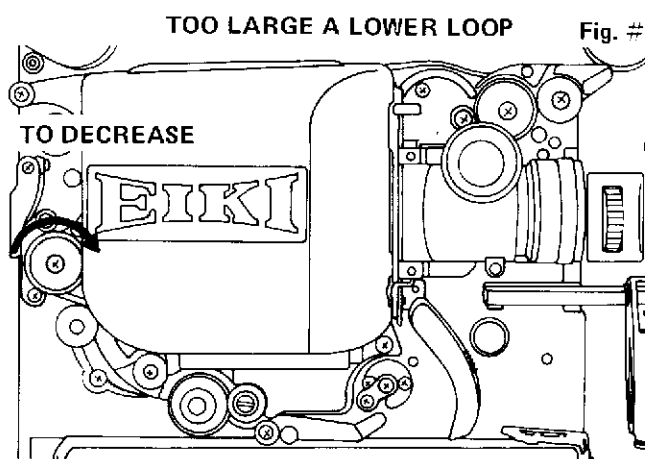
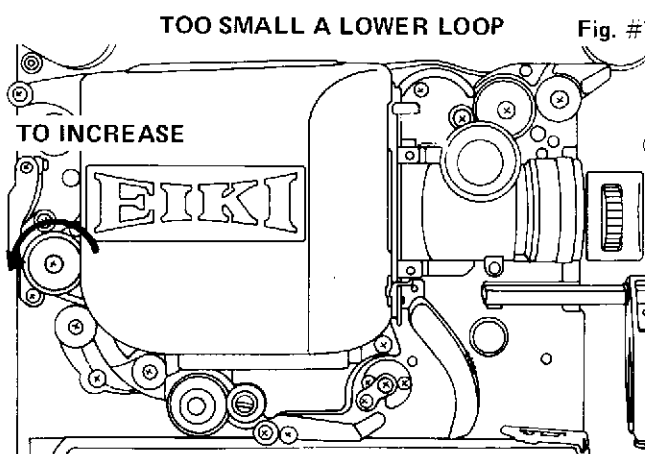

Fig. #77

#2 SPROCKET  
COVER SCREW

To increase the lower loop size, stop the projector, loosen the #2 sprocket cover screw, slightly rotate the sprocket teeth plate counter clockwise (Fig. #78). To decrease the loop, rotate the sprocket teeth plate clockwise (Fig. #79). Tighten the cover screw. Unthread the projector, re-thread and release the threading mechanism. It may require several repeat adjustments to achieve approximately 5mm of clearance between the loop and the loop setter roller (Fig. #77). Correct timing will result in one loop setter cycle when two successive damaged sprocket holes or a bad splice pass through the gate. In some cases continuous cycling of the loop setter may be caused by very poor or damaged film or too strong a take-up tension. Excessive take-up tension may cause the film to skip over the sprocket drive resulting in lower loop loss. (See Sec. 5-1).



### 5-5: SELF-THREADING MECHANISM

#### A. Description:

The self-threading mechanism is activated by pushing the #2 film guide (12) into the thread position, locking the interlocking bracket (14) to the release bracket (8).

At the same time the #1 film guide (1) is extended from behind the casting to guide the film into the film gate while forming the upper loop. The film shoe is released by plate (8) and the claw is retracted out of the gate by plate (7). Film guide #2 (12) lines up with guide #3 (22) and the rubber pinch roller (33) is released from the sound drum.

The loop setter is locked out by the safety arm assembly which exerts a downward pressure against the main drive belt preventing the loop setter gear from activating the loop setter during the threading

operation. The lower portions of the lamp house cover provide the guides necessary to complete the threading. To thread, turn the function switch to forward, set the #2 film guide to thread, insert the film into the film channel. When the film exits at the last roller, a light tug releases the threading mechanism. The projector is now ready to operate, the safety arm is released and the loop setter is activated, the film shoe and claw lever is also released. The tension around the sound drum is automatically controlled by the tension of the rubber pinch roller.

Fig. #80

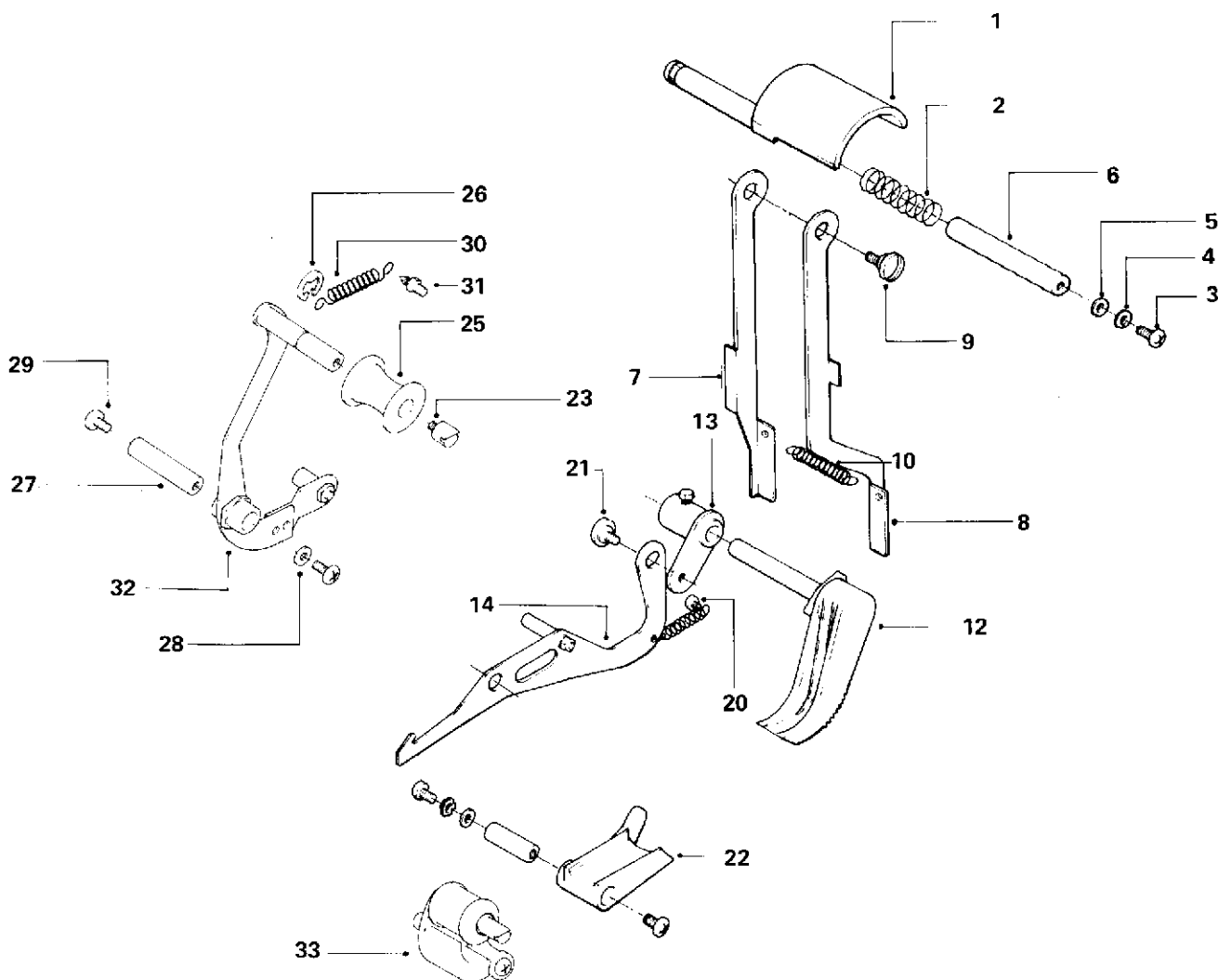

### SELF-THREAD FILM PATH

Fig. #81

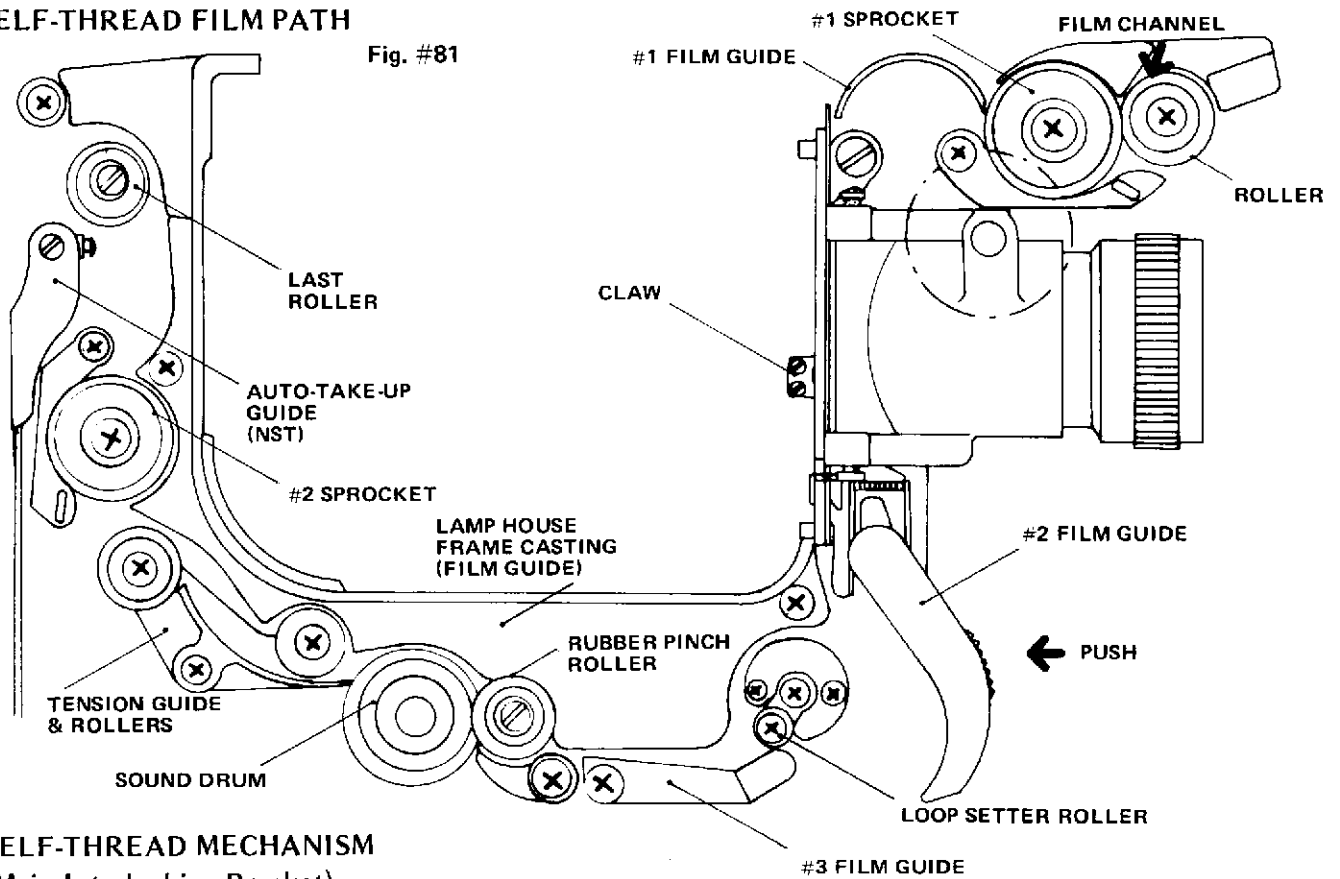

### SELF-THREAD MECHANISM (Main Interlocking Bracket)

Fig. #82

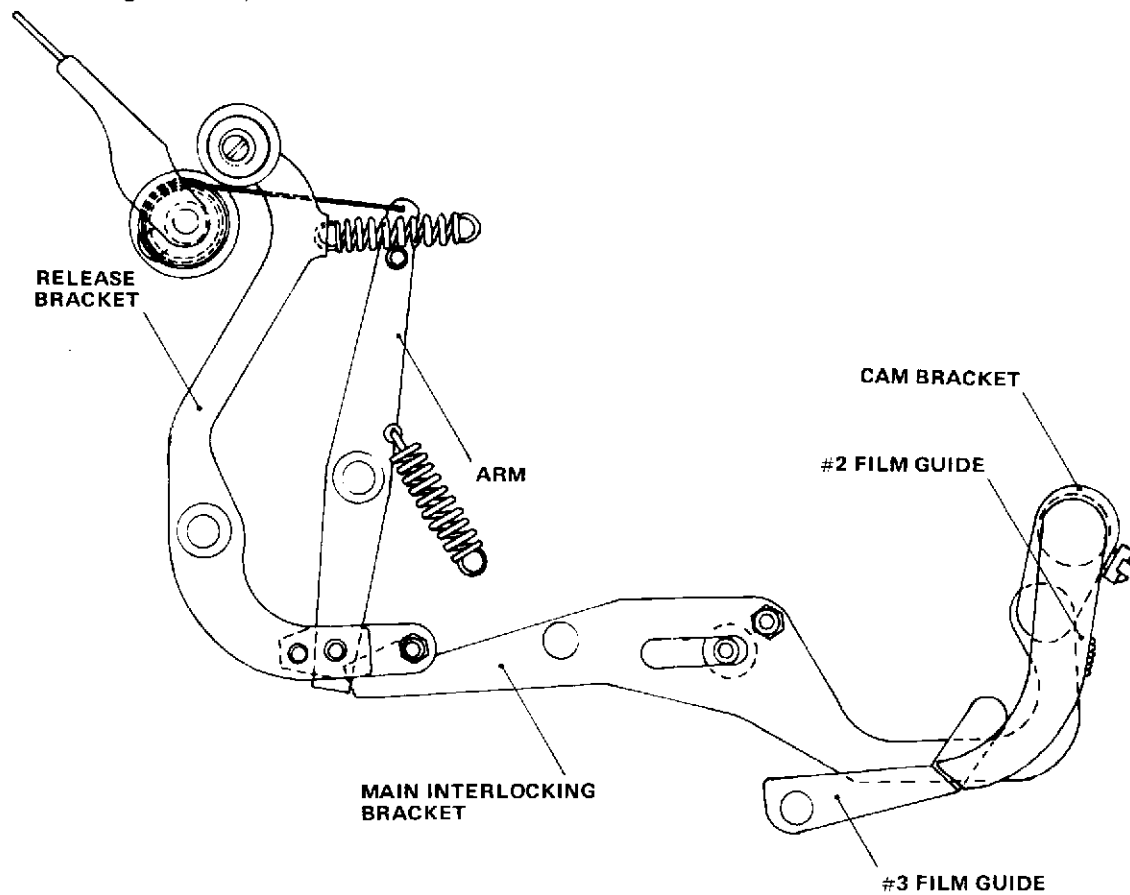

Cam Claw Retraction  
Mechanism

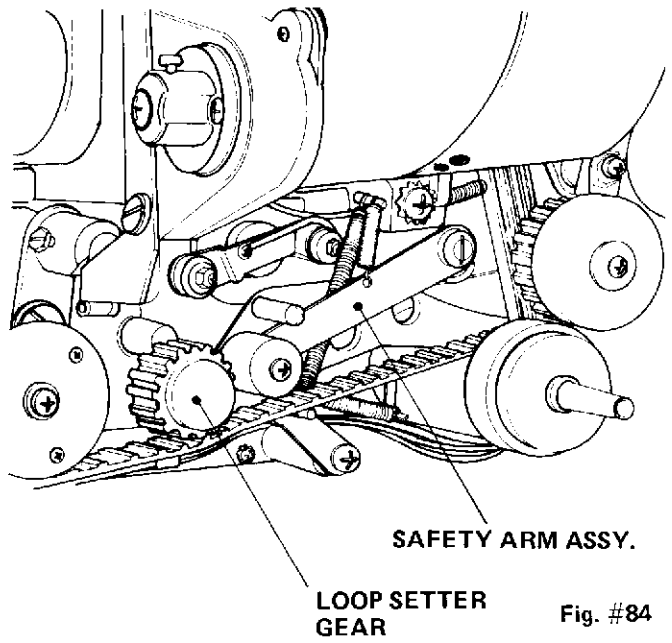
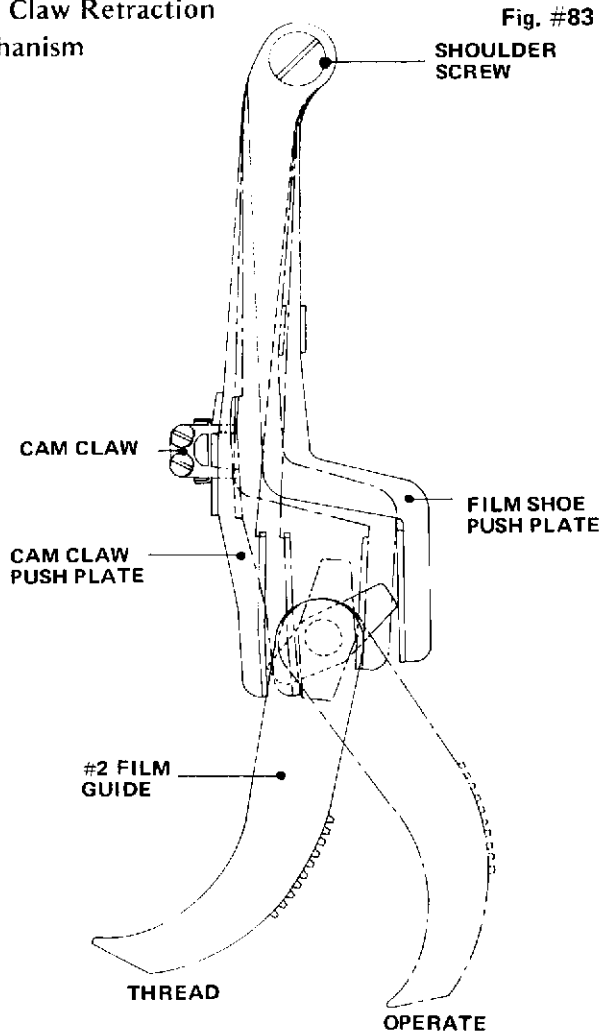

Rubber Pinch Roller &  
Main Interlocking Bracket

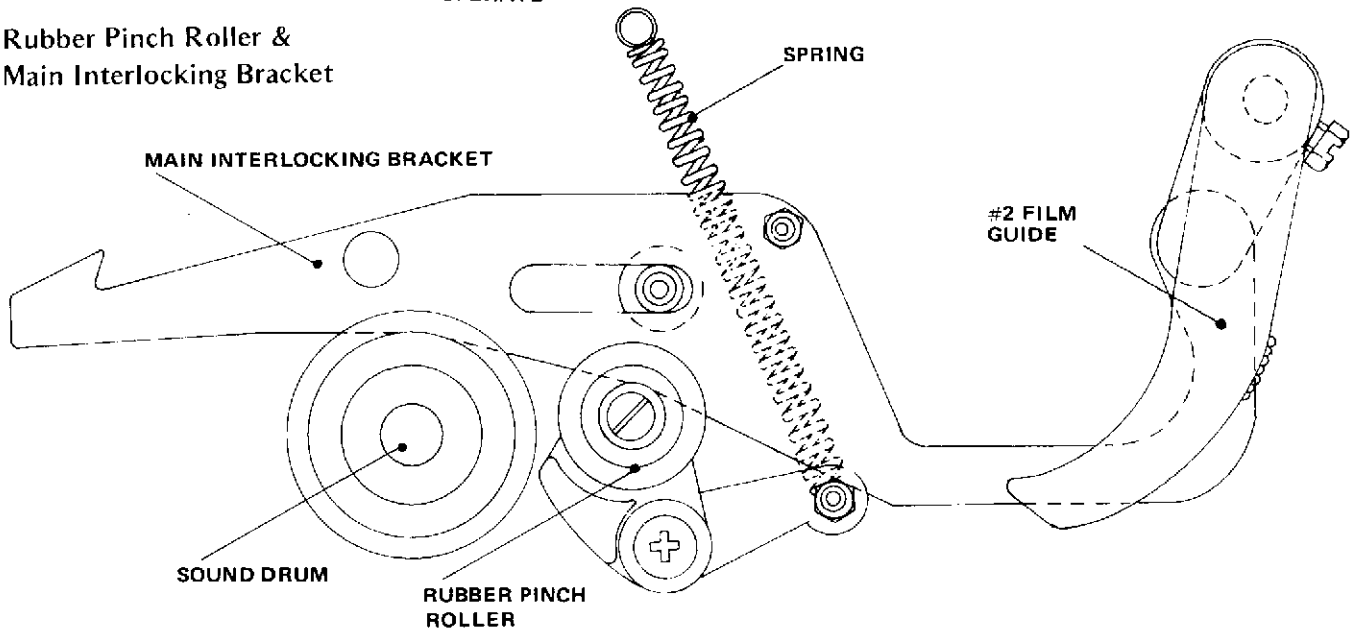

B. Adjustments:

1. #1 Sprocket Shoe Assembly:

The #1 sprocket shoe is spring loaded to keep the film in contact with the sprocket teeth, driving the film into the gate.

For manual thread, it may be opened when the lens holder is open. Check the shoe clearance using three layers of film in the following manner:

First insert one 5cm (2") strip of film into the film channel, advance the mechanism using the inching knob. When the first strip is fed through the film shoe, insert another strip on the first, continue to advance the inching knob. With two thicknesses of film, the shoe should not begin to open. Next, insert a third strip and advance the inching knob. This time the shoe should slightly open with three layers of film between the sprockets and the shoe.

Fig. #86

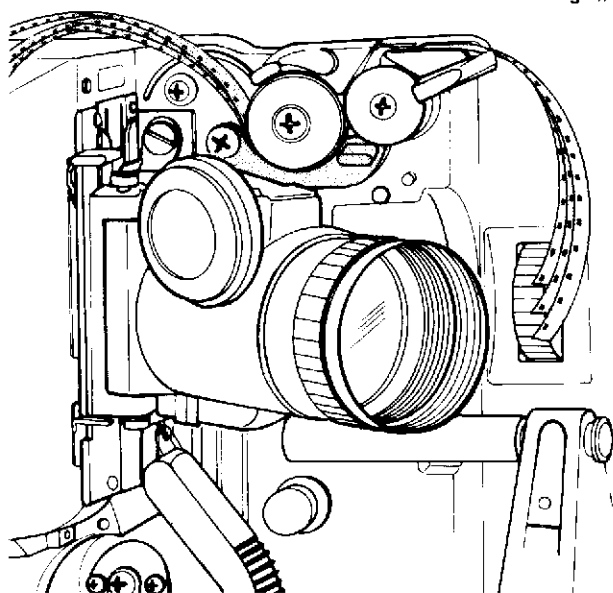

**NOTE:** A simple test film may be made by cementing three short strips of film together.

Fig. #87

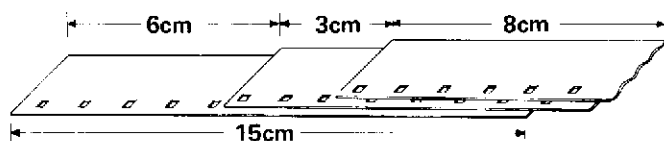

Under normal circumstances, the shoe does not require any adjustments, however, as the film

shoe wears, the clearance will become too great, requiring replacement. When a replacement is not available, the small protrusion which determines the clearance may be filed to the correct clearance.

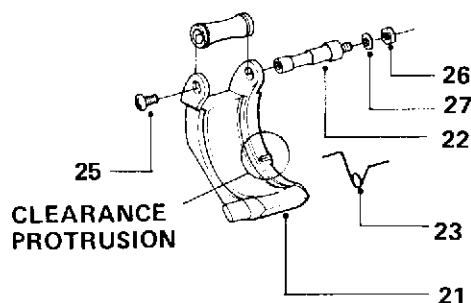

Fig. #88

Too little or no clearance will cause film wear or damage. Care should be taken when removing the shoe not to lose the "V" spring (23).

2. #1 Film Guide:

In the self-thread position, the #1 film guide (1, Fig. #80) is extended from the main casting, guiding the film from the #1 sprocket and shoe into the film gate. After the threading mechanism is released, the guide recedes away from the film path.

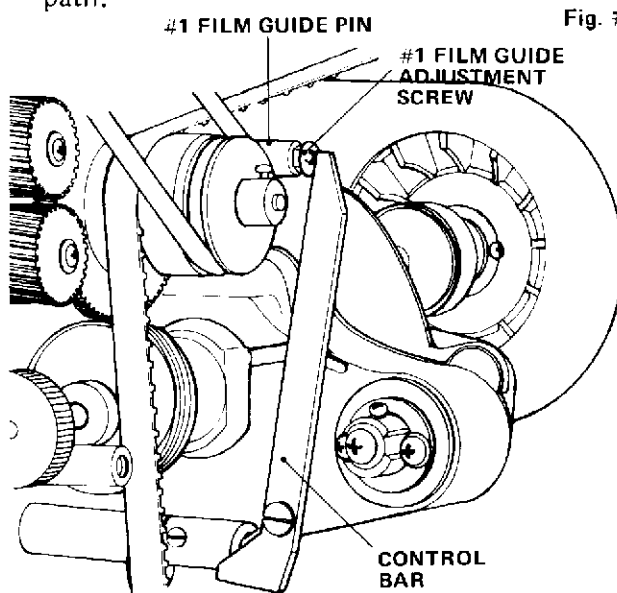

Fig. #89

The film guide travels approximately 20mm from operate to self-thread. This travel is not critical. There should be enough travel for the guide to retract away from the film in normal operation, and in self-thread extend to the width of the aperture plate. To adjust this travel, loosen or tighten the screw and jam nut. (See Fig. #89).



**NOTE:** The position of the cam tank may affect the position of the control bar which activates the #1 film guide. It is important that the control bar aligns with the #1 film guide.

**3. Retraction Of The Claw:**

When the #2 film guide (12) is set to self-thread, plate (7) pushes the claw away from the gate. The claw must be completely retracted, however, if it is pushed too far, the rear of the claw lever will interfere with the shutter blades. A loud click, click sound will be heard.

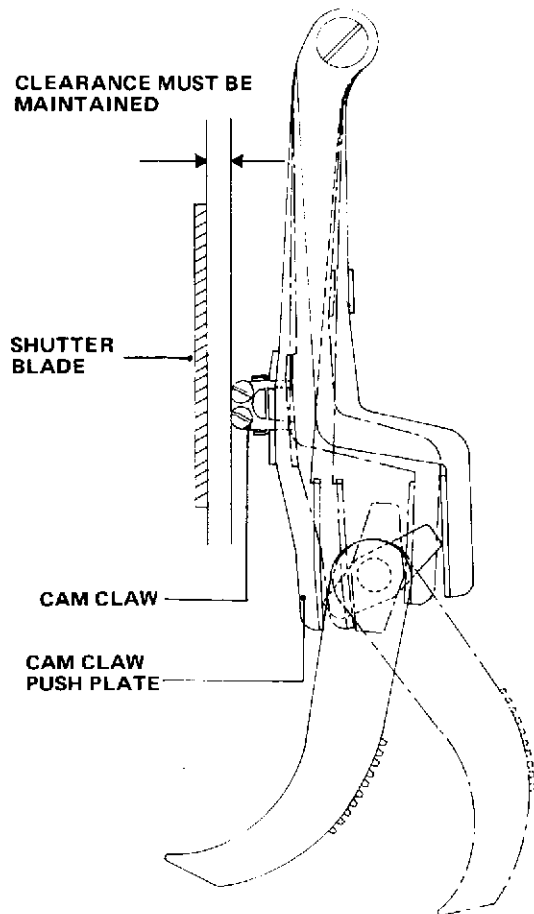

To adjust this clearance, it is necessary to slightly re-form the plate (7) decreasing or increasing the claw's retraction. In instances where the shutter blade has been bent, it may be necessary to re-form the shutter blade.

**4. #2 Film Guide:**

The #2 film guide acts as the self-threading mechanism setting lever. At the same time it forms the path for the lower loop. When the #2 film guide (12) is set, the cam bracket (13),

mounted to the pivot shaft of the #2 film guide, activates the interlocking bracket sub-assy. (14) engaging the release bracket assy. (32) locking the mechanism in self-thread position. To adjust, it may be necessary to reform the latching pin on the release bracket if the mechanism will not set to self-thread.

Fig. #90

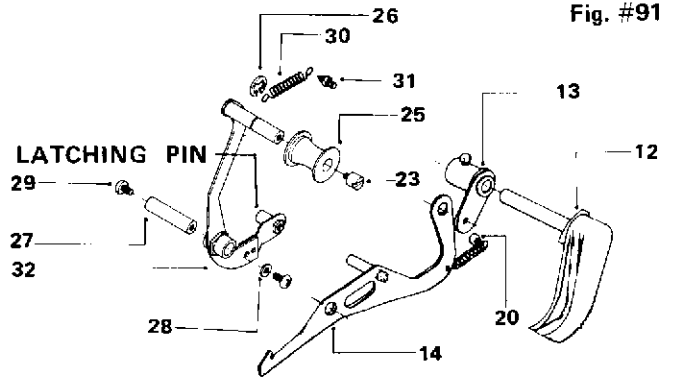
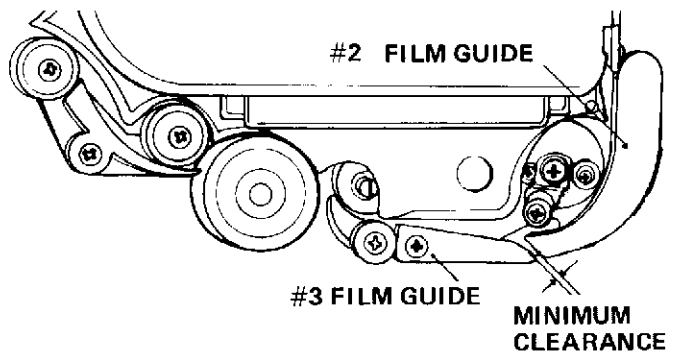

Fig. #91

A small amount of silicone grease on latching pin is required for smooth operation of the latching and release mechanism. It is important that the #2 and #3 film guide line up with a minimum of clearance. Too much clearance will allow the film to go under the #3 guide.

Fig. #92



**5. Sound Drum Rubber Pinch Roller:**

(Fig. #92, 93)

Fig. #93

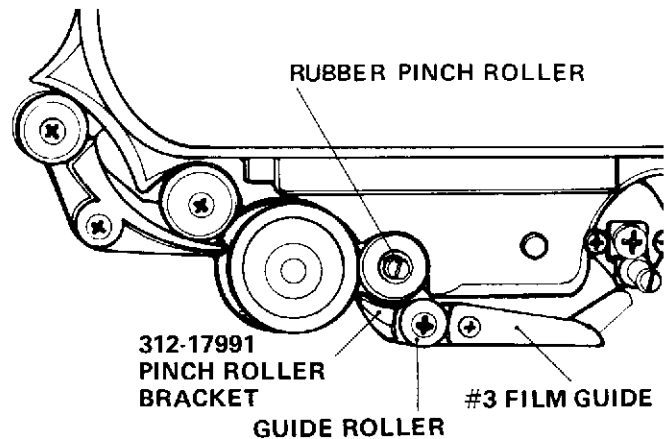

The sound drum rubber pinch roller is mounted on the #4 film guide (or pinch roller bracket 312-17991) which directs the film up and over the sound drum in the self-thread operation. This is accomplished by the interlocking bracket 312-17091 which depresses pin 312-17361, raising the rubber pinch roller away from the sound drum. When the self-thread mechanism is released, the rubber pinch roller rests firmly against the sound drum.

It is important that the rubber pinch roller be kept clean and that it rotates freely on the shaft. Remove the roller to clean and lubricate.

If the roller does not turn freely, it may restrict the film from advancing over the sound drum during self-threading. A dirty or restricted roller may also contribute to excess wow & flutter. To adjust the tensions of the pinch roller, push the #2 film guide to self-thread position.

- a. Insert two layers of 16mm film between the shoulders of the rubber pinch roller and lamp house casting.
- b. Locate pin 312-17361 so that it touches the bottom edge of the interlocking bracket.
- c. While pressing the rubber pinch roller toward the casting (with film between the roller shoulders and casting), tighten the screw that holds the pin bracket to the rubber roller shaft.

## 6. Tension Guide And Roller Assembly

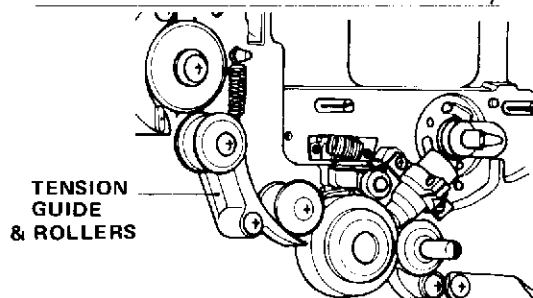

Fig. #95

The tension guide and roller assembly provides the dampening required between the #2 sprocket drive and the sound drum. When the guide rides midway between its limits, wow and flutter is minimized. During the self-thread operation, the tension guide (41) provides a path for the film to travel from the sound drum to the #2 sprocket drive.

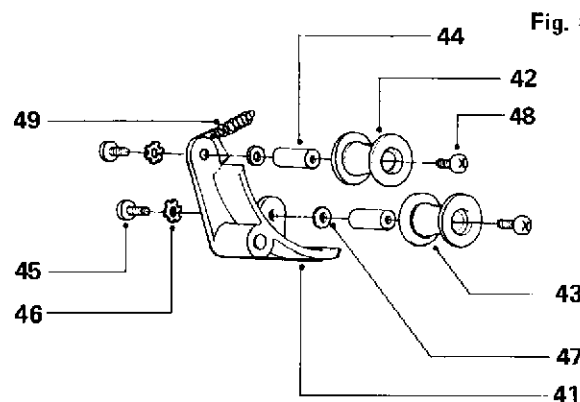
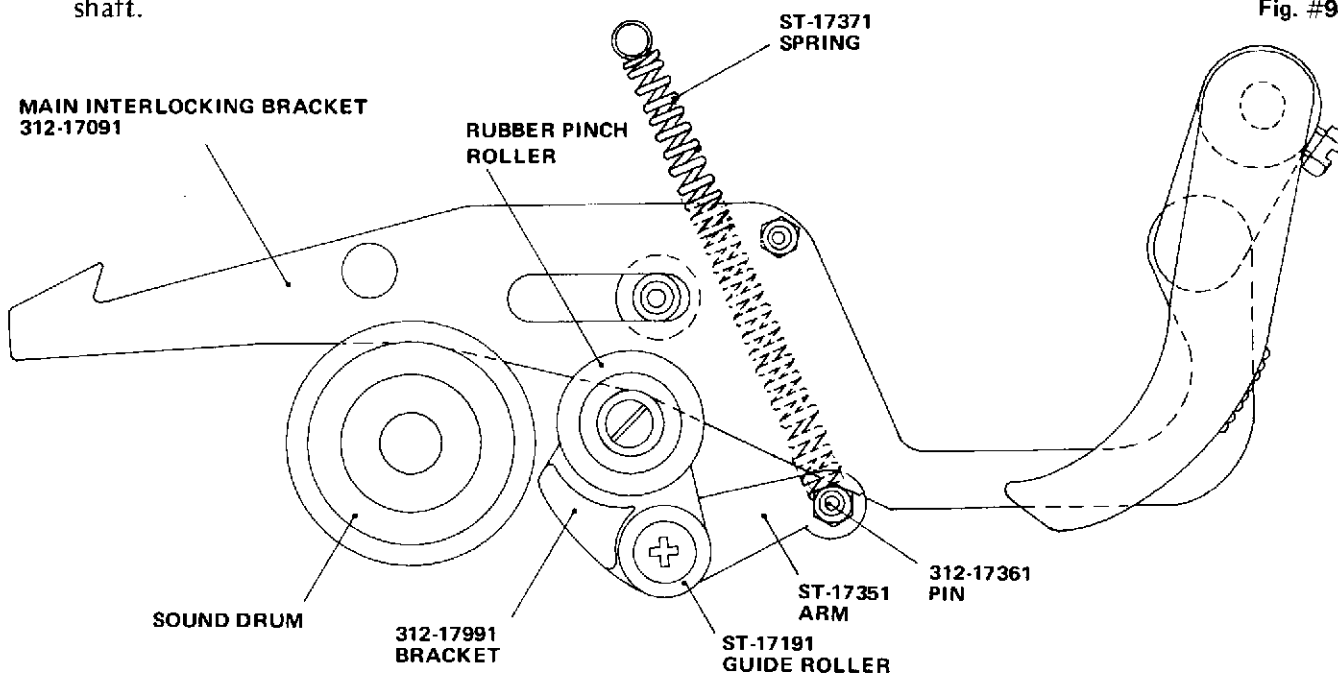

Fig. #96

Fig. #94



The rollers (42) and (43) must be clean and rotate freely on the shafts. The tension guide assembly (41) must pivot freely without binding. A rhythmic movement of the tension guide roller assembly indicates that a roller or the sound drum is binding or out of round. An out-of-round or bent #2 sprocket drive will also cause excessive tension guide movement. All of the above symptoms will result in abnormal wow and flutter. The tension of the guide and roller assembly is determined by spring (49) and can be adjusted by replacing the spring or slightly stretching or shortening the spring to achieve minimum wow and flutter. All nylon rollers should be cleaned with alcohol and lubricated sparingly with silicone oil.

7. #2 Sprocket And Shoe Assembly:

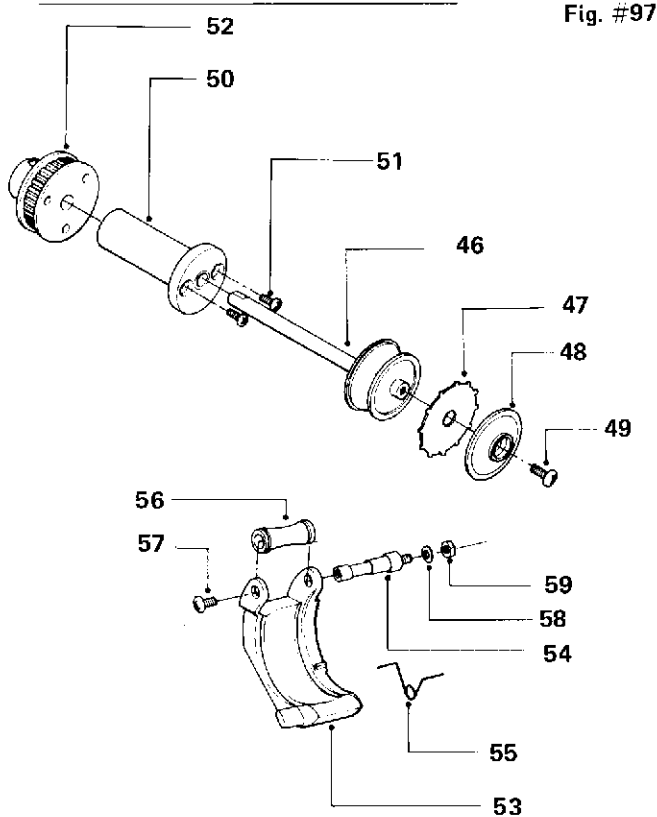

The drive consists of the sprocket cover (48), the sprocket teeth plate (47), the sprocket drum and shaft (46), the hub and bushing assembly (50), and the drive gear (52). There must be no end play of the sprocket drum shaft in the bushing. Small fiber washers (G4-070120, G8-070120) are installed to achieve this condition. The sprocket plate (47) must be in good condition, with no defective sprocket teeth,

otherwise it must be replaced. For correct timing adjustment of the #2 sprocket drive assembly, refer to the loop setter section. (Sec. 5-4)

The #2 sprocket shoe keeps the film in contact with the sprocket teeth. The shoe should always remain closed on all self-threading projectors. The shoe tension is maintained by the "V" spring (55). It is important to note that the #2 sprocket shoe spring is stronger than the #1 sprocket shoe spring. The proper clearance between the shoe (53) and the sprocket drum (46) is very important. To test this clearance, take short piece of film and feed it into the #2 sprocket using the inching knob to advance the projector's mechanism. Add another strip of film on top of the first and advance the projector. With a double thickness of film the film shoe should not begin to open. Add a third layer of film and advance the projector. This time the film shoe should begin to open, indicating that the shoe clearance is correct.

**NOTE:** A simple test film may be made by cementing three short strips of film together. (See Sec. 5-5-B-1, Note)

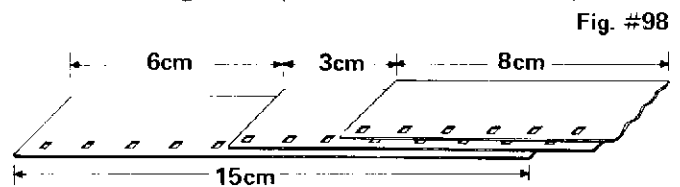

The proper film shoe clearance is determined by a small protrusion molded on the shoe which indexes the shoe against the bushing hub (50).

Fig. #99

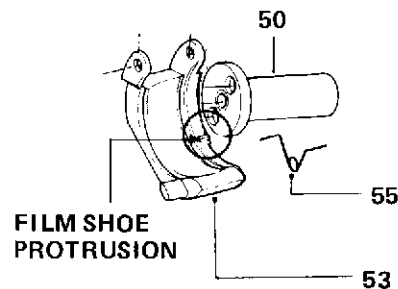

As the shoe wears it may be necessary to replace it to obtain the correct clearance. In some cases the shoe clearance may be reduced by filing the protrusion.

**CAUTION:** Too close a clearance will result in poor threading or possible film damage.

### 5-6: REWIND MECHANISM

#### A. Description (Fig. #100, 101)

The rewind is accomplished by threading the film from the take-up reel to the supply reel, and engaging the rewind gears by pressing down on the rewind lever, then switching the projector to the forward/rewind position.

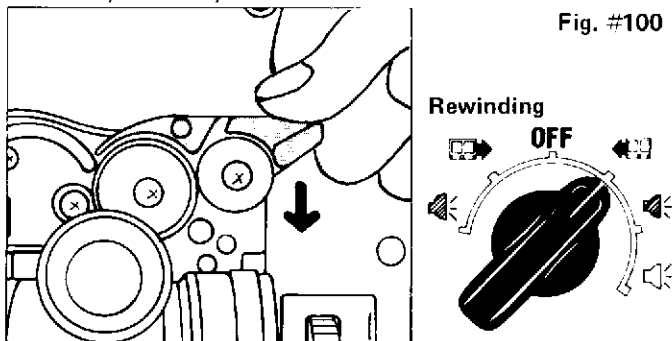

Fig. #100

When the rewind lever (24) is engaged, the eccentric shaft (25) releases the pressure to the cap screw (38) causing the rewind gears (45) and (49) to mesh, thus positively driving the supply arm.

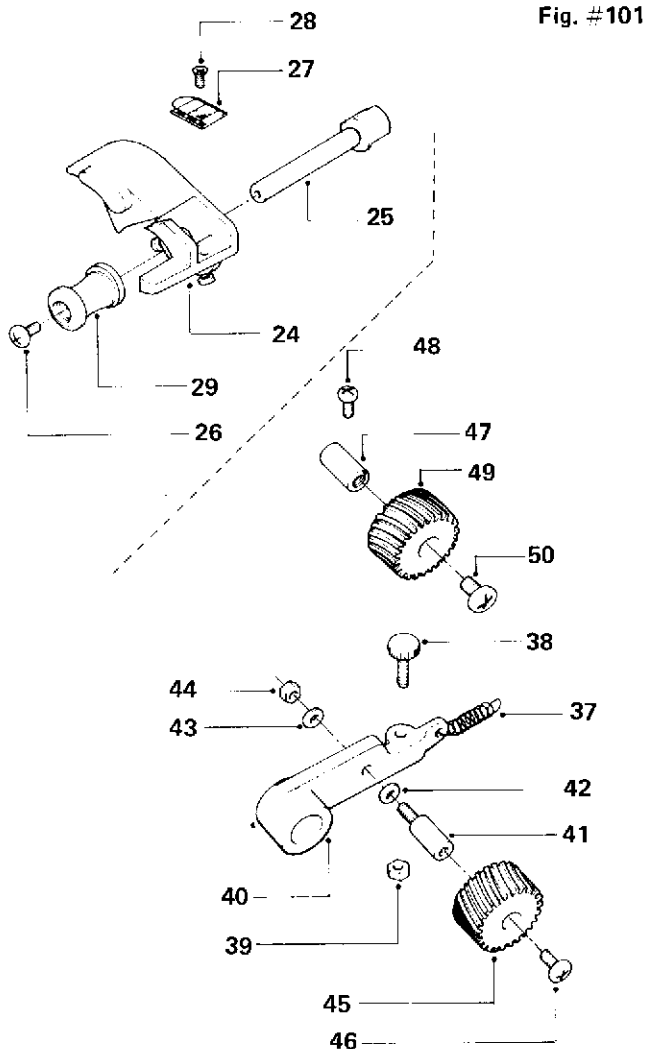
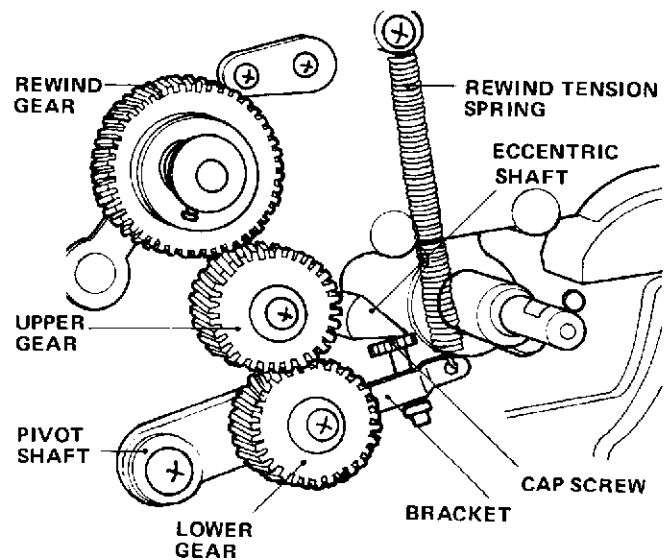

Fig. #101

#### B. Adjustments

The amount of gear lash is determined by the cap screw (38). The tension of the rewind lever is controlled by the spring (37). The rewind gears (45) and (49) must mesh completely with only a slight amount of lash to avoid unnecessary wear. It is important that all the gears roll freely with a slight amount of silicone oil on the shaft. The rewind bracket assembly should also operate freely on its pivot shaft (33).

Fig. #102



### 5-7: SOUND DRUM AND FLYWHEEL

#### A. Description

The sound drum and flywheel assembly's main function is to stabilize the film, allowing the sound optics or magnetic head to read the sound tracks with a minimum of speed variations. The sound drum, shaft, bearing and flywheel are precision machined and balanced to maintain a consistent linear film speed. Care should be used when disassembling or re-assembling these precision parts.

The sound drum shaft (5) is seated in two precision ball bearings (3) which are sealed and factory lubricated. The ball bearings are lightly press fitted into the sound hub casting (2). The shaft is secured in place by a set collar (6). With the fiber washer in place, with no end play in the sound drum shaft, it must rotate freely and not bind. Any binding or imperfections in the ball bearing will result in excessive wow & flutter. In the forward direction, the sound drum shaft (5) is driven by the tension of the film. The flywheel is free to slip on the sound drum shaft during the initial start up of the projector to prevent any possible film damage. In the reverse direction, the set collar (6) is driven by the reverse rubber roller, allowing the film to be transported smoothly across the sound drum in the reverse direction. (Fig. #103, 104, 105)

**B. Adjustments**

The drive torque to the flywheel is determined by the tension of the plate spring (8). The normal torque should be between 20 – 25 grams. To check this, use a gram scale and attach a string to

the flywheel with adhesive tape. With no film in the projector, switch to reverse while holding the gram scale attached to the string. To adjust this torque, remove the plate spring and bend to obtain the correct tension. A badly formed spring should be replaced.

(Fig. #106)

Fig. #104

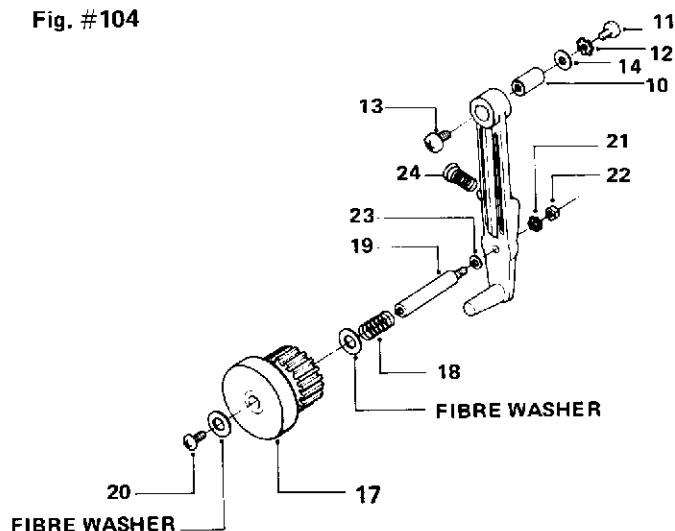

Fig. #105

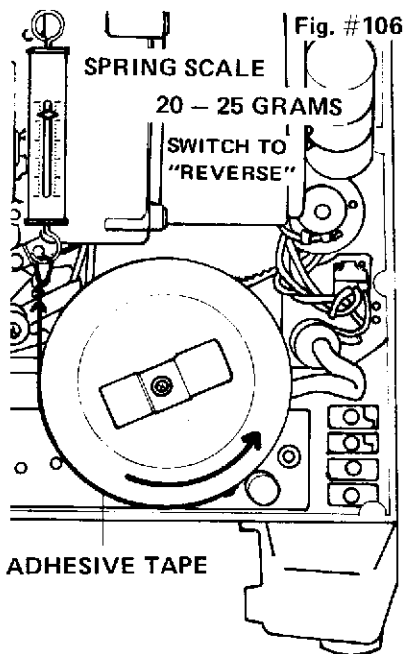
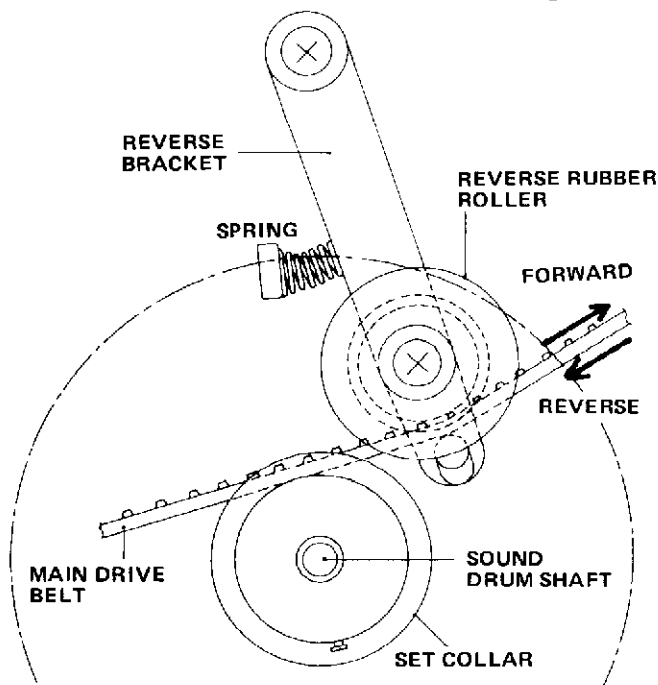
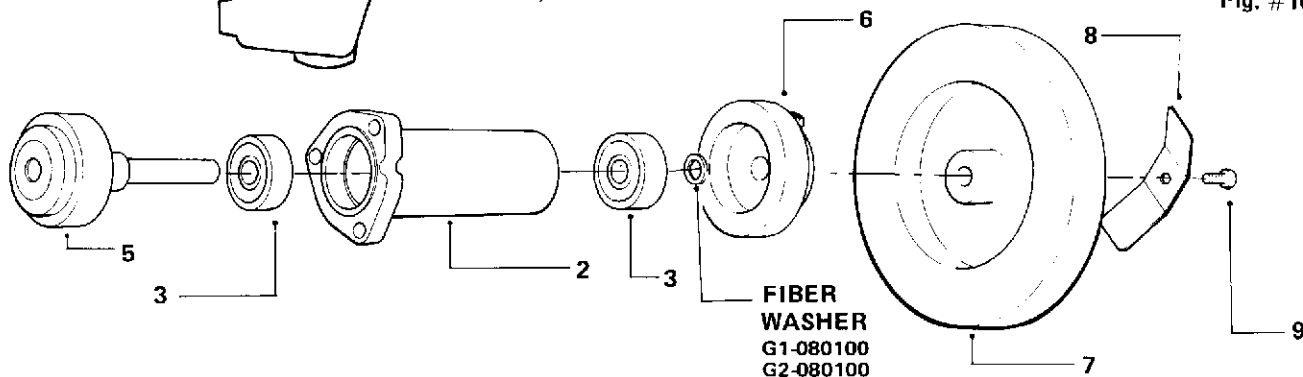

Fig. #103



## 314-6: SOUND PICK-UP SYSTEM

### 6-1: OPTICAL SOUND FOCUSING PROCEDURE

#### A. Description

Models NST-0, NT-0, NST-1 and NT-1 are optical sound playback only. Models NST-2 & NT-2 are both optical and magnetic playback and NST-3 & NT-3 are optical playback with magnetic playback and record. The optical pick-up system resembles a small projector within a projector, consisting of a light source, a lens, an image, and a screen or target.

Fig. #107

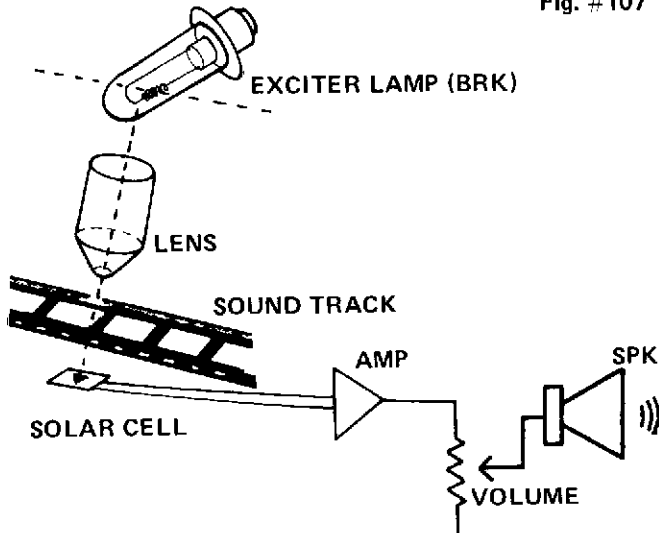

The light from the exciter lamp is focused through the sound track imaged onto the (target) solar cell where varied light intensity is converted into minute electrical voltage changes that are amplified and converted into acoustical variation or sound which directly relate to the photographic variation recorded on the film.

#### B. Sound Focus Alignment Procedure

##### 1: Tools and Equipment Required

- a. Screw driver set (Iso)
- b. Sound lens adjustment tool (Tool No. 320-02T. Fig. #108, See note below)
- c. SMPTE sound focus test film 7000Hz
- d. SMPTE buzz track test film
- e. AC VTVM (audio range) and or
- f. Oscilloscope
- g. 8 ohm 30 watt dummy load resistor
- h. External speaker (front cover)

Fig. #108

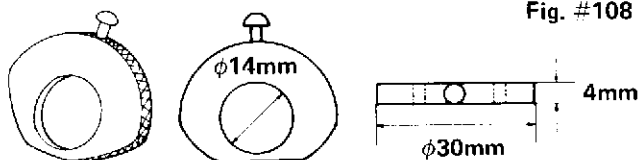

SOUND LENS ADJUSTMENT TOOL

##### 2. Set-up Procedure

- a. Open the lamp house door and remove the exciter lamp cover.
- b. Remove the lamp house door with frame casting to obtain access to the sound lens.

Fig. #109

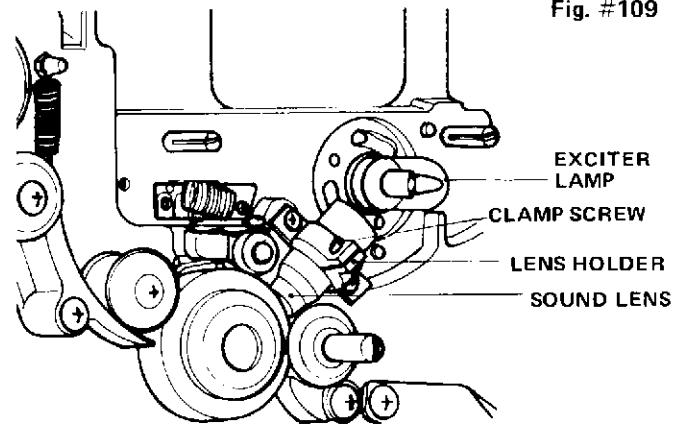

- c. Insert the tool No. 320-02T onto the larger barrel of the sound lens and tighten the set screw on the tool.

Fig. #110

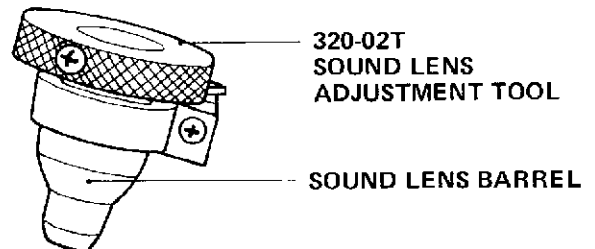

**NOTE:** This adjustment may also be performed by adjusting the sound lens with your fingers, if the tool is not available.

##### 3. Sound Focusing Adjustment Procedure

- a. Connect the dummy load resistor to the speaker output jack.
- b. Thread the 7000Hz SMPTE test film loop with the emulsion side towards the film shoe.
- c. Connect either an AC VTVM (20 volt range) or an Oscilloscope across the dummy load resistor. (Fig. #113)

**NOTE:** When using instruments with a grounded shield input, avoid a ground loop condition by not connecting the shield at the load resistor.

- d. Turn the projector's function switch to forward.

e. Set the treble control to the Max. position and the bass to the Minimum.

Loosen the sound focus lens clamp screw slightly to allow a rotation of the lens.

f. Turn on the volume control towards maximum and observe the AC VTVM or the Oscilloscope.

(1). With the AC VTVM connected, observe the meter while slowly moving the lens up or down and slightly rotating until the maximum voltage reading is achieved. Clamp the sound lens and this completes the sound focusing alignment.

(2). With the Oscilloscope connected across the dummy load resistor a more precise alignment can be achieved. Observe the 7000Hz sine wave at both full volume and a lower volume at the same time adjusting the rotation and up or down position of the sound lens, for maximum P-P voltage of the sine wave. A clean undistorted sine wave should be observed as shown in Fig. #111 corresponding to the volume and tone control positions as indicated.

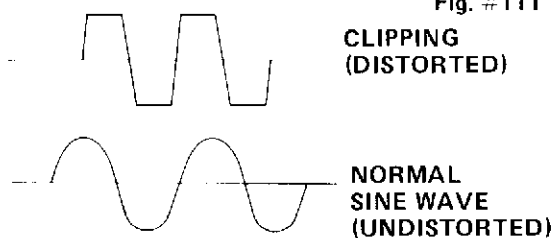

Fig. #111

#### 4. Buzz Track Adjustment Procedure

a. Connect the projector to the test set-up as Fig. #113.

b. Load an SMPTE buzz track test film loop with the emulsion side towards the film shoe.

c. Turn the function control switch to the Forward position.

d. Turn the amplifier volume and tone controls to maximum (clockwise) and listen for a clear 1000Hz tone.

e. Sound lens holder is mounted on two pins (4) & (5) which slide into holes of the frame casting. Loosen the upper screw (8) to allow adjustment.

Adjust the buzz track by slowly sliding out the sound lens holder (1), until the 1000Hz tone is inaudible and a 300Hz tone becomes audible.

f. Then slowly slide in the sound lens holder until neither the 300Hz or the 1000Hz tone is audible, indicating correct buzz track alignment. Tighten the upper lock screw (8).

g. Re-check the 7000Hz sound focus alignment.

h. Remove the exciter lamp. Remove the round lens adjustment tool. Re-install the exciter lamp and wipe off any fingerprints.

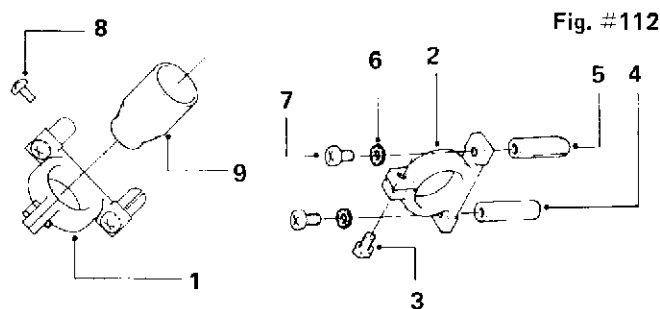

Fig. #112

g. This completes the Sound Focus adjustment. Clamp the sound lens clamp screw and test with a good sound track film.

#### TYPICAL TEST SET-UP

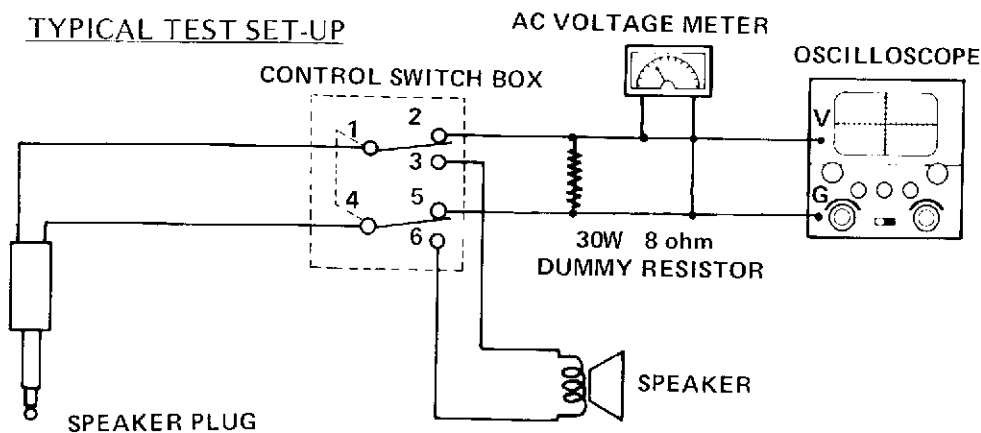

Fig. #113

## 6-2: MAGNETIC SOUND PLAYBACK SYSTEM

### A. Description

In addition to the standard optical sound playback, models NST-2 & NT-2 include magnetic soundtrack playback and models NST-3 & NT-3 include both magnetic playback and record. The Mag/Opt selector switch operates a lever which positions the magnetic head against the film's sound track, at the same time the appropriate electrical connections are made.

In the record models the lock-out button prevents the selector from being accidentally switched to record. A special combination record/play and erase head is used for simplicity and a minimum of adjustment. Both the record level and playback volume is accomplished with the volume control and equalization is provided by the bass and treble controls. The small meter provides level monitoring during record.

Since the record and playback is accomplished using only one head the alignment procedure for the NST-2 & NT-2 and NST-3 & NT-3 models are the same.

HUM COIL (314-40301)  
NT: S/N 18475 AND UP  
NST: S/N 10489 AND UP

Fig. #114

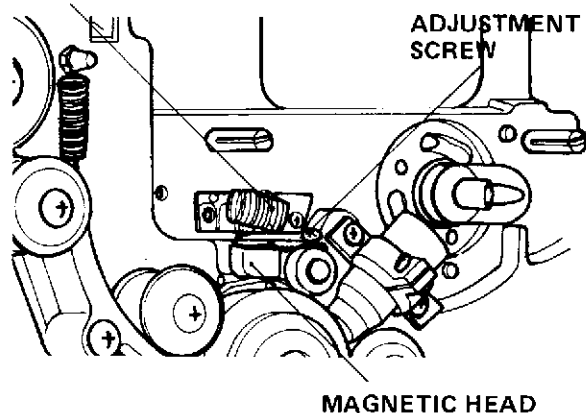

### B. Magnetic Head Alignment Procedure

#### 1. Tools and Equipment Required

- Screw driver set (Iso)
- Magnetic Azimuth 7000Hz alignment SMPTE test film loop.
- Pliers
- AC VTVM (Audio Range) and or
- Oscilloscope
- 8 ohm 30 watt dummy load resistor
- External speaker (front cover)

#### 2. Set-up Procedure

Fig. #115

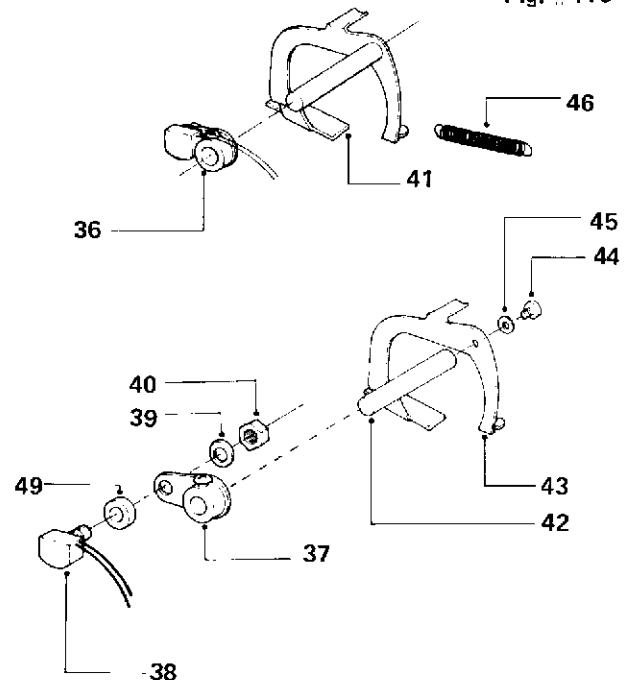

- Open the lamp house door.
- Remove the frame casting to obtain access to the magnetic head.
- Thread a magnetic azimuth alignment test film.
- Set the Mag/Opt switch to the Mag Play position.
- Connect the projector to a dummy load resistor and test set-up. (See Sec. 6-1-B-3. Fig. #113)
- Turn on the projector and amplifier.
- Set the treble control to the Max. position and the bass at the Minimum.
- Adjust the volume control to just before the amplifier clips.
- Carefully loosen the adjustment screw which allows the head to be positioned on the mag. track.

To adjust, hold the mag. head gently with the pliers and slightly turn the head clockwise or counter-clockwise until the correct head position on the mag. track is obtained. Then, align the head core slit right on the mag. track by slightly bending, if necessary, the head mounting arm to the right or left.

When the correct head position and the angle are obtained, a maximum voltage reading will be indicated on the AC VTVM, while at



the same time the sine wave observed on the oscilloscope is not clipped.

- j. With the Oscilloscope connected across the load resistor, observe that the 7000Hz sine wave is not clipped or unusually distorted at both low and high volume. If necessary, make additional minor adjustments.
- k. When a clean, undistorted sine wave at maximum voltage is achieved, the alignment is complete.
- l. Secure the adjustment screw, and apply a drop of lock-tight sealer.
- m. Check the sound with a well recorded source track.
- n. On NST & NT-3 models, make a recording and re-check the playback.

NOTE (1): Should the record not function, refer to the amplifier section 314-4-2 and check amplifier or bias oscillator functions.

NOTE (2): Excessive audio hum may occur by installing a motor without its magnetic shield.

314-50701 AMP MODULE COMPLETE  
FOR -2 TYPE MAG REAR MODEL

314-50801 AMP MODULE COMPLETE  
FOR -3 TYPE MAG RECORD MODEL  
COMPLETE WITH 314-50811 OSCILLATOR  
P.C. BOARD ASSY.

### 314-7: LAMP CIRCUIT

#### 7-1: LAMP CIRCUIT

##### A. Description

The "N" series projector is designed with a 24 volt AC Quartz Halogen 250 watt ELC lamp. A 200 watt EJL lamp may also be used with some reduction in light output. The function switch provides either a high or low lamp voltage selection to extend the lamp life.

##### B. Replacement And Alignment

1. Disconnect AC power cord.
2. Open the lamp house door.
3. Push the lamp ejection lever to the left and the lamp will come out.

##### CAUTION: LAMP MAY BE HOT

4. When replacing lamp be sure that it snaps into the lamp socket properly and that heat shield and lamp house cover are re-installed.
5. For maximum, even illumination, it may be necessary to adjust the lamp position to allow for slight variations in lamps. Turn knurled nut for horizontal adjustment.

OFF ○ : ALL OFF

◀◻ : SW#1 ON

◀◻◻ : SW#1 & 4 ON

◀◻◻◻ : SW#1, 4 & 5 ON

◻◻◻▶ : SW#1, 2 & 3 ON

◀◻◻◻◻ (REV) : SW#1, 2, 3 & 4 ON

#### FUNCTION ROTARY SWITCH

Fig. #116.

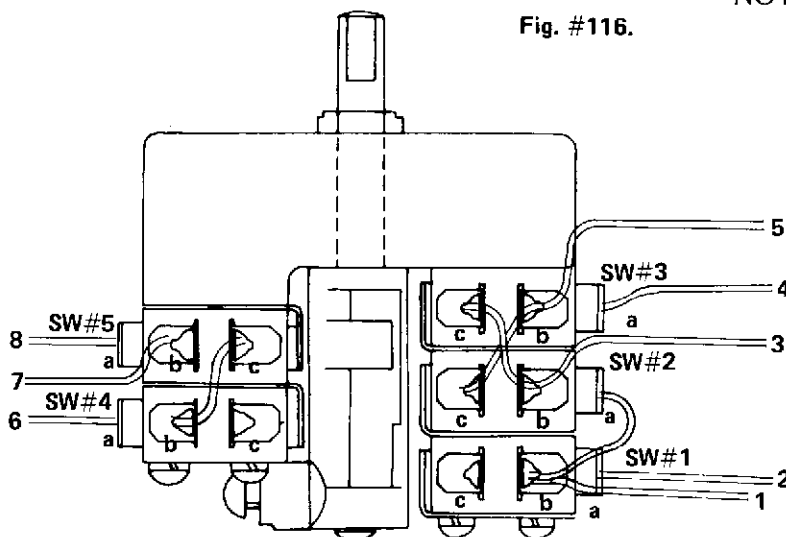

a: Common  
b: Normal open  
c: Normal close

### 314-8: ELECTRICAL SYSTEM

#### 8-1: ELECTRICAL SYSTEM

##### A. Function Switch

Micro Switch #	Type of Switch & Part #	Function
SW#1	V-15-1A3M 312-60051	Forward
SW#2	V-15-1A3M 312-60051	Reverse
SW#3	V-15-1A3M 312-60051	Reverse
SW#4	V-15-1A3M 312-60051	Lamp Low
SW#5	V-15-1A3M 312-60051	Lamp High

Wire #	Color	Type	Connected to:
#1	Brown	AWG #20 (*)	Motor 6 Pin Connector #1
#2	Brown	AWG #20	AC Terminal #1 (**)
#3	White	AWG #20	Motor 6 Pin Connector #2
#4	Grey	AWG #20	Motor 6 Pin Connector #5
#5	Blue	AWG #20	Motor 6 Pin Connector #4
#6	Blue	AWG #18	Transformer 3 Pin Connector #2
#7	Red	AWG #18	Transformer 3 Pin Connector #1
#8	Red	AWG #18	Halogen Lamp

\*NOTE (1): For 120V UL & CSA only, wire #1 is AWG #18.

\*\*NOTE (2): For 220V SCAN type, wire #2 is connected to AC Terminal #2

NOTE (3): For 220V SEMKO type see page 78.

- ##### B. Electrical Circuit Diagrams
- (Electrical Schematic)  
(Electrical Block Diagram)  
(See the end of this manual)

## **314—9: SERVICE UPDATES AND MODIFICATIONS**

EIKI "N"-Series has had several modifications. All the important modifications are included and discussed in this manual.

Further modification after the issue of this manual will be covered by SERVICE UPDATES, which are recommended to be filed in this section.