

**When the show must go on.**

EIKI

P/N: 4421

16MM SOUND PROJECTOR

# **SNT & ENT SERIES SERVICE MANUAL**

APR. 1986

**EIKI INDUSTRIAL CO., LTD.**

4-12 Manzai-cho Kita-ku  
OSAKA, JAPAN, Phone:(06)311-9479

**EIKI INTERNATIONAL, INC**

27882 Camino Capistrano,  
P.O. BOX 30000, Laguna Niguel,  
CA 92677-8000, Phone:(714)831-2511

Authorized EIKI Distributor or Dealer:

# TABLE OF CONTENTS

|              | Title  | Page |
|--------------|--|------|
| INTRODUCTION |  |      |
| 315-1        | GENERAL DESCRIPTION  |      |
| 1-1          | Physical Dimensions . . . . .  | 2    |
| 1-2          | Specifications . . . . .   | 3    |
| 315-2        | PRINCIPLES OF OPERATIONS   |      |
| 2-1          | Mechanical System . . . . .  | 4    |
| 2-2          | Electrical System . . . . .  | 5    |
| 2-3          | Sound System . . . . .   | 5    |
| 315-3        | SERVICE PROCEDURES   |      |
| 3-1          | Precautions . . . . .  | 6    |
| 3-2          | Tools And Test Equipment . . . . .   | 6    |
| 3-3          | Lubricants And Lubrication Charts . . . . .                                    | 7    |
| 3-4          | Troubleshooting Hints . . . . .  | 9    |
| 3-5          | Troubleshooting Chart . . . . .  | 11   |
| 315-4        | MODULE REMOVAL AND INSTALLATION  |      |
| 4-1          | Cam Tank Module . . . . .  | 23   |
| 4-2          | Amplifier Module . . . . .   | 23   |
| 4-3          | Motor Module . . . . .   | 24   |
| 4-4          | Transformer Module . . . . .   | 24   |
| 4-5          | Film Shoe And Bracket Assy., Lens Holder Assy.,<br>And Film Gate Assy. . . . . | 24   |
| 315-5        | MODULE REPAIR AND ADJUSTMENTS  |      |
| 5-1          | Cam Tank Module  |      |
| A.           | Specifications . . . . .   | 26   |
| B.           | Disassembly . . . . .  | 26   |
| C.           | Re-Assembly . . . . .  | 27   |
| D.           | Adjustments . . . . .  | 27   |
| 1.           | Claw Protrusion . . . . .  | 27   |
| 2.           | Claw Position And Framing . . . . .  | 28   |
| E.           | Replacing The Claw . . . . .   | 29   |
| F.           | Changing Shutter Blades . . . . .  | 31   |
| G.           | Still-Run Clutch . . . . .   | 32   |
| 1.           | Description . . . . .  | 32   |
| 2.           | Adjustment . . . . .   | 34   |
| 5-2          | Amplifier Module   |      |
| A.           | Specifications . . . . .   | 36   |
| B.           | Power Supply Circuit . . . . .   | 36   |
| C.           | Audio Amplifier Circuit . . . . .  | 36   |
| D.           | Circuit Diagrams . . . . .   | 38   |
| 5-3          | Motor Module   |      |
| A.           | Specifications . . . . .   | 42   |
| B.           | Motor Circuit Diagram . . . . .  | 42   |
| C.           | Silent Film Operation And 50 ↔ 60Hz Conversion . . . . .                       | 43   |

|         | <b>Title</b>  | <b>Page</b> |
|---------|---|-------------|
| 5-4:    | Transformer Module . . . . .                            | 44          |
| 5-5:    | Film Sensor System                                      |             |
|         | A. Description . . . . .                                | 44          |
|         | B. Adjustment . . . . .                                 | 44          |
| 5-6:    | Film Gate Assy.   |             |
|         | A. Description . . . . .                                | 46          |
|         | B. Adjustments  |             |
|         | 1. Tension of the Slide Pressure Spring . . . . .       | 46          |
|         | 2. Outer Guide Rail Position . . . . .                  | 46          |
| 5-7:    | Film Shoe And Bracket Assy.                             |             |
|         | A. Description . . . . .                                | 47          |
|         | B. Adjustments  |             |
|         | 1. Uneven Focus . . . . .                               | 47          |
|         | 2. Film Shoe Pressure . . . . .                         | 48          |
|         | 3. Film Shoe Position . . . . .                         | 48          |
| 5-8:    | Film Guard (ENT only)                                   |             |
|         | A. Description . . . . .                                | 49          |
|         | B. Adjustment . . . . .                                 | 49          |
| 315-6 : | <b>GENERAL MECHANICAL SERVICING AND<br/>ADJUSTMENTS</b> |             |
| 6-1:    | Take-up Arm   |             |
|         | A. Description . . . . .                                | 50          |
|         | B. Adjustment . . . . .                                 | 51          |
| 6-2:    | Supply Arm  |             |
|         | A. Description . . . . .                                | 52          |
|         | B. Adjustments . . . . .                                | 52          |
| 6-3:    | Lower Loop Setter System                                |             |
|         | A. Description . . . . .                                | 53          |
|         | B. Adjustments . . . . .                                | 53          |
| 6-4:    | Self-threading Mechanism                                |             |
|         | A. Description . . . . .                                | 55          |
|         | B. Adjustments  |             |
|         | 1. #1 Sprocket shoe assy. . . . .                       | 56          |
|         | 2. #1 Film guide . . . . .                              | 56          |
|         | 3. #2 Film guide . . . . .                              | 57          |
|         | 4. Lower loop forming mechanism . . . . .               | 57          |
|         | 5. Sound drum pinch roller . . . . .                    | 58          |
|         | 6. Tension guide & roller assy. . . . .                 | 59          |
|         | 7. Tension arm assy. . . . .                            | 59          |
|         | 8. Release roller arm assy. . . . .                     | 60          |
|         | 9. #2 Sprocket and shoe assy. . . . .                   | 60          |

|         | Title  | Page |
|---------|--|------|
| 6-5:    | Rewind System                                    |      |
|         | A. Description . . . . .                         | 62   |
|         | B. Adjustments                                   |      |
|         | 1. Rewind mechanism . . . . .                    | 63   |
|         | 2. Rewind spring adjustment . . . . .            | 63   |
|         | 3. Film solenoid . . . . .                       | 63   |
| 6-6:    | Sound Drum And Flywheel                          |      |
|         | A. Description . . . . .                         | 64   |
|         | B. Adjustments . . . . .                         | 64   |
| 6-7:    | Reverse Projection                               |      |
|         | A. Description . . . . .                         | 65   |
|         | B. Adjustment . . . . .                          | 65   |
| 315-7 : | <b>SOUND PICK-UP SYSTEM</b>                      |      |
| 7-1:    | Optical Sound Focusing Procedure                 |      |
|         | A. Description . . . . .                         | 67   |
|         | B. Alignment . . . . .                           | 67   |
|         | 1. Tools and equipment . . . . .                 | 67   |
|         | 2. Set-up procedure . . . . .                    | 67   |
|         | 3. Sound focus adjustment . . . . .              | 69   |
|         | 4. Buzz track adjustment . . . . .               | 69   |
| 7-2:    | Magnetic Sound Playback System                   |      |
|         | A. Description . . . . .                         | 70   |
|         | B. Alignment . . . . .                           | 70   |
|         | 1. Tools and equipment . . . . .                 | 70   |
|         | 2. Set-up procedure . . . . .                    | 70   |
|         | C. Magnetic Head Lift . . . . .                  | 71   |
| 315-8 : | <b>LAMP CIRCUIT</b>                              |      |
| 8-1:    | Lamp Circuit                                     |      |
|         | A. Description . . . . .                         | 72   |
|         | B. Replacement And Alignment . . . . .           | 72   |
| 315-9 : | <b>ELECTRICAL SYSTEM</b>                         |      |
| 9-1:    | Electrical System                                |      |
|         | A. Function Rotary Switch (SSL-Series) . . . . . | 73   |
| 9-2:    | FNT Electronic Control System                    |      |
|         | A. Description . . . . .                         | 74   |
|         | B. Trouble Shooting Chart . . . . .              | 75   |

## INTRODUCTION

1. This Service Manual provides the necessary information for the repair, adjustment, and maintenance of EIKI's Slim Line Series projectors, models SNT-0, 1, 2, 3 and ENT-0, 1, 2, 3.
2. This service manual contains some part numbers for convenience in identification only. When ordering replacement parts, refer to SNT/ENT replacement parts list.
3. EIKI SNT/ENT projectors may in the future be improved or modified. Modifications made after the issue of this manual will be covered by Service Updates.
4. A copy of all of the pertinent diagrams are attached at the end of this manual.
5. CAUTION! Care must be exercised to avoid electrical shock while servicing the projector.

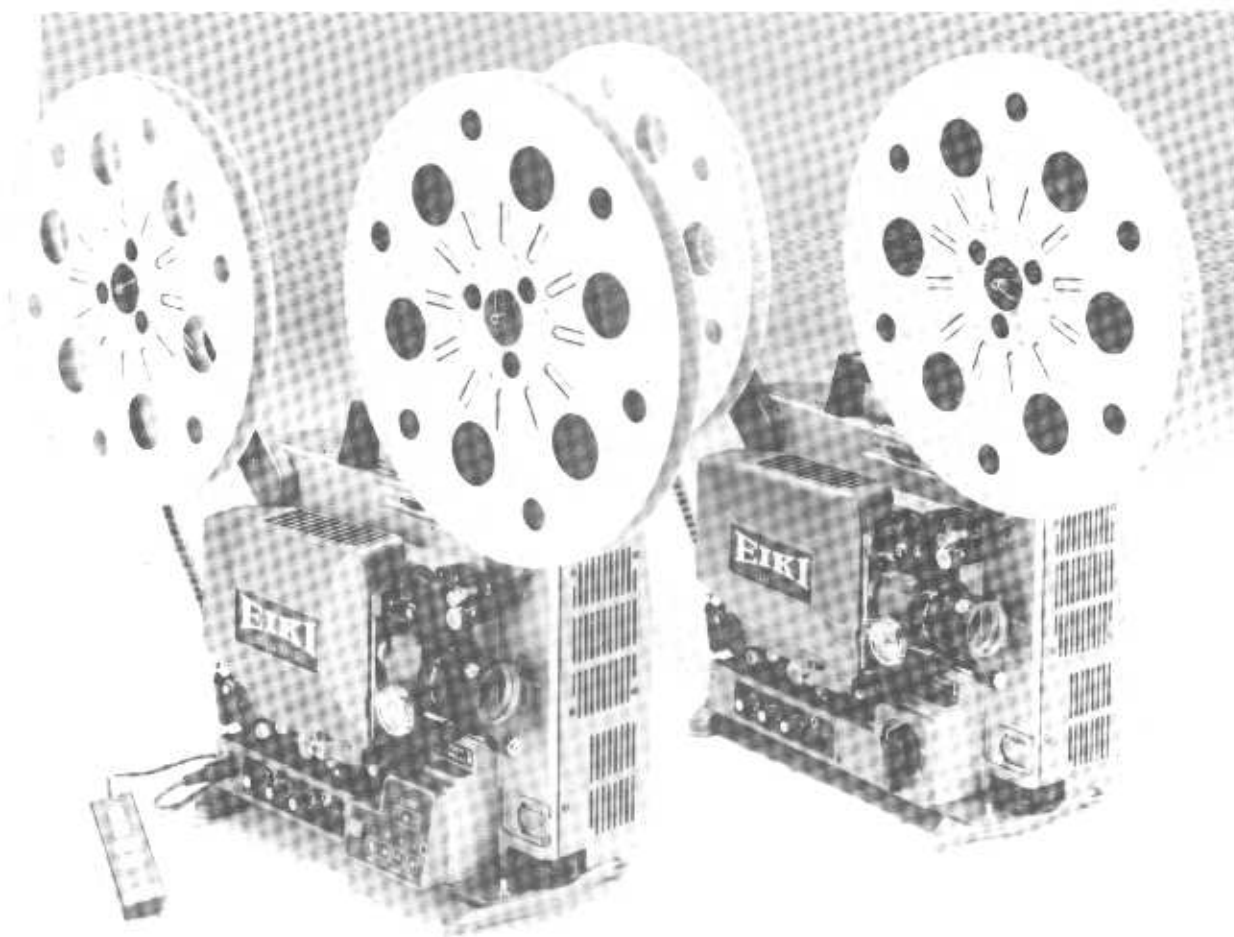

ENT-Series

SNT-Series

# 315-1: GENERAL DESCRIPTION

The Eiki Slim Line Self-threading series of portable halogen lamp projectors may be divided into two model groups;

- \* ENT, electronic touch button control self-threading projectors with built in remote control functions.
- \* SNT, conventional manual rotating function control with a 250 watt low voltage halogen lamp.

This manual will cover the mechanical functions of both groups together as they are very similar. In the electrical section each model group will be treated separately.

## 1-1 : PHYSICAL DIMENSIONS

| MODEL | OPTICAL SOUND | MAG SOUND | FRONT COVER SPK | LAMP TYPE        | HI-LO LAMP SWITCH | FUNCTION CONTROL       | AMP POWER | WEIGHT LBS | WEIGHT KG | SIZE/INCHES       | SIZE/MM         |
|-------|---------------|-----------|-----------------|------------------|-------------------|------------------------|-----------|------------|-----------|-------------------|-----------------|
| ENT 0 | •             |           |                 | ELC/EJL 250W/24V | •                 | Electronic push button | 25W       | 31.5       | 14.3      | 14.4 x 11.8 x 8.1 | 365 x 300 x 206 |
| ENT 1 | •             |           | •               | "                | •                 | "                      | "         | 33.5       | 15.2      | 14.4 x 11.8 x 9.3 | 365 x 300 x 235 |
| ENT 2 | •             | •         | •               | "                | •                 | "                      | "         | "          | "         | "                 | "               |
| ENT 3 | •             | •         | •               | "                | •                 | "                      | "         | "          | "         | "                 | "               |
| SNT 0 | •             |           |                 | "                | •                 | ROTARY SWITCH          | 25W       | 30.4       | 13.8      | 14.4 x 11.8 x 8.1 | 365 x 300 x 206 |
| SNT 1 | •             |           | •               | "                | •                 | "                      | "         | 32.4       | 14.7      | 14.4 x 11.8 x 9.3 | 365 x 300 x 235 |
| SNT 2 | •             | •         | •               | "                | •                 | "                      | "         | "          | "         | "                 | "               |

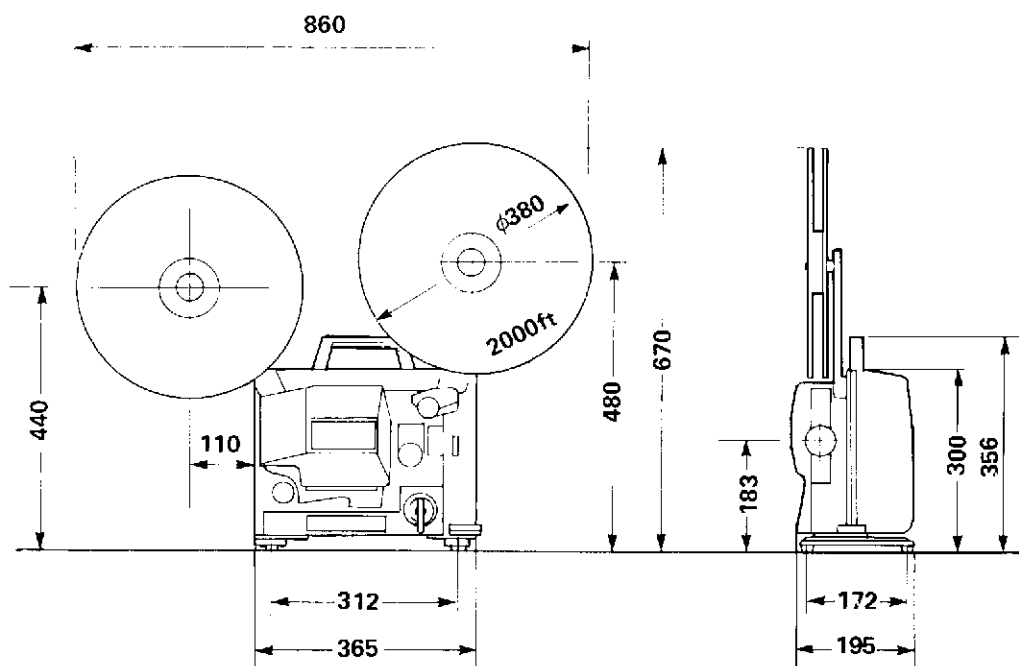

## 1-2 : SPECIFICATIONS

|  |   |
|--|---|
| <b>Power Requirement:</b>                  | Models available from 100 to 240VAC 50 or 60Hz  |
| <b>Power Consumption:</b>                  | 430 to 470 watts  |
| <b>Lamp:</b>                               | ELC, 250 watt 24 volt lamps   |
| <b>Hi-Low Lamp Switch:</b>                 | All models  |
| <b>Exciter Lamp:</b>                       | 4 volt 0.75 amp type BRK  |
| <b>Lens:</b>                               | 50mm (2") F, 1.2 6 element 160 lines center resolution standard   |
| <b>Film Speed:</b>                         | 24 frames/second standard sound speed   |
| <b>Shutter:</b>                            | 2 or 3 blade optional   |
| <b>Reel Capacity:</b>                      | 2000' (600m)  |
| <b>Controls:</b>                           | Rotary switch models SNT-, electronic touch control model ENT-  |
| <b>Still Picture:</b>                      | All models  |
| <b>Amplifier:</b>                          | All solid state   |
| <b>Power Output:</b>                       | 25 watts RMS, 8 ohm load  |
| <b>Tone Controls:</b>                      | Bass and Treble   |
| <b>Frequency Response:</b>                 | 50 – 7000Hz   |
| <b>Aux Line Out:</b>                       | 600 ohm un-balance  |
| <b>Microphone Input:</b>                   | Low impedance, un-balanced  |
| <b>Speakers:</b>                           | 10 x 15cm (4 x 6") built in rear cover speaker.<br>2 x 12.5cm (5") speakers in front cover on optional models |
| <b>Wow &amp; Flutter:</b>                  | Better than 0.2% weighted   |
| <b>Elevation:</b>                          | 13° maximum   |
| <b>Operating Temperature and Humidity:</b> | +5°C to +40°C<br>20% to 90%   |
| <b>Weight:</b>                             | (30.4 to 32.4 lbs)<br>13.8 to 14.7 kgs  |

# 315-2: PRINCIPLES OF OPERATIONS

## 2-1 : MECHANICAL SYSTEM

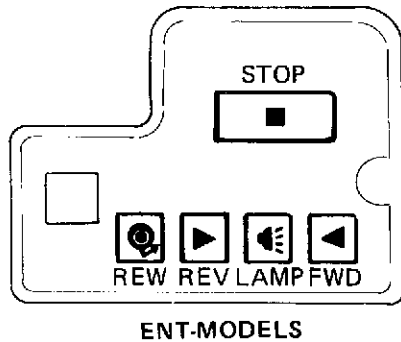

ENT-MODELS

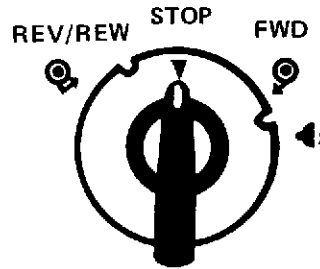

SNT-MODELS

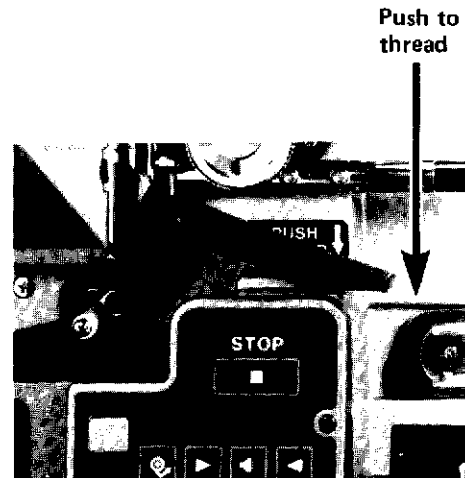

The SNT series projector is controlled by a rotary function switch and a push to thread lever. The function at each step on the control switch are as follows:

“STOP” All functions are off, except the pilot lamp illuminating the switch, and the amplifier may be operated as a P.A. when the volume control switch is on.

☉ “FORWARD” The motor runs, and the take-up reel turns.

“PUSH TO THREAD LEVER” When depressed, the film path is set to guide the film when inserted into the #1 sprocket and upper guide roller, to form the upper loop, open the film shoe and the inner guide rail allowing the film to seat in the gate. The “PUSH TO THREAD” lever forms the lower loop and the film is guided over the sound drum. When the film is seated on the #2 sprocket it exits under the tension roller. A short tug on the film will release the threading mechanism. ENT models shut “OFF” automatically when approximately 70cm (30”) of film has passed the #2 sprocket.

🔊 “LAMP” Projection lamp is switched on.

☉ “REVERSE/REWIND” With film threaded in the projector as detected by the input sensing roller this switch position becomes reverse. The 🔊 lamp may also be “ON” for reverse projection. When the film is out of the threading path as detected by the input roller the “REVERSE/REWIND” position becomes high speed reel to reel rewind.



## 2-2 : ELECTRICAL SYSTEMS

The Slim Line series projectors are available for voltage from 100V, 110V, 120V, 220V and 240V. 110/220V and 120/240V dual voltage models are also available.

According to the electrical safety regulations of various countries, UL (USA), CSA (Canada), VDE (Germany), SEV (Switzerland), SAA (Australia), SEMKO (Sweden), NEMKO (Norway), FEMKO (Finland), DEMKO (Denmark), specific models are manufactured to meet such regulations, including the option of 50/60Hz sound only, 50Hz sound & silent, 60Hz sound & silent operation.

Power Transformers vary according to the voltage range and also to the electrical safety requirements of each country. The secondary windings of all transformers provide 8V AC to the pilot lamp and exciter lamp circuits, 46V AC to the amplifier, 24V AC (high) and 22V AC (low) to the halogen projection lamp.

Motor ON/OFF, Lamp ON/OFF and Rewinding can be controlled by the function switch which consists of a cam bracket and 4 micro switches.

The projection lamp is a HALOGEN ELC type 24V 250W. Inside of the lamp house is a "high-low" switch to help extend the lamp life. In the "high" position average lamp life is approximately 50 hours and at the "low" position about 150 hours.

Note : The HALOGEN LAMP EJL type 24V 200W may also be used with some reduction in light output.

The motor is an induction type with capacitor. Motors are available for all the voltage ranges. Transformers and motors are simple and easy-to-replace modules.

AC power cords, line terminals, and all other electrical parts are designed to meet the safety requirements of the individual countries listed.

## 2-3 : SOUND SYSTEM

EIKI SNT/ENT series models are designated according to the sound playback capabilities and front cover extension speakers.

Optical Playback only: Model SNT-0, -1, ENT-0, -1

Optical & Magnetic playback: Model SNT-2, ENT-2

Optical & magnetic playback and Record: Model SNT-3 and ENT-3

Model SNT-1, -2 and ENT-1, -2 are standard with two (16 ohm, 12.5cm) speakers built in the front cover, also with one (8 ohm, 10 x 15cm) speaker built in the rear cover.

Model SNT-0 and ENT-0 are standard with one (8 ohm, 10 x 15cm) speaker only built in the rear cover.

Model SNT-3 and ENT-3 are standard with two (16 ohm, 12.5cm) speakers built in the front cover. There is no speaker in the rear cover.

The standard amplifier modules for the SNT-0, -1 and ENT-0, -1 are optical sound reproduction only.

Standard amplifier modules for the SNT-2 and ENT-2 are capable of both optical and magnetic sound reproduction.

Amplifier modules for the SNT-3 and ENT-3 are capable of both optical and magnetic sound reproduction with the additional feature of magnetic record capability.

# 315-3: SERVICE PROCEDURES

## 3-1 : PRECAUTIONS

1. EIKI SNT/ENT-series projectors have been designed for the ultimate in simplicity, and ease of service and repair. Each screw is very important, and when servicing or reassembling the projector, screws should not be omitted or carelessly lost. All screws should be firmly tightened to assure reliable projector operation after disassembly.
2. When lubricating the projector's plastic parts, silicone oil or grease should be used. Other types of lubricants may harm plastic parts.
3. EIKI projectors require a minimum of special tools. The most important is an ordinary ISO Phillips screw driver set.
4. To avoid damage to screw heads it is important to remember the adage "70% push, 30% turn." It is also important to select the right size screw driver blade. A rule of thumb is to use the largest blade possible.
5. To avoid possible electrical shock, always disconnect the projector from the power source when servicing.

## 3-2 : TOOLS AND TEST EQUIPMENT

### A. Tools:

When servicing EIKI SNT/ENT-series, ordinary ISO (Phillips type) screw drivers and single-bladed screw drivers should be enough. (EIKI Screw Driver Kit, P/N 5615 are available.)

A Molex extractor tool is most useful when replacing the pins of nylon connectors to transformer or motor.

### B. Special Tools:

EIKI Projectors have been designed so that no special tools should be required to service the projector. However, several special tools are available to speed up adjustments and maintain a closer consistency between the projectors.

Tool No. 320-01T

Cam Claw Protrusion Tool (see sec. 4-1-D)

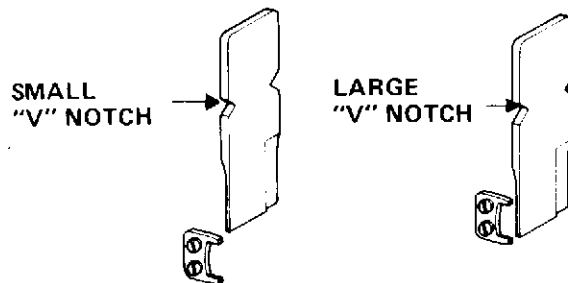

Tool No. 320-02T

Sound Lens Adjustment Tool (see sec. 7-1-B)

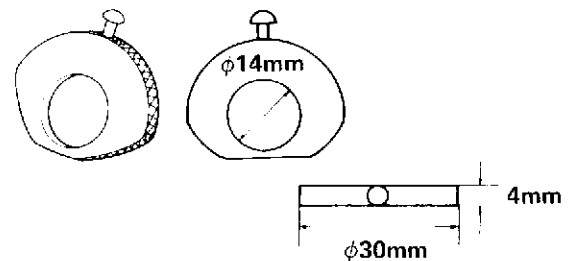

### C. Test Equipment:

A limited amount of test equipment is required for routine maintenance and modular replacement. However, when servicing the individual modules such as the amplifier, the following equipment and test films would be essential:

- a. Vom (Voltage/Ohm meter)
- b. Oscilloscope
- c. Audio AC VTVM
- d. Wow & Flutter Metter
- e. 400Hz SMPTE Test Film
- f. 3150Hz Wow & Flutter SMPTE Test Film
- g. Multi frequency SMPTE Test Film
- h. 7000Hz Sound Focus SMPTE Test Film
- i. 7000Hz Mag. Azimuth SMPTE Test Film
- j. Buzz Track SMPTE Test Film
- k. Audio Oscillator

### 3-3 : LUBRICANTS & LUBRICATION CHARTS

- Apply a few drops after every 500 operating hours.

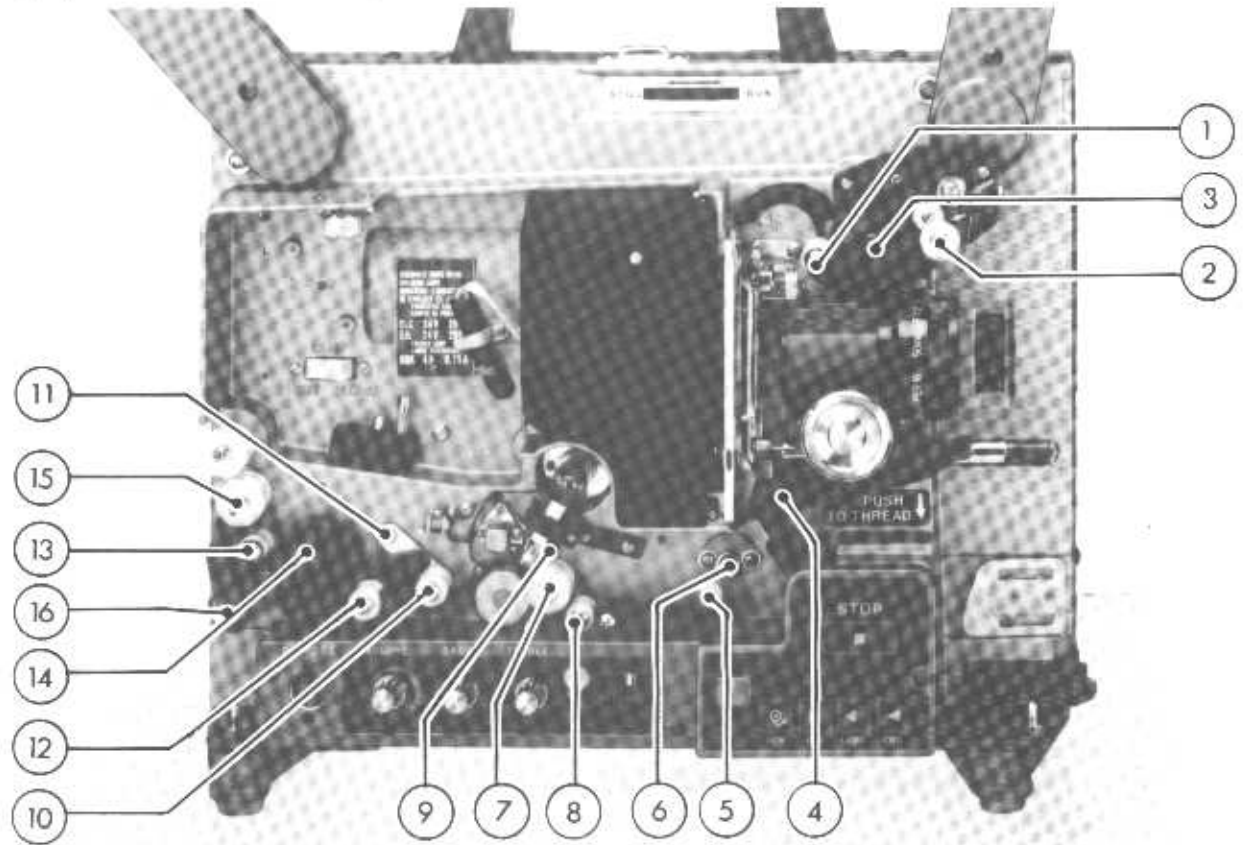

Fig. #1

| ITEM # | DESCRIPTION                   | SUGGESTED EIKI LUBRICANT PART #  | ITEM # | DESCRIPTION                          | SUGGESTED EIKI LUBRICANT PART #  |
|--------|-------------------------------|----------------------------------|--------|--------------------------------------|----------------------------------|
| 1      | #1 Sprocket Shoe Guide Roller | Silicone Oil #10 5632            | 8      | Buzz Roller Arm Fulcrum              | Molybdenum Disulfide Grease 5628 |
| 2      | #1 Guide Roller               | Molybdenum Disulfide Grease 5628 | 9      | Mag. Head Arm Fulcrum                | Petroleum Oil 5631               |
| 3      | #1 Sprocket Drum Shaft        | Petroleum Oil 5631               | 10     | Tension Guide Roller                 | Silicone Oil #10 5632            |
| 4      | Self-thread Lever Shaft       | Silicone Oil #100 5629           | 11     | Tension Guide Roller Arm Fulcrum Pin | Silicone Oil #100 5629           |
| 5      | Lower Loop Setter Roller      | Silicone Oil #100 5629           | 12     | #2 Sprocket Shoe Guide Roller        | Silicone Oil #10 5632            |
| 6      | Lower Loop Setter Arm Fulcrum | Silicone Oil #100 5629           | 13     | #2 Sprocket Shoe Large Roller        | Silicone Oil #10 5632            |
| 7      | Buzz Roller                   | Molybdenum Disulfide Grease 5628 |        |                                      |                                  |

3-3 : LUBRICANTS & LUBRICATION CHARTS

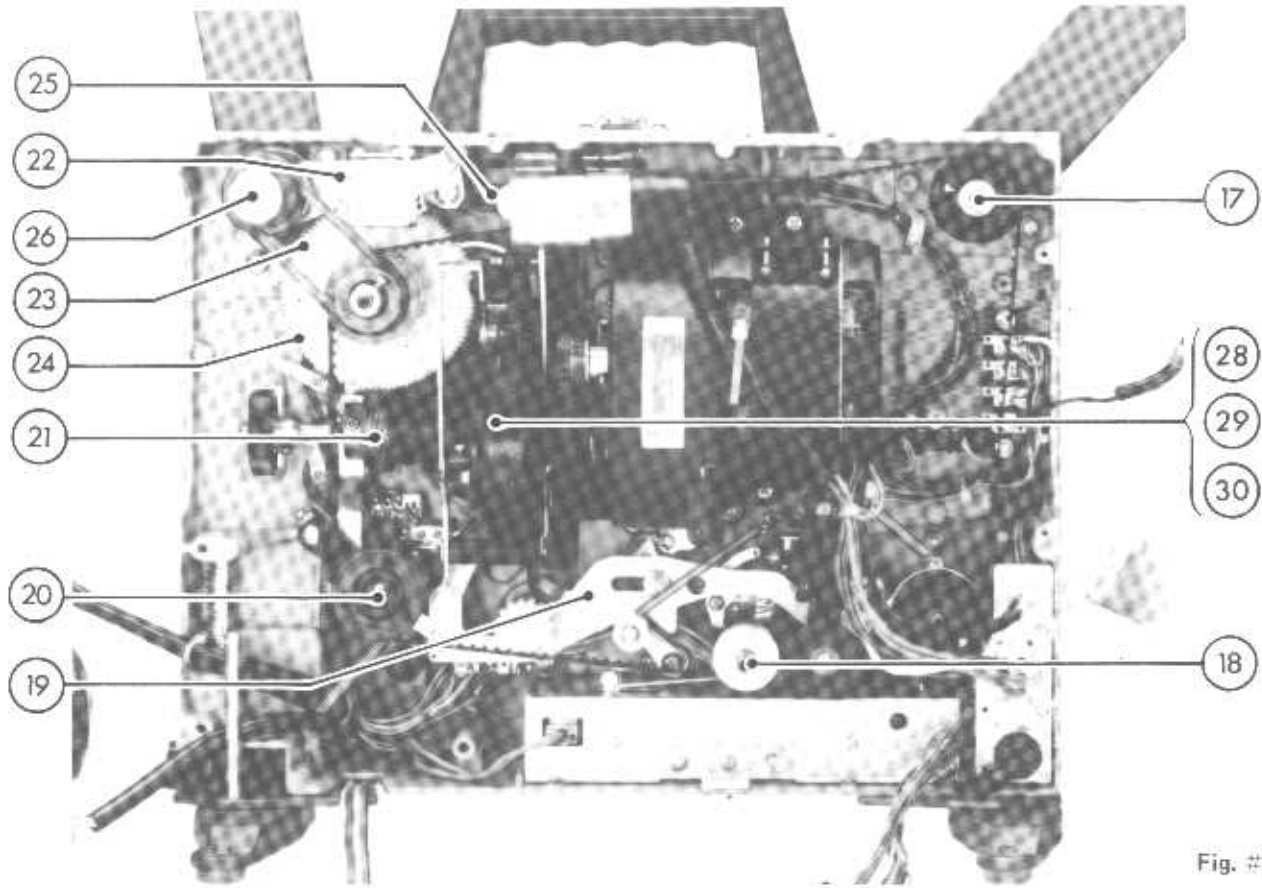

Fig. #2

| ITEM # | DESCRIPTION   | SUGGESTED EIKI LUBRICANT PART #  | ITEM # | DESCRIPTION               | SUGGESTED EIKI LUBRICANT PART #  |
|--------|---|----------------------------------|--------|---------------------------|----------------------------------|
| 14     | #2 Sprocket Drum Shaft                              | Petroleum Oil 5631               | 23     | Rewind Drive Gear         | Silicone Oil #1000 5630          |
| 15     | Rear Dampening Tension Roller                       | Silicone Oil #10 5632            | 24     | No. 1 Sprocket Drive Gear | Molybdenum Disulfide Grease 5628 |
| 16     | Rear Dampening Tension Roller Arm Fulcrum           | Molybdenum Disulfide Grease 5628 | 25     | Wire Guide                | Molybdenum Disulfide Grease 5628 |
| 17     | Take-Up Arm Drive Gear                              | Silicone Oil #100 5629           | 26     | Supply Arm Spindle Shaft  | Petroleum Oil 5631               |
| 18     | Flywheel Bearings                                   | Silicone Grease 5625             | 27     | Take-Up Arm Spindle Shaft | Petroleum Oil 5631               |
| 19     | Function Main Interlocking Bracket, at each contact | Silicone Grease 5625             | 28     | Cam Tank Module           | Molybdenum Disulfide Grease 5628 |
| 20     | Tension Gear  | Silicone Oil #100 5629           | 29     | Cam Tank Felt             | Molybdenum Disulfide Oil 5632    |
| 21     | Worm Gear assy.                                     | Silicone Grease 5625             | 30     | Cam Tank Fulcrum Pin      | Petroleum Oil 5631               |
| 22     | Rewind Control Arm                                  | Silicone Grease 5625             |        |                           |                                  |

### 3-4 : TROUBLE SHOOTING HINTS

A. There are four basic steps to trouble shooting this projector:

- a. Analyze the symptom
- b. Localize the trouble to a functional system or module
- c. Replace or repair that system or module
  - a. Isolate the trouble within the module
  - b. Locate and repair the specific trouble

B. Checking Semiconductors With A VOM:

- a. Set the ohms scale to R x 10
  - b. The forward resistance should be low
  - c. The reverse resistance should be high
- (See NOTE after Sec. D)

TRANSISTOR NPN TYPE (2SC, 2SD)

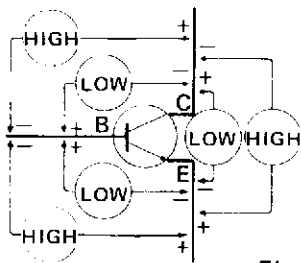

Fig. #3

TRANSISTOR PNP TYPE (2SA, 2SB)

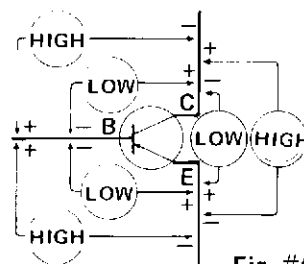

Fig. #4

Typical Amplifier Test Set-Up

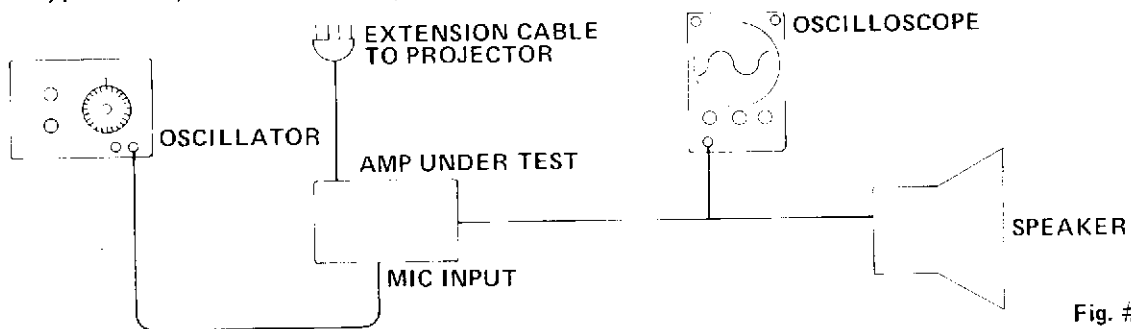

Fig. #5

DIODES

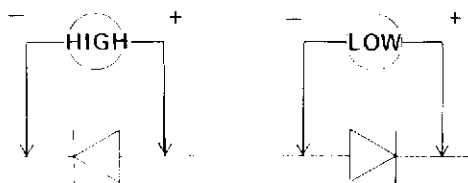



Fig. #6

- C. IC's are best checked by checking the signal input and output condition. This can be done by inserting a low level audio tone into the MIC jack and the signal path from the input of IC-1 and to the output of IC-2.
- D. Amplifier test cables can be easily made from locally available parts. A nine pin miniature tube socket and male plug can be wired as an extension power cable, allowing the amplifier to be operated away from the projector. The solar cell and exciter lamp connection can also be extended if so desired. (Fig. #5)

Note : Forward and reverse resistance LOW & HIGH is a suggested quick and easy check of out of circuit components for shorted and open junction test. A VOM will not test the quality of a semiconductor accurately.

### 3-5: SNT/ENT-Series TROUBLE SHOOTING CHART

#### I: ELECTRICAL SYSTEM

| SYMPTOM   | PROBABLE CAUSE  | REMEDY (See Table of Contents)  |
|---|---|---|
| 1. Pilot lamp not on  | <ol style="list-style-type: none"> <li>1. Not plugged in</li> <li>2. No power to the AC wall outlet</li> <li>3. Defective power cord</li> <li>4. Faulty transformer connector or defective transformer module</li> <li>5. Defective pilot lamp</li> </ol>   | <ol style="list-style-type: none"> <li>1. Check</li> <li>2. Check outlet</li> <li>3. Check and repair</li> <li>4. Repair or replace (See Sec 5-4)</li> <li>5. Replace</li> </ol>  |
| 2. Pilot lamp on, motor does not rotate at function switch position          | <ol style="list-style-type: none"> <li>1. Motor thermal switch has opened (UL type only)</li> <li>2. Defective micro switch #1, #3, #4</li> <li>3. Defective motor connectors, or not plugged in</li> <li>4. Faulty motor capacitor</li> <li>5. Defective motor module</li> </ol>                                   | <ol style="list-style-type: none"> <li>1. Allow motor to cool, check again (See Sec 5-3)</li> <li>2. Check or replace (See Sec 9-1)</li> <li>3. Check and repair (See Sec 5-3)</li> <li>4. Check or replace (See Sec 5-3)</li> <li>5. Replace (See Sec 5-3)</li> </ol>            |
| 3. Pilot lamp on, motor runs but lamp does not come on in switch position  | <ol style="list-style-type: none"> <li>1. Defective lamp</li> <li>2. Lamp is not seated in the socket properly</li> <li>3. Defective lamp socket</li> <li>4. Faulty micro switch #2</li> <li>5. Open Hi-low switch</li> <li>6. Open transformer/lamp connection</li> <li>7. Defective transformer module</li> </ol> | <ol style="list-style-type: none"> <li>1. Replace lamp</li> <li>2. Check and reseal</li> <li>3. Repair or replace</li> <li>4. Check or replace (See Sec 9-1)</li> <li>5. Check or replace</li> <li>6. Check and repair (See Sec 5-4)</li> <li>7. Replace (See Sec 5-4)</li> </ol> |
| 4. Motor does not operate in the rewind position (operates in forward)  | <ol style="list-style-type: none"> <li>1. Faulty micro switch #3, #4</li> <li>2. Defective motor connector wiring</li> <li>3. Mechanical linkage loose or out of adjustment</li> </ol>  | <ol style="list-style-type: none"> <li>1. Replace (See Sec 9-1)</li> <li>2. Check and repair (See Sec 5-3)</li> <li>3. Check and repair (See Sec 6-5-B3)</li> </ol>   |
| 5. Function switch does not follow the indicated sequence   | <ol style="list-style-type: none"> <li>1. Loose function switch knob</li> <li>2. Loose micro switch cam</li> </ol>  | <ol style="list-style-type: none"> <li>1. Reposition and tighten</li> <li>2. Reposition and tighten</li> </ol>  |

## II: SELF-THREADING SYSTEM

| SYMPTOM  | PROBABLE CAUSE   | REMEDY   |
|--|--|--|
| 6. #2 film guide (or self-thread lever) does not set the mechanism to thread | <ol style="list-style-type: none"> <li>1. Cam bracket is loose on the #2 film guide shaft</li> <li>2. Main interlocking bracket is binding or not latching with the release bracket hook</li> </ol>  | <ol style="list-style-type: none"> <li>1. Re-position and tighten (See Sec 6-4-B4)</li> <li>2. Check &amp; adjust (See Sec 6-4-B8)</li> </ol>  |
| 7. Leader or film is dimpled in the first few inches by the sprocket teeth   | <ol style="list-style-type: none"> <li>1. Film is inserted with the sprocket holes opposite the sprocket teeth</li> <li>2. Not enough clearance between the sprocket plate and the film shoe</li> <li>3. Film leader too soft</li> </ol>                               | <ol style="list-style-type: none"> <li>1. Re-insert the film correctly</li> <li>2. Check &amp; adjust (See Sec 6-4-B9)</li> <li>3. Check with another film leader</li> </ol>   |
| 8. Film does not engage at the #1 sprocket                                   | <ol style="list-style-type: none"> <li>1. Sprocket shoe roller tension spring broken or off</li> </ol>   | <ol style="list-style-type: none"> <li>1. Replace (See Sec 6-4-B1)</li> </ol>  |
| 9. Leader jams in the #1 film guide  | <ol style="list-style-type: none"> <li>1. Film leader not trimmed properly</li> <li>2. End of film is severely curled, or twisted</li> <li>3. Very soft leader</li> <li>4. #1 film guide shaft loose or bent</li> <li>5. Aperture plate assembly misaligned</li> </ol> | <ol style="list-style-type: none"> <li>1. Trim and repeat threading</li> <li>2. Straighten and re-thread</li> <li>3. Replace leader</li> <li>4. Re-align and check (See Sec 6-4)</li> <li>5. Re-align and check (See Sec 5-6-B)</li> </ol> |
| 10. Tip of the leader enters underneath the inner guide rail                 | <ol style="list-style-type: none"> <li>1. Inner guide rail bent or not aligned correctly</li> <li>2. Loose guide rail screws</li> <li>3. Film leader end severely curled or twisted</li> </ol>   | <ol style="list-style-type: none"> <li>1. Align or replace (See Sec 5-6-B)</li> <li>2. Tighten (See Sec 5-6-B)</li> <li>3. Trim and re-thread</li> </ol>   |
| 11. Film does not thread through the gate, and jams                          | <ol style="list-style-type: none"> <li>1. Film leader not trimmed properly</li> <li>2. Leader is severely curled or twisted, or too soft</li> <li>3. Too much #1 film shoe clearance</li> <li>4. Insufficient side travel of the inner guide rail</li> </ol>           | <ol style="list-style-type: none"> <li>1. Trim</li> <li>2. Trim, straighten or replace</li> <li>3. Check &amp; adjust (See Sec 6-4-B1)</li> <li>4. Check &amp; adjust (See Sec 5-6-B)</li> </ol>   |



### III: MECHANICAL SYSTEM

| SYMPTOM  | PROBABLE CAUSE  | REMEDY  |
|--|---|---|
| 12. Chattering noise during threading  | 1. Claw is not completely retracted   | 1. Check & adjust (See Sec 5-1-D)   |
| 13. Clicking noise during threading  | 1. Claw is hitting the shutter blade  | 1. Check & adjust (See Sec 5-1-D)   |
| 14. Curled film goes over the loop setter roller                                 | 1. Severely curled film   | 1. Straighten the lead end  |
| 15. Film goes under the #3 film guide or comes out                               | 1. #2 Film guide defective<br>2. #3 Film guide defective<br>3. #2 and #3 film guides are not aligned<br>4. Curled film  | 1. Replace<br>2. Replace<br>3. Check & adjust (See Sec 6-4-B4)<br>4. Straighten the lead end  |
| 16. Film will not thread over the sound drum                                     | 1. Rough surface on the film guide restricting the film travel<br>2. Pinch roller not completely released from the sound drum<br>3. Pinch roller bound up or out of alignment                 | 1. Remove & inspect the film guide<br>2. Check & adjust (See Sec 6-4-B5)<br>3. Check, adjust and lubricate (See Sec 6-4-B5)                                 |
| 17. Film stops at the #2 sprocket  | 1. Rough surface or restriction to the film path on the film guide<br>2. #2 sprocket teeth or cover plate loose<br>3. Tension roller is too low<br>4. #2 sprocket shoe clearance is too tight | 1. Remove the film guide and inspect<br>2. Tighten and re-time (See Sec 6-4-B9)<br>3. Check & adjust (See Sec 6-4-B6)<br>4. Check & adjust (See Sec 6-4-B9) |
| 18. Film comes out of the #2 sprocket shoe                                       | 1. #2 sprocket plate is loose<br>2. #2 sprocket shoe spring weak or missing   | 1. Tighten and check timing (See Sec 6-4-B9)<br>2. Check & replace (See Sec 6-4-B9)   |
| 19. Self-threading mechanism not released with a tug on the film                 | 1. Release bracket spring is too weak or broken   | 1. Check & adjust (See Sec 6-4-B8)  |
| 20. FILM GUARD does not shut off power when upper loop is lost (ENT Models only) | 1. Film guard arm is in wrong position<br>2. Defective micro switch   | 1. Check & adjust (See Sec 5-8-B)<br>2. Check & replace (See Sec 5-8-B)   |
| 21. Pilot lamp on, motor runs but film does not advance                          | 1. Broken or defective motor belt<br>2. Motor pulley loose<br>3. Main drive belt off or broken<br>4. Still picture lever engaged<br>5. Defective still clutch                                 | 1. Replace<br>2. Check & tighten<br>3. Check & replace<br>4. Release to normal run position<br>5. Check & repair  |

**(MECHANICAL SYSTEM)**

| SYMPTOM  | PROBABLE CAUSE   | REMEDY   |
|--|--|--|
| 22. Film speed is too slow or too fast                           | <ol style="list-style-type: none"> <li>1. Belt installed incorrectly</li> <li>2. Incorrect motor pulley</li> <li>3. Incorrect line voltage</li> </ol>  | <ol style="list-style-type: none"> <li>1. Re-locate belt position</li> <li>2. Replace</li> <li>3. Check</li> </ol>   |
| 23. Film comes out of the path, or lifts off near the sound drum | <ol style="list-style-type: none"> <li>1. #2 sprocket shoe rollers not seating properly</li> <li>2. Buzz pinch roller's tension spring is off, or defective</li> </ol>   | <ol style="list-style-type: none"> <li>1. Check &amp; adjust<br/>(See Sec 6-4-B9)</li> <li>2. Hook spring, or replace<br/>(See Sec 6-4-B5)</li> </ol>  |
| 24. Excessive take-up torque in "forward"                        | <ol style="list-style-type: none"> <li>1. Adjusted too tight</li> <li>2. Dirty or sticky take-up arm belt or spindle</li> <li>3. Take-up arm belt installed incorrectly</li> </ol>   | <ol style="list-style-type: none"> <li>1. Loosen tension adjustment screw (See Sec 6-1)</li> <li>2. Clean or replace (See Sec 6-1)</li> <li>3. Check &amp; re-install (See Sec 6-1)</li> </ol>   |
| 25. Insufficient take-up tension or no take-up                   | <ol style="list-style-type: none"> <li>1. Take-up tension adjusted too loose</li> <li>2. Worn or oily belt</li> <li>3. Binding spindle shaft</li> <li>4. Defective take-up drive clutch &amp; cam</li> <li>5. Broken take-up belt</li> </ol>   | <ol style="list-style-type: none"> <li>1. Re-adjust (See Sec 6-1)</li> <li>2. Clean or replace</li> <li>3. Clean &amp; lubricate</li> <li>4. Check &amp; repair</li> <li>5. Replace</li> </ol>   |
| 26. Weak back tension of the supply reel in "forward"            | <ol style="list-style-type: none"> <li>1. Reverse clutch cover pulley binding and clutch cam is not releasing, or clutch cover pulley defective</li> <li>2. Clutch cover pulley has no end play on the #1 sprocket drum shaft</li> <li>3. Clutch cam seated incorrect, or defective</li> <li>4. Clutch cam binding between clutch cover pulley and spacer</li> <li>5. Missing or weak back tension spring</li> </ol> | <ol style="list-style-type: none"> <li>1. Check &amp; adjust, or replace<br/>(See Sec 6-2, 6-5-B3)</li> <li>2. Check &amp; adjust</li> <li>3. Check &amp; reposition, or replace</li> <li>4. Check &amp; adjust</li> <li>5. Replace (See Sec 6-2)</li> </ol> |
| 27. Weak back tension of the take-up reel in "reverse"           | <ol style="list-style-type: none"> <li>1. Drive gear is binding, or has no end play on the drive pulley shaft</li> <li>2. Clutch cam seated incorrect, or binding between drive gear and clutch cover assy., defective clutch cam</li> <li>3. Drive gear, or clutch cover defective</li> </ol>   | <ol style="list-style-type: none"> <li>1. Check &amp; clean, or adjust<br/>(See Sec 6-7-B)</li> <li>2. Check &amp; reposition<br/>(See Sec 6-7-B)</li> <li>3. Check &amp; replace</li> </ol>   |

**(MECHANICAL SYSTEM)**

| SYMPTOM   | PROBABLE CAUSE  | REMEDY   |
|---|---|--|
| 28. Take-up poor or not at all in "reverse"   | <ol style="list-style-type: none"> <li>1. Supply arm belt broken</li> <li>2. Reverse belt broken or oily</li> <li>3. Clutch cam not engaging</li> </ol>   | <ol style="list-style-type: none"> <li>1. Replace</li> <li>2. Clean or replace</li> <li>3. Check &amp; repair (See Sec 6-7-B)</li> </ol>   |
| 29. Loop setter roller continues to activate, or activates erratically in "forward" | <ol style="list-style-type: none"> <li>1. Damaged or poor film</li> <li>2. Insufficient gear spring tension</li> <li>3. Loop setter roller in the wrong position</li> <li>4. #2 sprocket plate loose</li> <li>5. Lower loop is too small</li> <li>6. Insufficient claw protrusion</li> <li>7. Broken claw</li> <li>8. Too much take-up tension</li> <li>9. Incorrect clearance between the loop setter gear and main drive belt</li> <li>10. Loop setter gear, or main drive belt defective, or broken</li> <li>11. Insufficient tension of the film shoe springs</li> <li>12. Loop setter timing is incorrect</li> </ol> | <ol style="list-style-type: none"> <li>1. Repair or replace</li> <li>2. Stretch or replace (See Sec 6-3-B)</li> <li>3. Relocate &amp; check (See Sec 6-3-B)</li> <li>4. Check &amp; tighten</li> <li>5. Check #2 sprocket timing (See Sec 6-3-B)</li> <li>6. Check (See Sec 5-1-D1)</li> <li>7. Check &amp; replace</li> <li>8. Check &amp; lubricate take-up spindle cork (See Sec 6-1-B1)</li> <li>9. Adjust clearance (See Sec 6-3-C)</li> <li>10. Replace</li> <li>11. Stretch or replace</li> <li>12. Check &amp; adjust (See Sec 6-3-C)</li> </ol> |
| 30. Film continues to flap on loop setter roller in "forward"                       | <ol style="list-style-type: none"> <li>1. Loop setter gear shaft is binding, or tight in hub</li> <li>2. Loop setter gear spring tension too strong</li> </ol>  | <ol style="list-style-type: none"> <li>1. Check &amp; lubricate</li> <li>2. Adjust spring tension, or replace</li> </ol>   |
| 31. Lower loop is lost in "reverse"   | <ol style="list-style-type: none"> <li>1. Reverse rubber roller is not driving the flywheel set collar</li> <li>2. Reverse rubber roller binding</li> <li>3. #2 sprocket not transporting film</li> </ol>   | <ol style="list-style-type: none"> <li>1. Check reverse rubber roller's function (See Sec 6-7-B)</li> <li>2. Clean &amp; remove the cause of binding</li> <li>3. Check &amp; adjust (See Sec 6-4-B9)</li> </ol>  |
| 32. Upper loop is lost in "forward"   | <ol style="list-style-type: none"> <li>1. Damaged, or poor film</li> <li>2. #1 sprocket teeth plate loose</li> <li>3. #1 sprocket shoe not seating properly</li> <li>4. Loop setter roller continues to activate or activates erratically</li> </ol>  | <ol style="list-style-type: none"> <li>1. Repair or replace</li> <li>2. Check &amp; tighten</li> <li>3. Check &amp; adjust (See Sec 6-4-B1)</li> <li>4. See Symptom No. 29</li> </ol>  |

**(MECHANICAL SYSTEM)**

| SYMPTOM  | PROBABLE CAUSE   | REMEDY   |
|--|--|--|
| 33. Upper loop is lost in "reverse"  | <ol style="list-style-type: none"> <li>1. Damaged, or poor film</li> <li>2. #1 sprocket shoe clearance is too great</li> <li>3. Claw protrusion incorrect</li> </ol>   | <ol style="list-style-type: none"> <li>1. Repair, or replace</li> <li>2. Check &amp; adjust (See Sec 6-4-B1)</li> <li>3. Check &amp; adjust (See Sec 5-1-D1)</li> </ol>  |
| 34. Excessive noise in the film gate in "forward" with a good undamaged film | <ol style="list-style-type: none"> <li>1. Upper loop too small</li> <li>2. Film contacting the loop setter roller</li> <li>3. Dirty film gate</li> <li>4. Loose claw</li> <li>5. Incorrect claw protrusion</li> <li>6. Inner guide rail binding</li> <li>7. Film shoe bend, worn or binding</li> <li>8. Claw position incorrect</li> <li>9. Weak or broken cam follower spring</li> </ol>  | <ol style="list-style-type: none"> <li>1. Check #1 sprocket timing</li> <li>2. Check #2 sprocket and loop setter timing (See Sec 6-3-B)</li> <li>3. Clean</li> <li>4. Tighten</li> <li>5. Check</li> <li>6. Check &amp; adjust</li> <li>7. Check &amp; replace</li> <li>8. Check &amp; adjust (See Sec 5-1-D)</li> <li>9. Replace (See Sec 5-1-D)</li> </ol>   |
| 35. Excessive noise in "reverse" only  | <ol style="list-style-type: none"> <li>1. Claw position incorrect</li> <li>2. Claw angle is incorrect</li> </ol>   | <ol style="list-style-type: none"> <li>1. Check &amp; adjust (See Sec 5-1-D)</li> <li>2. Check &amp; adjust (See Sec 5-1-D)</li> </ol>   |
| 36. Excessive film gate noise  | <ol style="list-style-type: none"> <li>1. Film shoe closing mechanism does not completely close</li> <li>2. Lower loop too small</li> </ol>  | <ol style="list-style-type: none"> <li>1. See threading system (See Sec 6-4-B3, 5-7)</li> <li>2. Re-set the function switch</li> </ol>   |
| 37. Unsteady picture   | <ol style="list-style-type: none"> <li>1. Emulsion or dirt build-up on the aperture plate or film shoe</li> <li>2. Incorrect claw protrusion</li> <li>3. Film shoe not seating completely</li> <li>4. Weak film shoe springs</li> <li>5. Improper claw alignment or defective claw</li> <li>6. Claw stroke not correct</li> <li>7. Worn cam follower (cam gliding pin), or sliding pin</li> <li>8. Weak claw lever spring</li> <li>9. Inner guide rail spring missing or weak</li> <li>10. Threading mechanism does not close the gate completely</li> </ol> | <ol style="list-style-type: none"> <li>1. Clean</li> <li>2. Check &amp; adjust (See Sec 5-1-D)</li> <li>3. Check &amp; adjust (See Sec 5-7)</li> <li>4. Adjust or replace (See Sec 5-7)</li> <li>5. Check, adjust or replace (See Sec 5-1-D)</li> <li>6. Adjust (See Sec 5-1-D)</li> <li>7. Replace (See Sec 5-1-D)</li> <li>8. Replace (See Sec 5-1-D)</li> <li>9. Replace (See Sec 5-6)</li> <li>10. See threading mechanism adjustment (See Sec 6-4)</li> </ol> |
|  | — to be continued —  |  |

(MECHANICAL SYSTEM)

| SYMPTOM   | PROBABLE CAUSE  | REMEDY   |
|---|---|--|
| 37. Unsteady picture<br>— continued —                       | 11. Worn cam or cam tank<br>12. Inner guide rail worn or binding<br>13. Outer guide rail loose<br>14. Worn claw lever fulcrum bushing   | 11. Check & replace<br>(See Sec 5-1-D)<br>12. Check & replace or clean<br>(See Sec 5-6)<br>13. Check & tighten (See Sec 5-6)<br>14. Check & replace<br>(See Sec 5-1-D) |
| 38. Travel ghost  | 1. Incorrect shutter blade position   | 1. Adjust (See Sec 5-1-F)  |
| 39. Insufficient framing                                    | 1. Aperture plate does not move freely, or loose<br>2. Claw position or stroke is incorrect<br>3. Worn cam follower (cam gliding pin)   | 1. Disassemble and clean, or check & tighten (See Sec 5-6)<br>2. Adjust (See Sec 5-1-D)<br>3. Replace (See Sec 5-1-D)  |
| 40. Excessive cam tank noise                                | 1. Defective claw lever spring<br>2. Defective plate spring<br>3. Worn cam follower (cam gliding pin)<br>4. Fulcrum bushing worn<br>5. Cam shaft bearings defective or worn   | 1. Replace (See Sec 5-1)<br>2. Replace (See Sec 5-1)<br>3. Replace (See Sec 5-1)<br>4. Replace (See Sec 5-1)<br>5. Replace (See Sec 5-1)                               |
| 41. Film transport does not stop in still picture operation | 1. Shutter pulley seized<br>2. Still picture lever shoulder screws loose  | 1. Remove cam tank, clean & lubricate pulley (See Sec 4-1-G)<br>2. Tighten screws (See Sec 4-1-G)  |
| 42. Weak or slow rewind                                     | 1. Worn or slipping motor belt<br>2. Take-up arm spindle not rotating freely<br>3. Rewind solenoid not activated<br>4. Rewind clutch cork pads slipping   | 1. Check & replace<br>2. Check & adjust (See Sec 6-1)<br>3. Check & repair<br>4. Replace (See Sec 6-5-B2)  |
| 43. No rewind   | 1. Rewind function switch not activated<br>2. Defective function micro switch<br>3. Rewind solenoid not activated<br>4. Rewind clutch not engaged<br>5. Rewind lever is not activated<br>6. Motor does not reverse directions | 1. Check & adjust (See Sec 9-1)<br>2. Replace (See Sec 9-1)<br>3. Check & repair<br>4. Repair or replace<br>5. Check & adjust<br>(See Sec 6-5-B3)<br>6. Check & repair |

(MECHANICAL SYSTEM)

| SYMPTOM  | PROBABLE CAUSE   | REMEDY  |
|--|--|---|
| 44. Noisy rewind   | 1. Rewind gears not fully engaged<br>2. Worn or defective rewind gears<br>3. Dry or worn rewind cork   | 1. Adjust position of rewind gears activating lever (See Sec 6-5-B3)<br>2. Replace (See Sec 6-5-B3)<br>3. Replace   |
| 45. Uneven focus   | 1. Projector not facing screen at right angles<br>2. Film shoe not seated properly<br>3. Dirty film shoe or aperture plate<br>4. Film not seated in the gate<br>5. Inner guide rails sticking<br>6. Defective or incorrect lens<br>7. Lens holder misaligned | 1. Correct position for right angle<br>2. Check & adjust (See Sec 5-6, 5-7)<br>3. Clean<br>4. Check and rethread film<br>5. Remove and clean or replace rail spring (See Sec 5-6)<br>6. Replace<br>7. Check & adjust (See Sec 5-7-B1) |
| 46. STILL-RUN lever is activated to "STILL" but no still picture | 1. Still picture clutch mechanism is out of adjustment<br>2. Shutter is blocking aperture  | 1. Check & adjust (See Sec 5-1-G2)<br>2. Rotate shutter with inching knob   |
| 47. Film frame burns in Still                                    | 1. Heat filter is not dropping in place  | 1. Check & adjust   |
| 48. Lamp life if abnormally short                                | 1. Poor lamp socket connection<br>2. Cooling is restricted<br>3. Defective lamps, or incorrect lamp other than EIKI ELC type<br>4. Excessive or fluctuating AC line voltage  | 1. Replace lamp socket<br>2. Locate & remove<br>3. Check & replace<br>4. Check AC line voltage  |

#### IV: LAMP CIRCUIT

| SYMPTOM                       | PROBABLE CAUSE   | REMEDY  |
|-------------------------------|--|---|
| 49. Insufficient illumination | <ol style="list-style-type: none"><li data-bbox="830 511 1424 601">1. Weak lamp, or incorrect lamp other than EIKI ELC type</li><li data-bbox="830 615 1424 705">2. Hi-low switch in the low position</li><li data-bbox="830 718 1261 753">3. Slow or defective lens</li><li data-bbox="830 770 1233 804">4. Low AC line voltage</li><li data-bbox="830 822 1424 912">5. Light heat shield blocking part of the aperture</li><li data-bbox="830 926 1424 1016">6. Lamp socket &amp; bracket not aligned properly</li></ol> | <ol style="list-style-type: none"><li data-bbox="1465 511 1800 545">1. Check &amp; replace</li><li data-bbox="1465 615 1884 649">2. Switch to Hi position</li><li data-bbox="1465 718 1800 753">3. Try another lens</li><li data-bbox="1465 770 1764 804">4. Check AC line</li><li data-bbox="1465 822 1855 912">5. Re-align heat shield<br/>(See Sec 5-1-G)</li><li data-bbox="1465 926 1952 1016">6. Check &amp; correct position<br/>(See Sec 8-1)</li></ol> |

## V: SOUND SYSTEM

| SYMPTOM                                     | PROBABLE CAUSE  | REMEDY  |
|---|---|---|
| 50. No sound and the exciter lamp is not on | <ol style="list-style-type: none"> <li>1. Amplifier is not turned on</li> <li>2. 9 pin amplifier plug defective</li> <li>3. Defective exciter lamp</li> <li>4. Defective exciter lamp socket</li> <li>5. Exciter lamp fuse blown</li> <li>6. Slide switch in the mag position (Opt/Mag Models only)</li> <li>7. Defective amplifier module</li> <li>8. Defective exciter lamp power supply of the transformer module</li> </ol>   | <ol style="list-style-type: none"> <li>1. Turn on</li> <li>2. Check &amp; repair, or replace</li> <li>3. Replace</li> <li>4. Replace or repair</li> <li>5. Check &amp; replace</li> <li>6. Switch to optical</li> <li>7. Repair or replace (See Sec 4-2)</li> <li>8. Repair or replace (See Sec 4-4)</li> </ol>   |
| 51. No sound, Exciter lamp is on            | <ol style="list-style-type: none"> <li>1. Amplifier volume is too low</li> <li>2. 5 pin sound terminal plug disconnected or defective</li> <li>3. Rear cover speaker unplugged</li> <li>4. Defective speaker</li> <li>5. Defective extension speaker jack</li> <li>6. 2 amp fuse blown</li> <li>7. Defective solar cell or connections</li> <li>8. Dirt or foreign object in sound optics</li> <li>9. Defective amplifier module</li> <li>10. Defective Amp. power supply circuit of the transformer module</li> <li>11. Defective audio mute switch</li> </ol> | <ol style="list-style-type: none"> <li>1. Check &amp; adjust</li> <li>2. Check &amp; replace (See Sec 4-2)</li> <li>3. Check &amp; plug in</li> <li>4. Replace</li> <li>5. Repair or replace</li> <li>6. Replace</li> <li>7. Repair &amp; replace (See Sec 4-2)</li> <li>8. Clean</li> <li>9. Replace</li> <li>10. Check &amp; replace (See Sec 4-4 or 5-4)</li> <li>11. Check &amp; replace</li> </ol>                           |
| 52. Poor sound or low volume                | <ol style="list-style-type: none"> <li>1. Incorrect exciter lamp</li> <li>2. Defective exciter lamp</li> <li>3. Dirty exciter lamp</li> <li>4. Dirt in the sound focus lens or defective lens</li> <li>5. Sound optics incorrectly aligned</li> <li>6. Low exciter lamp voltage, or low AC supply voltage</li> <li>7. Weak or defective solar cell</li> <li>8. Defective speakers</li> <li>9. Poor film quality</li> <li>10. Defective amplifier module</li> </ol>  | <ol style="list-style-type: none"> <li>1. Check &amp; replace</li> <li>2. Replace</li> <li>3. Clean</li> <li>4. Clean or replace (See Sec 7-1)</li> <li>5. Re-align sound pick-up system (See Sec 7-1)</li> <li>6. Check &amp; repair amplifier exciter lamp supply (See Sec 5-4)<br/>Check wall outlet</li> <li>7. Replace</li> <li>8. Replace</li> <li>9. Check with another film</li> <li>10. Replace (See Sec 4-2)</li> </ol> |



(SOUND SYSTEM)

| SYMPTOM                                      | PROBABLE CAUSE   | REMEDY  |
|--|--|---|
| 53. No sound (magnetic only)                 | <ol style="list-style-type: none"><li>1. Mag/opt switch in the optical position</li><li>2. Magnetic head not in contact with the sound track</li><li>3. Defective magnetic reproduce head</li><li>4. Mag/opt switch defective</li><li>5. Defective amplifier module</li><li>6. Mag/opt switch defective, or bad connection</li><li>7. Defective speakers, or speaker connections</li></ol> | <ol style="list-style-type: none"><li>1. Check</li><li>2. Check &amp; adjust (See Sec 7-2)</li><li>3. Replace (See Sec 7-2)</li><li>4. Replace</li><li>5. Replace</li><li>6. Check &amp; replace</li><li>7. Check &amp; replace</li></ol>   |
| 54. Poor sound or low volume (magnetic only) | <ol style="list-style-type: none"><li>1. Dirty magnetic head</li><li>2. Head not making good contact with the film</li><li>3. Incorrect sound head alignment</li><li>4. Defective magnetic head</li><li>5. Defective speaker</li><li>6. Poor sound track</li><li>7. Defective amplifier module</li></ol>   | <ol style="list-style-type: none"><li>1. Clean</li><li>2. Adjust (See Sec 7-2)</li><li>3. Align (See Sec 7-2)</li><li>4. Replace</li><li>5. Replace</li><li>6. Check with another film</li><li>7. Replace or repair (See Sec 4-2)</li></ol> |
| 55. Exciter lamp fuse blows                  | <ol style="list-style-type: none"><li>1. Excessive AC line voltage</li><li>2. Incorrect fuse</li><li>3. Incorrect exciter lamp</li><li>4. Defective exciter lamp power supply</li><li>5. Defective exciter lamp</li><li>6. Defective exciter lamp socket</li></ol>   | <ol style="list-style-type: none"><li>1. Check</li><li>2. Check &amp; replace</li><li>3. Replace</li><li>4. Check &amp; repair (See Sec 5-4)</li><li>5. Replace</li><li>6. Replace</li></ol>  |
| 56. Amplifier fuse blows                     | <ol style="list-style-type: none"><li>1. Incorrect fuse</li><li>2. Improper connection to an external speaker system</li><li>3. Defective amplifier module</li></ol>   | <ol style="list-style-type: none"><li>1. Check &amp; replace</li><li>2. Check</li><li>3. Repair or replace (See Sec 4-2)</li></ol>  |
| 57. Excessive amplifier hum (optical)        | <ol style="list-style-type: none"><li>1. Defective exciter lamp supply</li><li>2. Improper connection to external speaker system</li><li>3. Defective solar cell or connections to amplifier</li><li>4. Front or rear cover speaker jacks not insulated from the chassis properly</li><li>5. Defective amplifier module</li></ol>  | <ol style="list-style-type: none"><li>1. Check voltage &amp; repair</li><li>2. Re-connect correctly</li><li>3. Check &amp; repair</li><li>4. Check &amp; repair</li><li>5. Repair or replace</li></ol>                                      |

(SOUND SYSTEM)

| SYMPTOM                                      | PROBABLE CAUSE  | REMEDY   |
|--|---|--|
| 58. Excessive Hum (magnetic)                 | 1. Motor shield not installed<br>2. Defective magnetic head<br>3. Magnetic head not in contact with the film<br>4. Poor shielding to the head or the head coil shorted to the projector's frame<br>5. Improper connection to external speaker<br>6. Poor film recording<br>7. Defective amplifier module  | 1. Check<br>2. Replace (See Sec 7-2)<br>3. Adjust<br><br>4. Repair<br><br>5. Re-connect correctly<br><br>6. Check with another film<br>7. Repair or replace  |
| 59. Excessive wow and flutter                | 1. Flywheel is not installed<br>2. Insufficient flywheel plate spring tension<br>3. Buzz roller not riding against the sound drum<br>4. Weak buzz roller tension<br>5. Tension roller spring is weak, or too strong<br>6. Uneven take-up torque<br>7. Rear dampening roller tension is weak<br>8. Defective sound drum bearings<br>9. Any film path rollers not rotating freely<br>10. Any drive gears rotating eccentrically<br>11. Uneven contact of film sound track<br>12. Film contacts the lower loop setter roller<br>13. Excessive film lubricant | 1. Check & install<br>2. Adjust by bending or replace<br><br>3. Adjust & correct<br><br>4. Adjust or replace<br>5. Adjust or replace<br><br>6. Repair & adjust<br>7. Adjust or replace spring<br><br>8. Replace<br><br>9. Check & lubricate<br><br>10. Check & adjust, lubricate<br><br>11. Check & adjust<br><br>12. See loop setter adjustment<br><br>13. Clean film and film path |
| 60. Sound not stabilized soon after starting | 1. Insufficient flywheel plate spring tension<br>2. Weak pinch roller spring  | 1. Check & adjust<br>2. Check & replace  |

# 315-4: MODULE REMOVAL AND INSTALLATION PROCEDURES

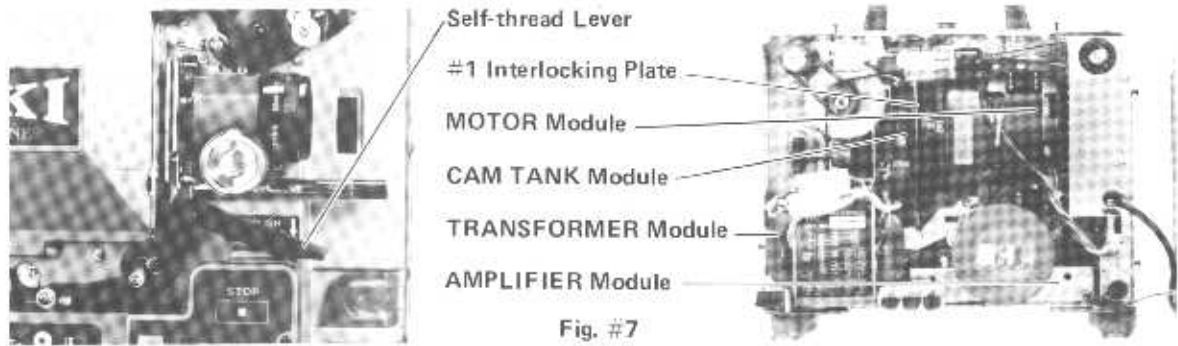

## 4-1 : CAM TANK MODULE

1. Unplug the projector and remove the rear cover. (5 screws)
2. Make sure the self-thread lever is released.
3. Remove transformer module. (4-4)
4. Remove motor belt, Main drive belt.
5. Unhook the cable from the still picture clutch by removing the small screw in the STILL-RUN control Arm.
6. Unscrew the 2 screws supporting the cam tank.
7. Remove #1 sprocket interlocking plate from #1 film guide.
8. Remove cam tank slowly and carefully. Claw should not touch the main casting or any other metal parts.
9. Re-installation can be done by reversing the above procedure. Checking the adjustment of claw and No. 2 sprocket teeth timing is necessary and critical. See section 5-1. Also check loop setter timing adjustment, See section 6-3.

CAM TANK MODULE



Fig. #8

## 4-2 : AMPLIFIER MODULE

1. Remove the three transformer mounting screws and the fuse holder.
2. Remove flywheel.
3. Unplug the rear cover speaker cord.
4. (for ENT-2, SNT-2 models only) Unscrew the shoulder screw hooking up the OPT/MAG switch lever, and remove the lever.
5. Unplug 5 pin sound terminal connector.
6. Unplug MT 9 Pin socket.
7. Amplifier is hooked by the two screws. Push in on the amplifier's chassis, allowing the edge of the chassis to release from under the two screws mounted in the bottom of the casting. Sometimes a slight pry with a flat blade screw driver may be necessary to remove a stubborn amplifier. Slide the amplifier out.

AMPLIFIER MODULE

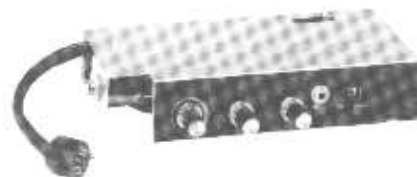
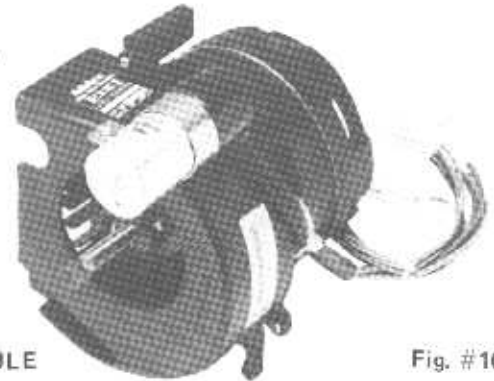

Fig. #9

#### 4-3 : MOTOR MODULE

1. Remove motor belt.
2. Disconnect motor nylon connector.
3. Unscrew 3 mounting screws.
4. Remove motor module.
5. To re-install reverse the above procedures.  
Don't forget to re-connect the nylon connector(s).



MOTOR MODULE

Fig. #10

#### 4-4 : TRANSFORMER MODULE

1. Remove the three mounting screws.
2. Unplug nylon connectors.
3. To re-install reverse the above procedures.  
(Care should be taken that the wires are routed away from any moving parts of the projector)

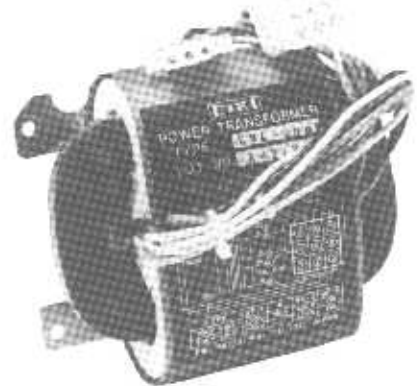

TRANSFORMER MODULE

Fig. #11

#### 4-5 : FILM SHOE AND BRACKET ASSY., LENS HOLDER ASSY., FILM GATE ASSY.

##### (A) Film Shoe and Bracket Assy.

1. Push the film shoe open until it locks in position.
2. Pull from the top of the film shoe bracket.
3. To re-insert the film shoe and bracket assy., slide the pin into the lower slot of the reception bracket and swing the film shoe and bracket assy. into the upper slot until the plate spring latches it in place.



Fig. #12

(B) Lens Holder assy.

1. Unscrew the lens lock screw.
2. Rotate the focus knob and advance the lens until rear of the lens can be removed.
3. Unscrew the Phillips mounting screws (1 on the top, using a Small Phillips driver, 2 at the bottom)
4. To re-install, reverse the procedure.
5. Care should be taken to avoid adjusting the two small slotted screws, otherwise the side to side focus will be affected.

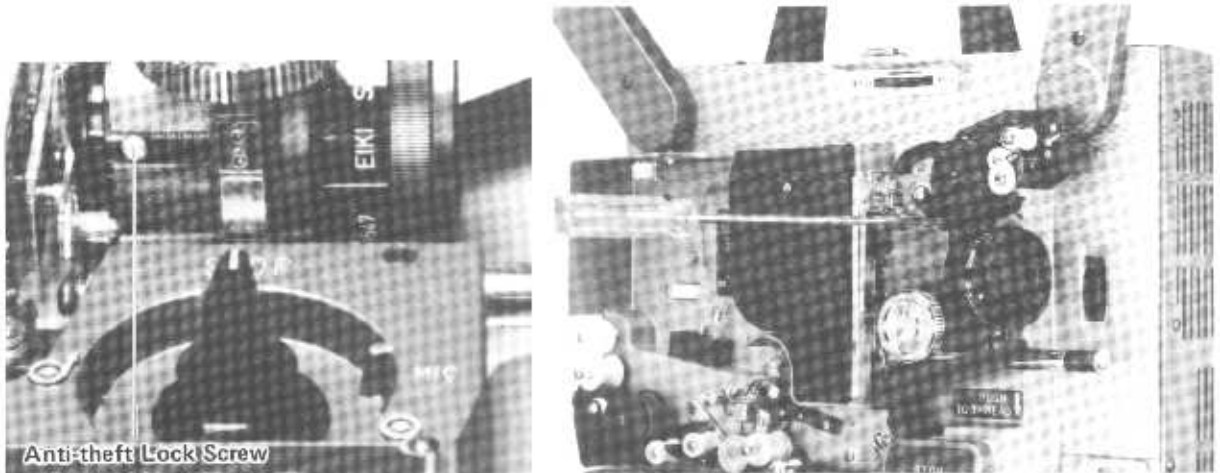

Fig. #13

Note : For USA and Canadian models, anti-theft lock screw secures the lens.

(C) Film Gate Assembly Removal

1. Release the threading mechanism.
2. Using a long screwdriver uncrew the top mounting screw. Fig #14
3. Locate the hole in the threading lever guide, Fig. #14, and insert a long screwdriver to - remove the lower mounting screw.
4. Carefully remove the aperture plate assembly. Care should be taken not to damage the claw, which may be protruding through the slot in the aperture plate.
5. To re-install, reverse the above procedures.
6. Check to be sure the inner guide rail is retracted when the self-thread liver is pushed and the film shoe seats properly when the self-thread mechanism is released.



Fig. #14

# 315-5: MODULE REPAIR AND ADJUSTMENTS

## 5-1 : CAM TANK MODULE

### A. SPECIFICATIONS

1. Revolution  
24 FPS. 1440 RPM.  
18 FPS. 1080 RPM.
2. Cam Claw Protrusion MIN. 1.0mm — MAX. 1.2mm (.040" to .045")
3. Claw Pitch 7.64 — 7.67mm
4. Tension of Claw Lever Spring 312-11161  
1.2 — 1.25kg.

Note : Tension of claw lever spring is measured with a tension scale pulling on cam claw and the claw lever spring stretched to maximum.

### B. DISASSEMBLY OF CAM TANK

1. Remove cam tank module as described in sec. 315-4-1.
2. Remove two slotted screws (49), and slide out the still picture clutch lever.
3. Unscrew the screw (47) at the end of the cam shaft (3).
4. Remove shutter pulley (42) and the shutter blade (39).
5. Unscrew three screws (38) and remove cover plate (37). If necessary, turn the shutter blade (39) to expose the screws. The heat filter glass Arm assy. (54) can stay on the cover plate. In reassembling the cover plate, make sure the spring (55) is seated in correct position on the cam housing (1).
6. A hole in the curved plate spring (24) fits over fulcrum control pin (16). Unscrew the screw (25) and remove curved plate spring.
7. Unhook the claw lever spring (33), and remove claw lever assy. (26).
8. To remove cam (10) and cam plate (9), unscrew the three set screws (11).
9. To remove cam shaft assy., remove inching knob (7) and worm gear (5).
10. To replace the cam tank bearings, the inner bearing is pressed on the cam tank shaft and should be replaced as part of the cam shaft bearing assy.  
The outer bearing may be replaced separately.
11. Clean all the old dried molybdenum grease from the cam tank.
12. Avoid using a de-greaser or solvent which may wash the lubricant from the cam shaft ball bearings.

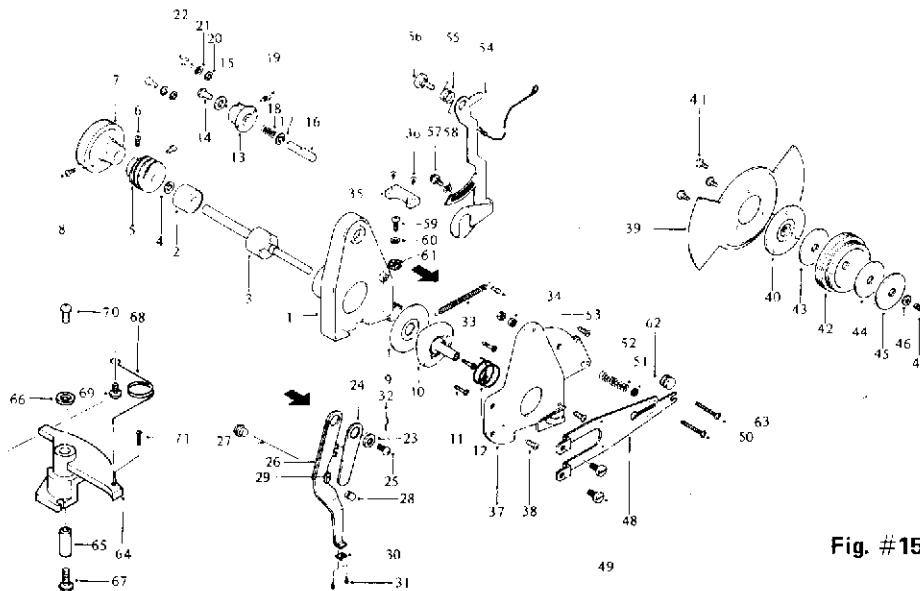

Fig. #15

### C. REASSEMBLY OF CAM TANK BY REVERSING THE ABOVE PROCEDURE

1. Make sure curved plate spring is not jammed between the end of fulcrum pin and washer (23) 312-11681.
2. The cam shaft should have no end play.
3. Worm gear is mounted without any clearance between the cam tank bearing.
4. No end play is allowed in the ball bearings on the cam shaft.
5. When overhauling the cam tank, it is suggested that the felt oil pad be replaced.
6. Re-lubricate the cam area with a small amount of molybdenum disulfide grease and moisten the felt with a few drops of molybdenum oil.
7. If the shutter blade has not been removed from the hub, no synchronization adjustment is required. For correct synchronization see sec. 4-1-F.

### D. ADJUSTMENTS

#### 1. Claw Protrusion

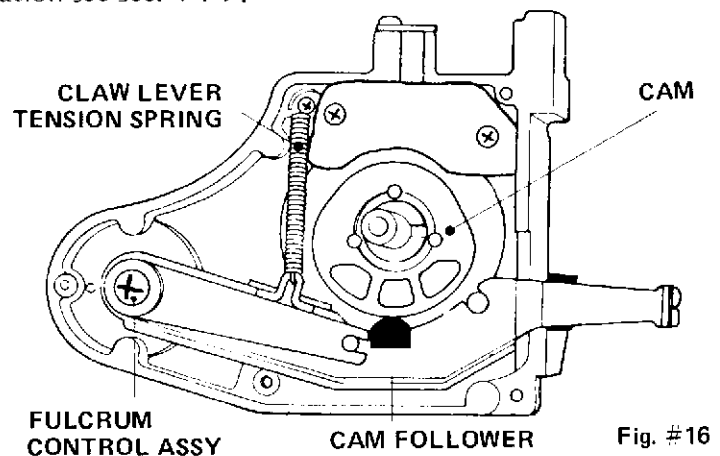

- a. Claw protrusion can be adjusted by the fulcrum collar. As the sliding pin 312-11181 wears, the protrusion will increase.
- b. Loosen set screw (A) by 1/8 of turn as indicated in Fig. #17.
- c. Turn screw (B). Loosening screw (B) (counterclockwise) increases the claw protrusion. Tightening the screw (B) (clockwise) decreases the claw protrusion.

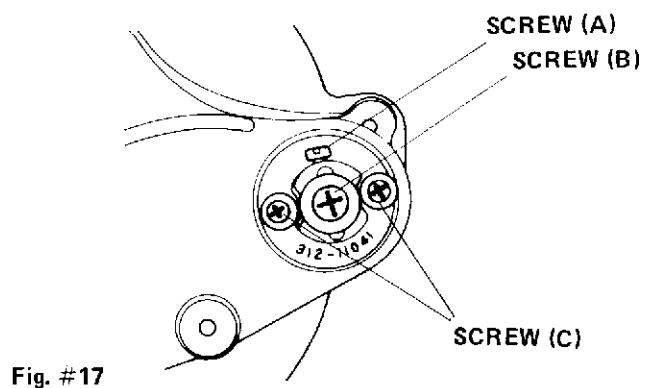

- d. Checking claw protrusion using Tool No. 320-01T (Fig. #18), or equivalent.
- (1) Push the film shoe open until it lock in position.
  - (2) Remove film shoe and bracket assy.
  - (3) Rotate inching knob until the claw is at the top of its stroke. (Maximum protrusion)
  - (4) Attach the tool between the inner guide rail and the outer guide rail.
  - (5) With the edge-side that has the smaller "V" notch and claw protrusion should be enough to touch.
  - (6) Change to the side that has the larger "V" notch and the claw should move freely.

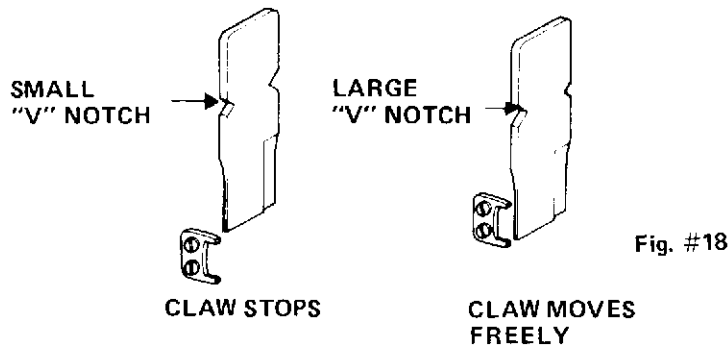

2. Claw Position And Framing Adjustments:

- a. If the claw does not enter the center of the film perforations, or if the framing adjustment is insufficient, the claw position should be adjusted. This adjustment can be either horizontal or vertical. To adjust, slightly loosen the two screws (C) of the fulcrum assy. shown in Fig. #17.
  - (1) Framing Adjustment: This is best accomplished with the projector running, showing a shop test film. With the framing control lever in the up position, the frame bar of the film should appear as in Fig. #19 and in the down position the frame bar should appear as in Fig. #20.



- (2) If the conditions in step 1 are not correct, adjust the vertical or up and down position of the fulcrum assy. by slightly loosening screws (C) (Fig. #17) The fulcrum assy. requires only a very small movement to effect the framing position.  
 Note : If framing range as indicated cannot be reached, check for a worn cam follower (or cam gliding pin. 312-11641) (Fig. #17)
- (3) Check for Correct Claw Alignment With The Sprocket Holes: To view the claws position in the sprocket holes, thread a strip of good film. Remove the film shoe and bracket assy. With a standard 50mm (2") lens installed, look through the lens. Focus and rotate the inching knob while observing the claw position in the film sprocket holes.

Caution : Do not turn on the projector or lamp while looking through the lens.



- (4) Fig. #21 indicates the correct position of the claw just before the start of the pull-down. Fig. #22 indicates the position after completion of the pull down.
- (5) To adjust the claw position, move the fulcrum assy. horizontal and slightly vertical until the distances a, b, c, d are equal as indicated in Fig. #21, #22.  
Upon completion of the position adjustment, tighten the fulcrum assy. screws and re-check the framing range with the projector running.

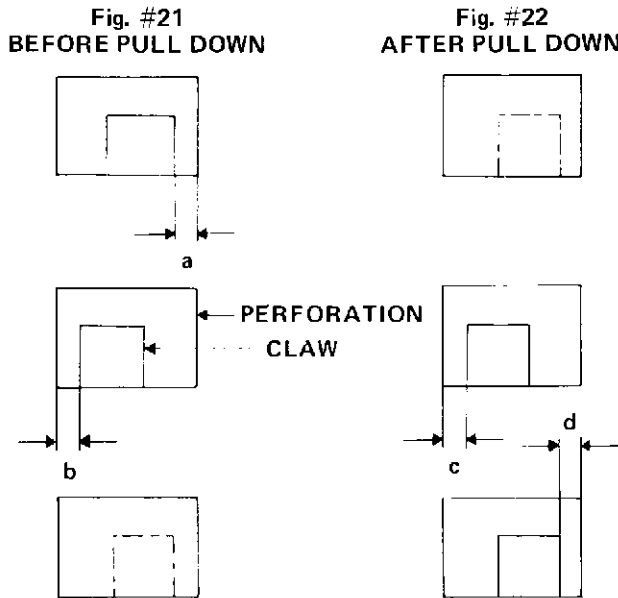

### E. REPLACING THE CLAW

When replacing a worn or defective claw, it is important to mount the claw correctly before securing the mounting screws. Incorrect claw mounting may result in excessive film gate noise or unsteady picture.

International Dimension of the 16mm Film Fig. #23

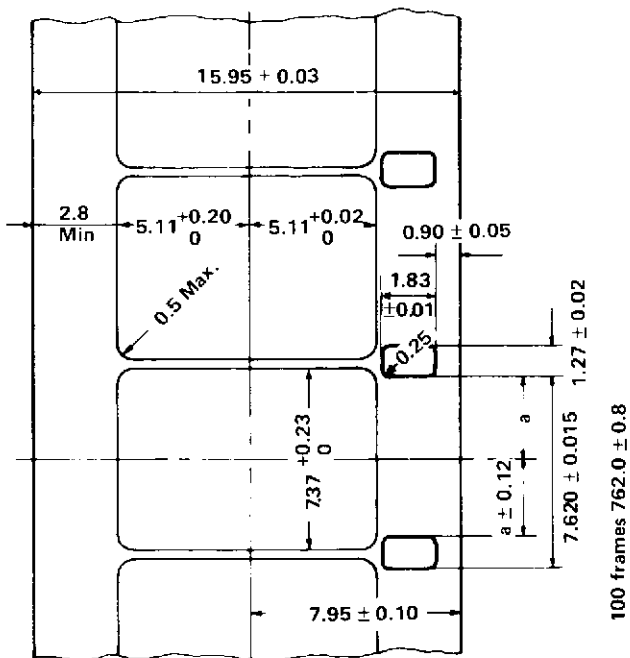

## 1. Correct Claw Pitch

- The international dimensions of the 16mm film are shown in Fig. #23. Claw pitch is set at 7.64 – 7.67mm. A pitch less than 7.64mm will cause the claw to engage the film between perforations possibly causing film damage or unsteady pictures.
- A pitch more than 7.67mm will cause excessive gate noise. Typical film perforation should have a pitch of 7.605 – 7.635mm, but older films may have a smaller pitch due to shrinkage.
- The claw as shown in Fig. #24 has a 5° angle at the top tooth, and should the claw pitch become larger than the pitch of the perforations, this would help prevent any film damage.

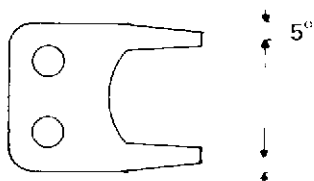

Fig. #24

## 2. Adjusting of The Claw Pitch

- Moving the fulcrum control assy.: Fig. #25 shows the correct position between the cam and the cam follower (cam gliding pin, 312-11641). The contact point of the cam follower with the cam will change the pitch. Moving the fulcrum control assy. to the left decreases the pitch and moving it to the right increases the pitch.

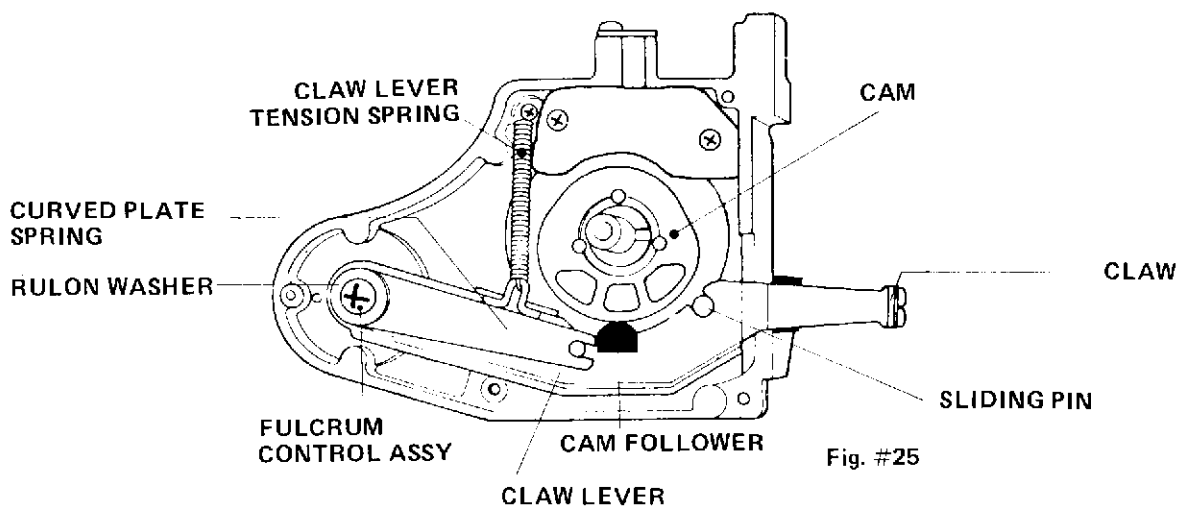

Fig. #25

- The fulcrum control assy. should only be moved slightly. Too much adjustment will cause the claw to hit the sides of the film perforations causing film jitter.
- Correct claw angle is shown in Fig. #26-A. Under some circumstances a bent claw lever as shown in Fig. #26-B and -C may have to be corrected by straightening out the claw.

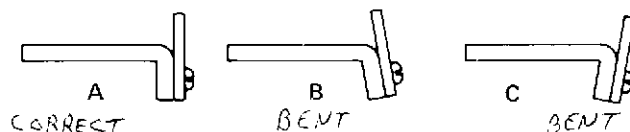

Fig. #26

### 3. Claw Lever Tension

(See Fig. #25)

The claw lever tension force should be from 1.2 to 1.25kg when the spring is stretched to the maximum travel of the claw lever arm. If the tension is too weak, the cam follower may float off the cam surface causing excessive gate noise and an unsteady picture. On the other hand, if the spring is too strong the cam follower may wear out prematurely or cause a slight hesitation to the claw lever when the projector is initially started. To obtain the correct tension it may be necessary to replace the spring. A slight adjustment can be made by stretching the spring if necessary.

### F. CHANGING SHUTTER BLADES

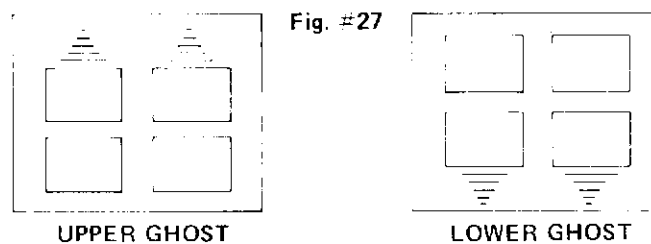

Two, three and five bladed shutters can be mounted on the shutter hub. The mounting holes used to secure the blades to the hub allow a small adjustment for shutter blade timings. Incorrect shutter timing results in what is commonly called "travel ghost". The adjustment is accomplished using the SMPTE test film and adjusting the blade position for minimum upper or lower image movement as shown in Fig. #27. Since the adjusting screws are only accessible with the cam tank removed, this becomes a trial and error adjustment. However, the skilled technicians can accomplish this in one or two adjustments.

When mounting a 2 blade shutter to the center hub, the recessed circle of the blades must be toward the side where the 3 mounting screws are located.

The relationship of the shutter blade to the indexing semicircle on the hub must be as illustrated in Fig. #28. 3 blade shutters will always index correctly.

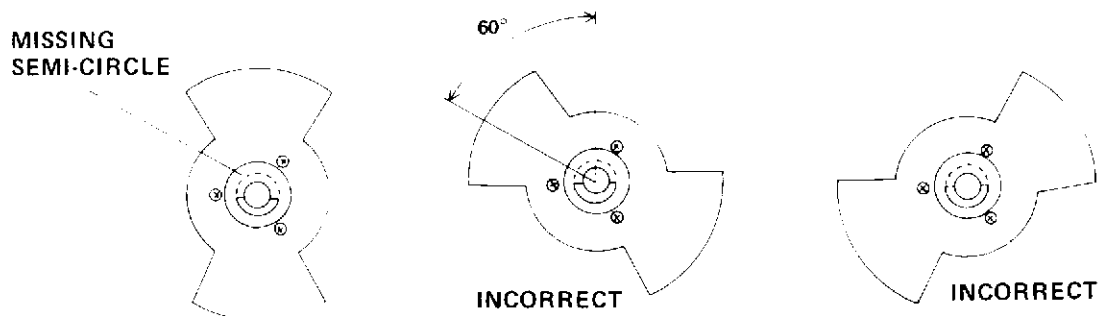

Fig. #28

## G. STILL-RUN CLUTCH

### 1. Description:

The still picture control "RUN-STILL" (30) is spring loaded and snaps into position when operated.

When placed in the still mode the wire cable tension is released, dropping the (54) heat filter in front of the projection lamp.

At the same time the "RUN-STILL" lever moves the shutter (39) and clutch hub assembly away from the shutter pulley (42), disengaging the shutter blade and cam shaft.

The shutter pulley (42) is now free to rotate on the cam shaft without turning the camtank mechanism.

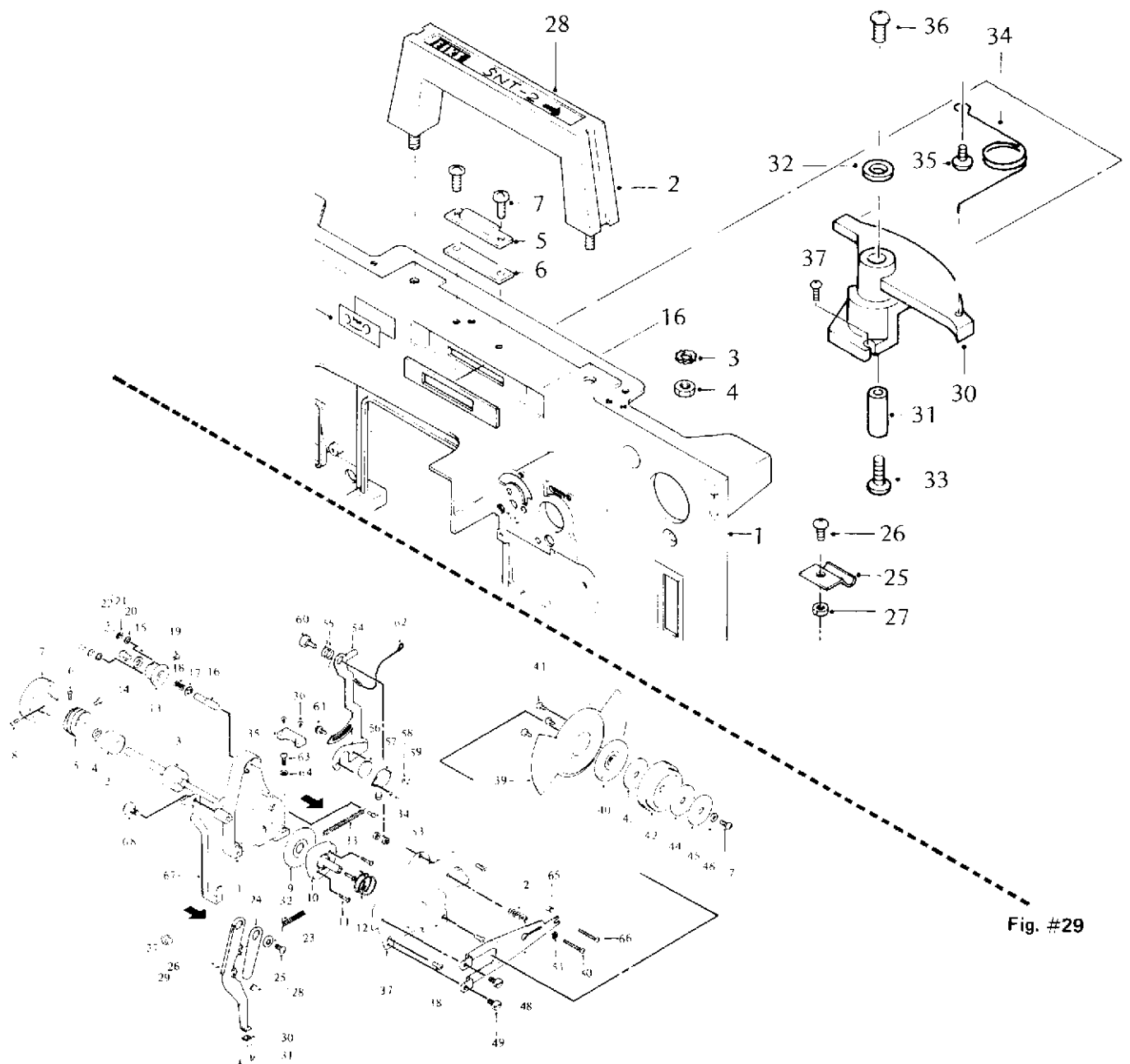
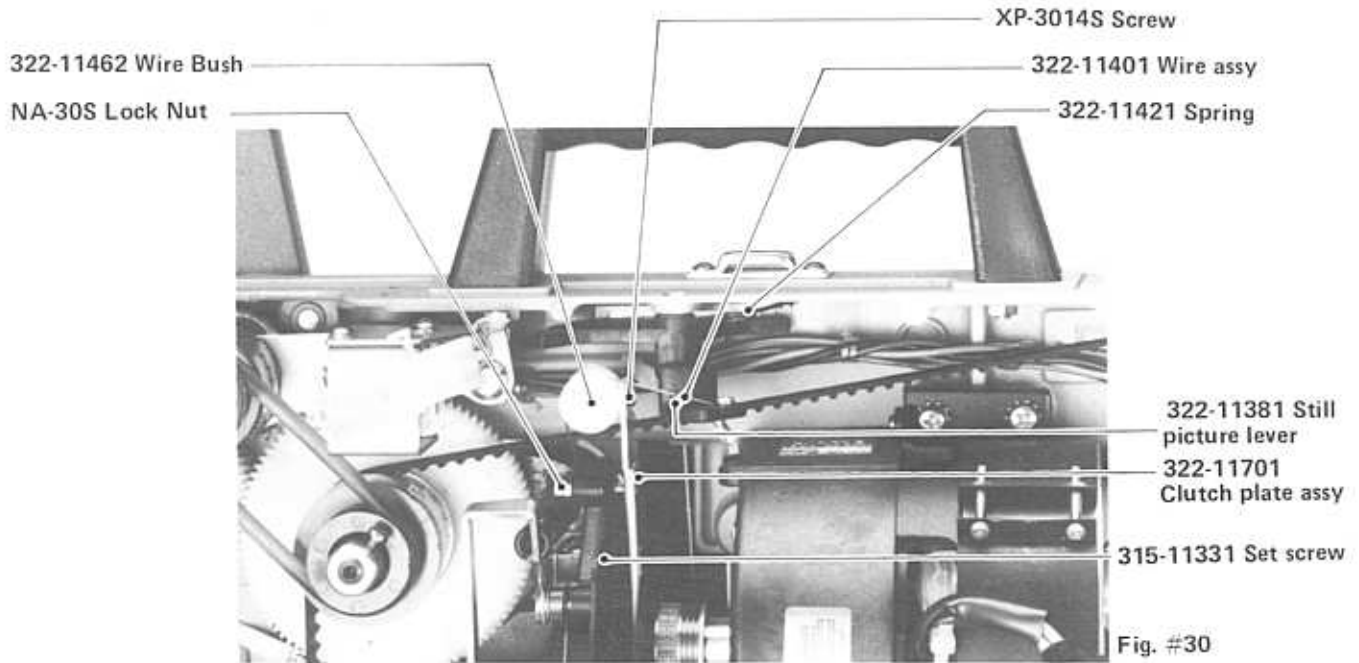
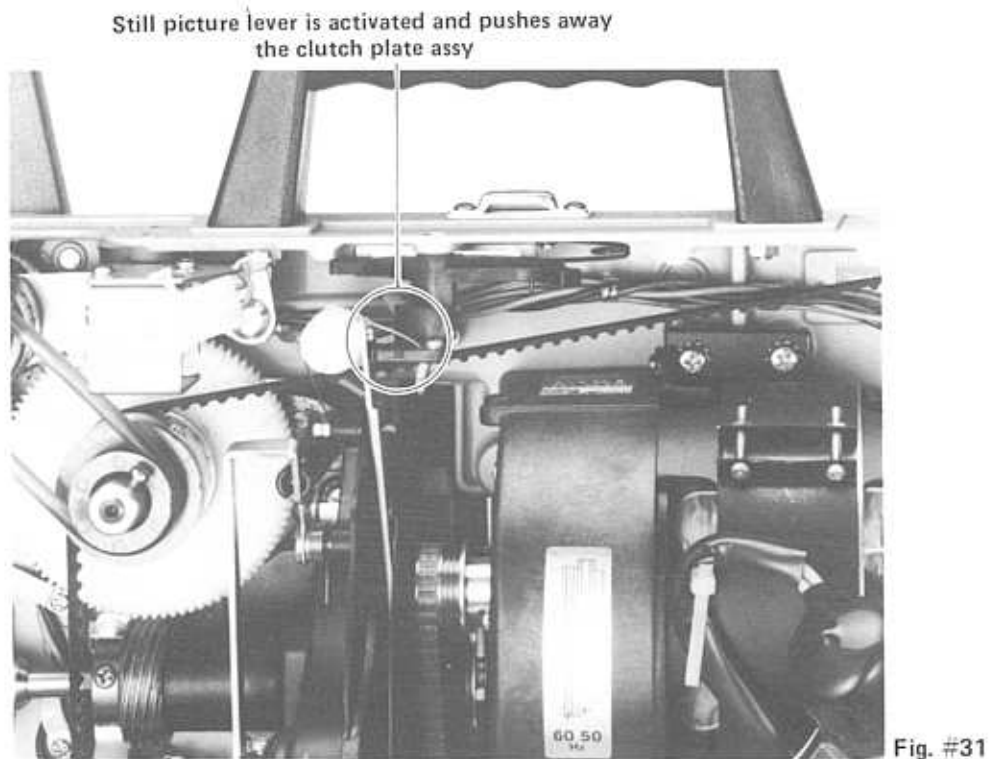

Fig. #29

## Still Picture Clutch in "RUN" Position



## Still Picture Clutch in "STILL" Position



2. Adjustment:

- (a) In the run position the spacing between the clutch lever and the inside flange of the shutter hub should be approximately 0.2mm (see Fig. #32). Adjust the set screw (315-11331)

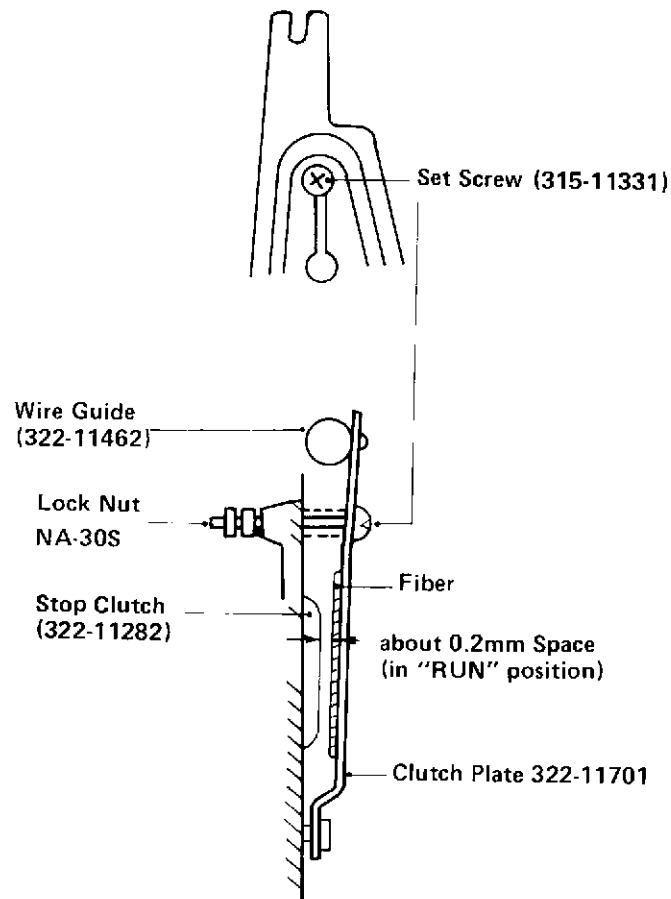

Fig. #32

for correct spacing and secure the jam nuts. The above adjustment is critical for proper clutch action. If the space is too large, the clutch will not release in still and if the space is smaller, the clutch will slip in run.

- (b) The correct position of the heat filter is determined by the cable tension. In the run position the cable is tight, holding the heat filter above the aperture opening. Adjust the white duracon wire guide position to insure that the heat filter is clear of the optical path (see Fig. #33)

The angle of the wire guide should also be adjusted so as to provide a straight pull to the heat filter lever.

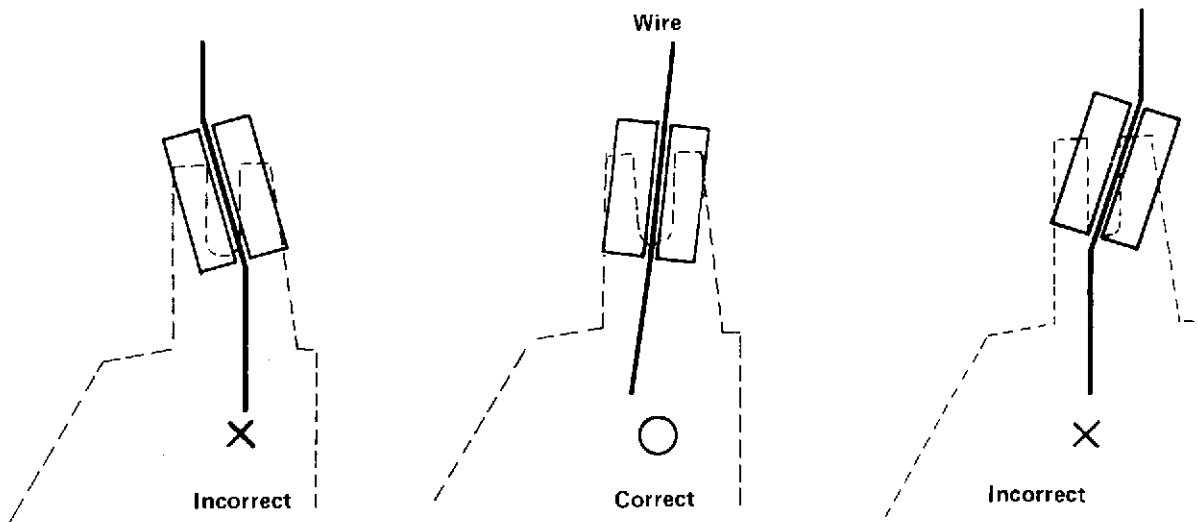
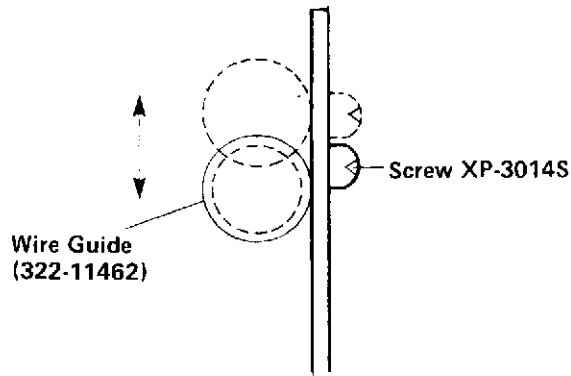

Fig. #33

Correct Angle of Wire Guide

The heat filter lever is spring loaded and in the still position the cable should provide sufficient slack to allow the heat filter to drop in front of the lamp.

- (c) The above adjustments should be checked whenever a cam tank module has been removed and re-installed.

## 5-2 : AMPLIFIER MODULE

Refer to Amplifier Circuit Diagrams for the following:

### A. Specifications

1. Solid State, "2" IC and "8" transistors
2. Output Power: 25 watts RMS 8 ohm load
3. Distortion: Less than 5% at 400Hz  
Less than 3% at 1KHz
4. Wow & Flutter: Less than 0.2% WRMS.
5. Frequency Response: Optical 50Hz – 7000Hz  $\pm 4$ db  
Magnetic 50Hz – 12000Hz  $\pm 4$ db
6. S/N ratio of the amp: 60db
7. MIC input impedance: 600 ohm and up (Hi Z)
8. MIC input level: 10mv max.
9. Speaker Jacks: 8 ohms
10. Aux output: 600 ohm un-balanced –20db to 0db (1.4V)  
10K ohm +19db (7.0V)

### B. Amplifier Power Supply Circuit

AC power to the amplifier is supplied from the 46V AC secondary windings of the transformer through pins #1 & #2 of the 9 pin socket (MT-9P), dual diodes D-4 & 5 bridge rectifier, filtered by capacitor C-35 providing the amplifier voltage of approximately 62V DC. The 8V AC transformer secondary winding supplies AC exciter lamp voltage through pins #4 & #5 of the 9 pin socket. Dual diodes D-6 & 7 form a bridge rectifier which is filtered by capacitor C-36, C-37, and C-38. Zener D-3 provide a base reference to TR-7. R-42 is a current sense resistor serving as feedback to TR-8's base. TR-7 acts as a series regulator with a voltage sense from TR-8 to maintain the 3.5 volt to 4 volts. DC Exciter Lamp voltage is routed through pins #8-9 of 9 pin socket to the exciter lamp.

In magnetic playback the base input voltage to TR-7 is held at 0V, turning TR-7 "OFF".

### C. Audio Amplifier Circuit

The input from the solar cell or magnetic head is accomplished through the 5 pin connector and switched to their appropriate impedance loading circuit. Models with optical sound capabilities only have amplifiers without the opt/mag switch. The input signal is routed through the MIC jack and coupled to IC-1 (AN-370) via capacitor C-3 and resistor R-6.

R-8, 9 and 10 C-8 and 9 form the opt/mag input equalization network, with feed back from the tone controls VR-1 and VR-2.

Tone control equalization is accomplished by R-13, 14 and 15 and capacitors C-13, 14, 16 and 17.

From the tone controls the signal is coupled to the pin 2 of IC-2 (AN-370) via C-18 and R-15, and IC-2.

The output of IC-2, pin-6 is coupled through C-23 and R-20 to VR-3 (volume control). The wiper of VR-3 is coupled through C-25 to the base of TR-1 amplified and coupled to the base of TR-2, from TR-2 the signal is phase split to intermediate drivers TR-3 and TR-4 respectively. The final complimentary drivers TR-5 and TR-6's emitter are coupled to R-36 and R-37 through C-33. The final driver to the speaker jack is from the negative side of C-33 and ground. Note that the output to the rear cover speaker jack is switched through the external speaker jack.

600 ohm un-balanced aux line output is available through the external speaker jack provided a "stereo" 3 conductor phone plug is used.

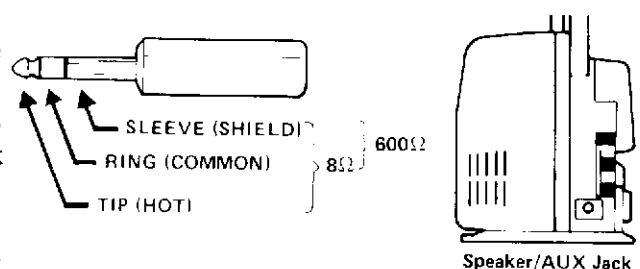



5-3 : MOTOR MODULE

A. SPECIFICATION

1. AC Induction type
2. 1/20HP
3. 100-120V, and 220-240V
4. Power consumption 144 – 168W (120V, 1.2A), or (220, 240V 0.7A)
5. Starting Torque: 1.6kg/cm
6. Rated Torque: 0.8kg/cm

B. MOTOR CIRCUIT DIAGRAM

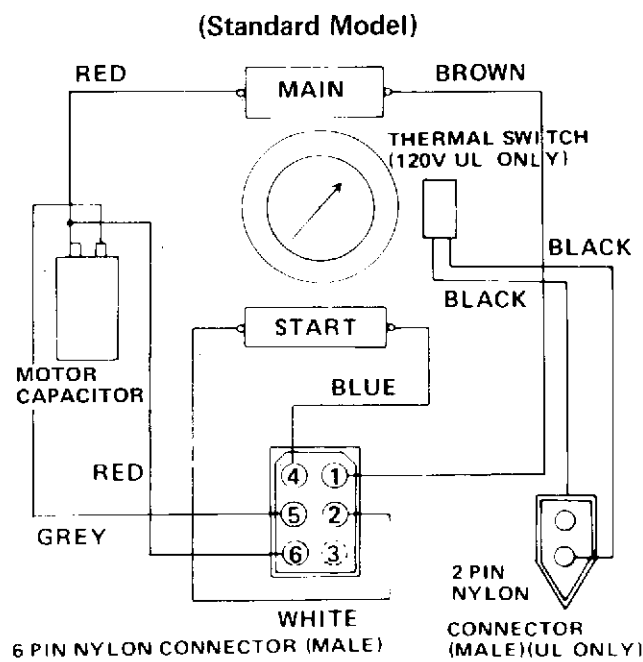

Fig. #37

### C. SILENT FILM OPERATION AND 50/60HZ CONVERSION

SNT/ENT Standard models are provided with 50/60Hz sound only (24 FPS) speed. To convert from 50Hz to 60Hz, or vice versa, remove the rear cover, and while turning the inching knob, guide the motor belt to the desired position. (Fig. #38) (Fig. #39)

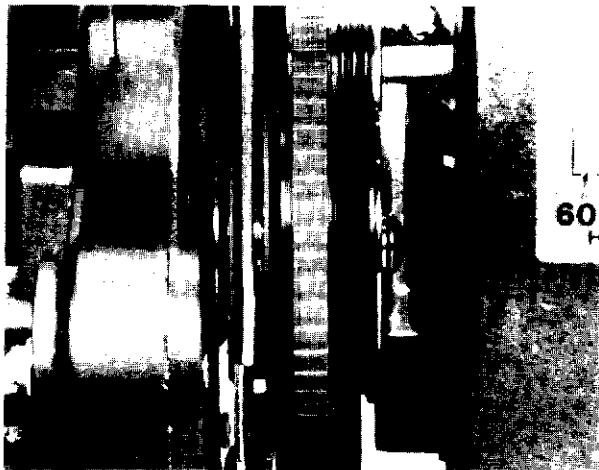
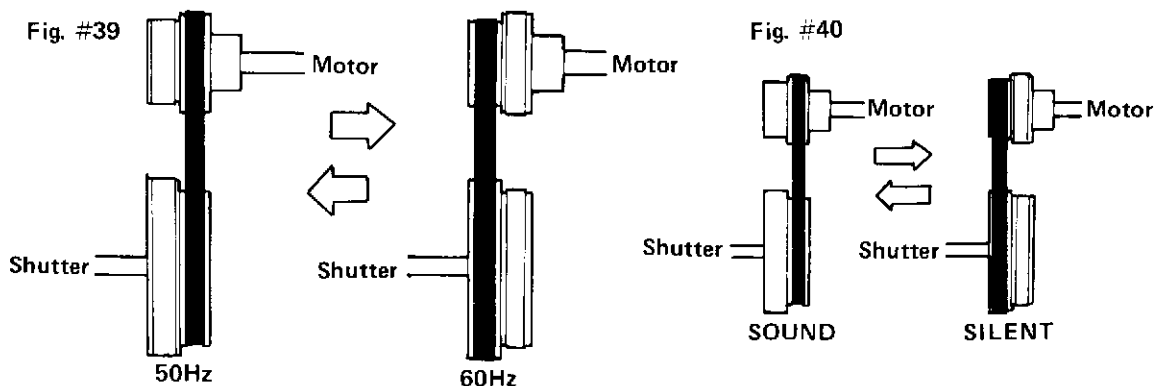

Fig. #38

As an option, 18/24 FPS 50Hz, or 18/24 FPS at 60Hz models are available. To convert from 18 FPS to 24 FPS or vice versa, follow the same step as above. (Fig. #40)



The chart below will assist in selecting the proper pulley combination.

| OPERATION   | MOTOR PULLEY ASSY | SHUTTER PULLEY ASSY | MOTOR BELT |
|---|-------------------|---------------------|------------|
| 100/110/120V or 220/240V<br>50/60Hz sound only 24 FPS     | 322-12101         | 322-11872           | 322-12181  |
| 100/110/120V or 220/240V<br>60Hz sound & silent 18/24 FPS | 322-12401         | 322-11852           | 322-12181  |
| 100/110/120V or 220/240V<br>50Hz sound & silent 18/24 FPS | 322-12501         | 322-11862           | 322-12181  |

5-4 : TRANSFORMER MODULE

Secondary Windings

- 1 – 3 : Halogen Lamp 24V Hi.
- 2 – 3 : Halogen Lamp 22V Low.
- 6 – 9 : Amplifier (46V)
- 7 – 8 : Exciter Lamp & Pilot Lamp (8V)

Wires Coloring of 9P Connector

- 1. Black
- 2. Blue (or Grey)
- 3. Brown (ENT only)
- 4. Black (ENT only)
- 5. White
- 6. Yellow
- 7. Red
- 8. Red
- 9. Blue

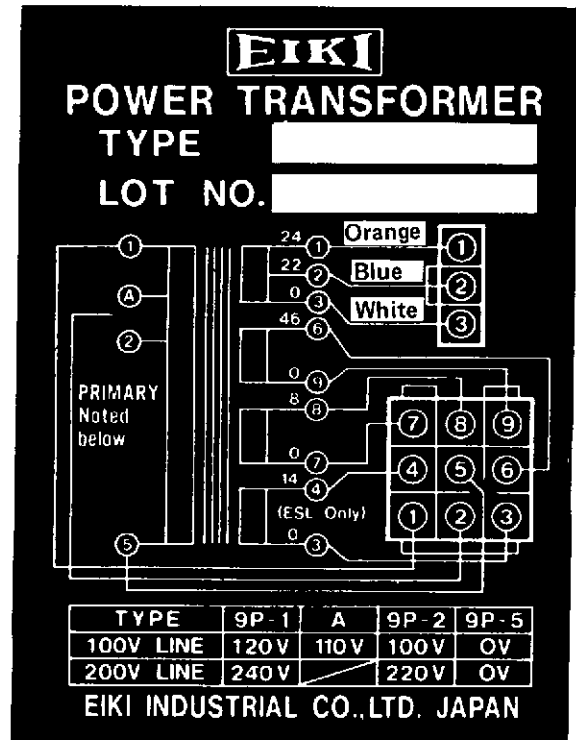

Fig. #41

5-5 : FILM SENSOR SYSTEM

A. Description:

The rewind function is locked out when the film is in the threading path. Sensor roller (7) drops into guide roller (10) Fig. #43, when no film is in the threading path, closing microswitch (37) to activate the rewind solenoid, when ever the function switch is in the reverse/rewind position.

The presence of film between the sensor roller (7) and the guide roller (10) Fig. #44 maintains the microswitch (37) open preventing accidental activation of the rewind function while the film is threaded.

On ENT models the sensor roller (7) is also used to signal the timer circuit which automatically stops the film threading after approximately 70cm (2 feet) of film has passed through the threading path.

B. Adjustment:

The microswitch actuator should be adjusted such that the microswitch is off (open) at all times except when the sensing roller (7) drops below the film plane level of the guide roller (10) at which point the microswitch should be on (closed).

It is important that the rollers move freely and the sensing roller moves up and down with the lightest touch. (see Fig. #45). The position of the sensing roller must also allow the roller to drop freely into the cut portion of the guide roller. Make sure that rollers are clean and free from any dirt, dust or old film emulsion, which may prevent the rollers from activating freely.

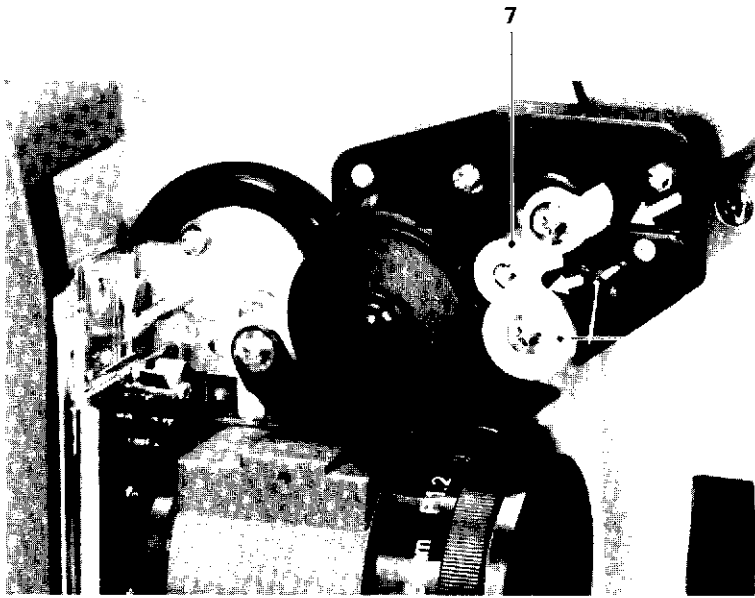
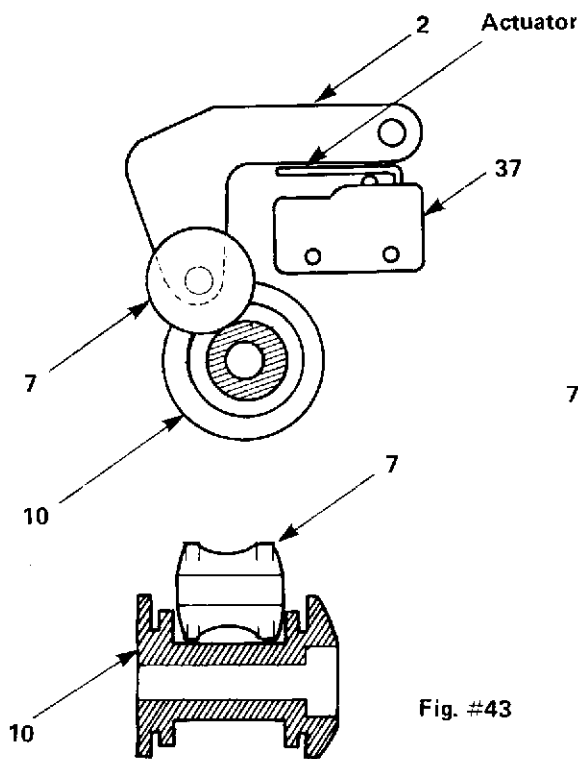
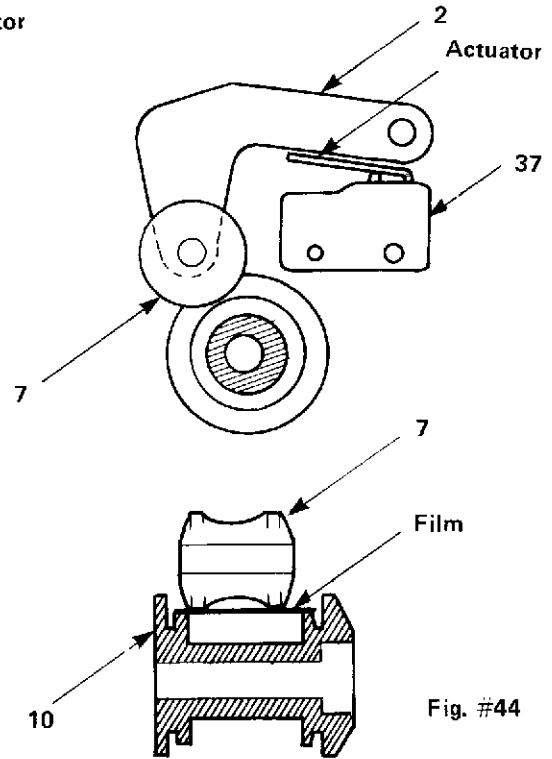

Fig. #42



No film in the threading path  
Sensor micro switch (37) ON



Film in the threading path  
Sensor micro switch (37) OFF

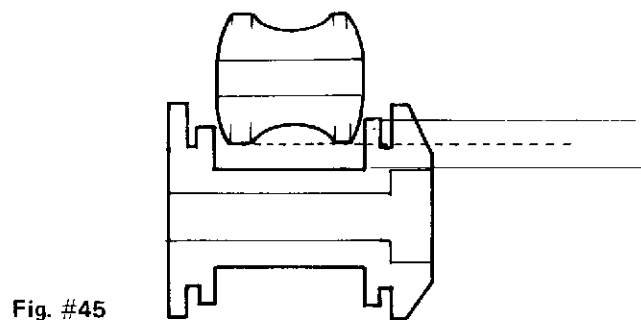

Fig. #45

## 5-6 : FILM GATE ASSEMBLY

### A. Description

The aperture plate (4) is mounted on the gate plate (1) by two nuts and can slide up and down for framing adjustment. The outer guide rail (8) is fixed to the gate plate by two screws. The movable inner guide rail (12) is mounted by two shoulder screws and adjusted by the side pressure spring (14). The side pressure control lever (10) is linked to the film threading mechanism controlled by the self-thread lever opening and closing the inner guide rail.

### B. Adjustment

#### 1. Tension of the Side Pressure Spring

The proper tension is about 60 – 75g. Excessive tension will cause earlier film wear, while insufficient tension causes an unsteady picture. The adjustment of tension can be made by bending or straightening the spring. A weak or incorrectly formed spring should be replaced.

#### 2. Outer Guide Rail Position

When the film is loaded, the center of the film should align with the center of the aperture. To accomplish this, adjust the position of the outer rail.

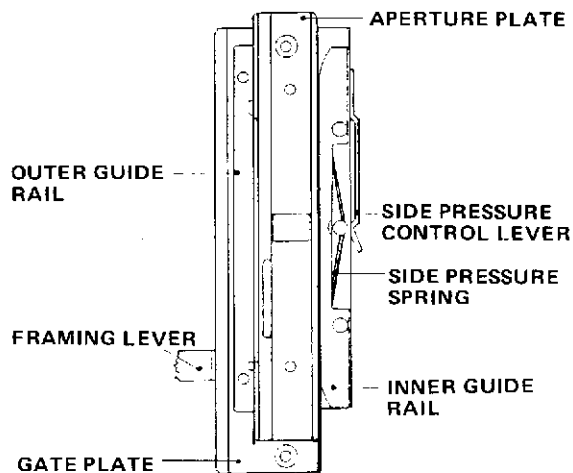

Fig. #46

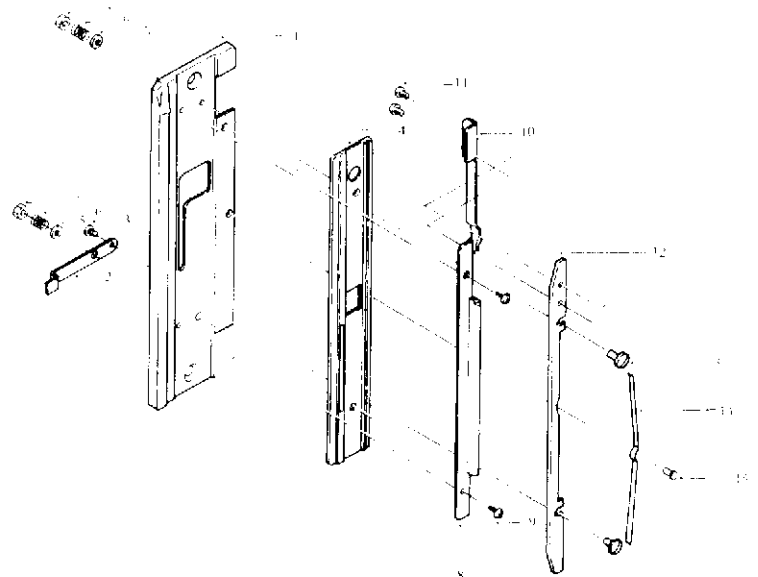

Fig. #47

5-7 : Film Shoe And Bracket Assembly  
 A. Description

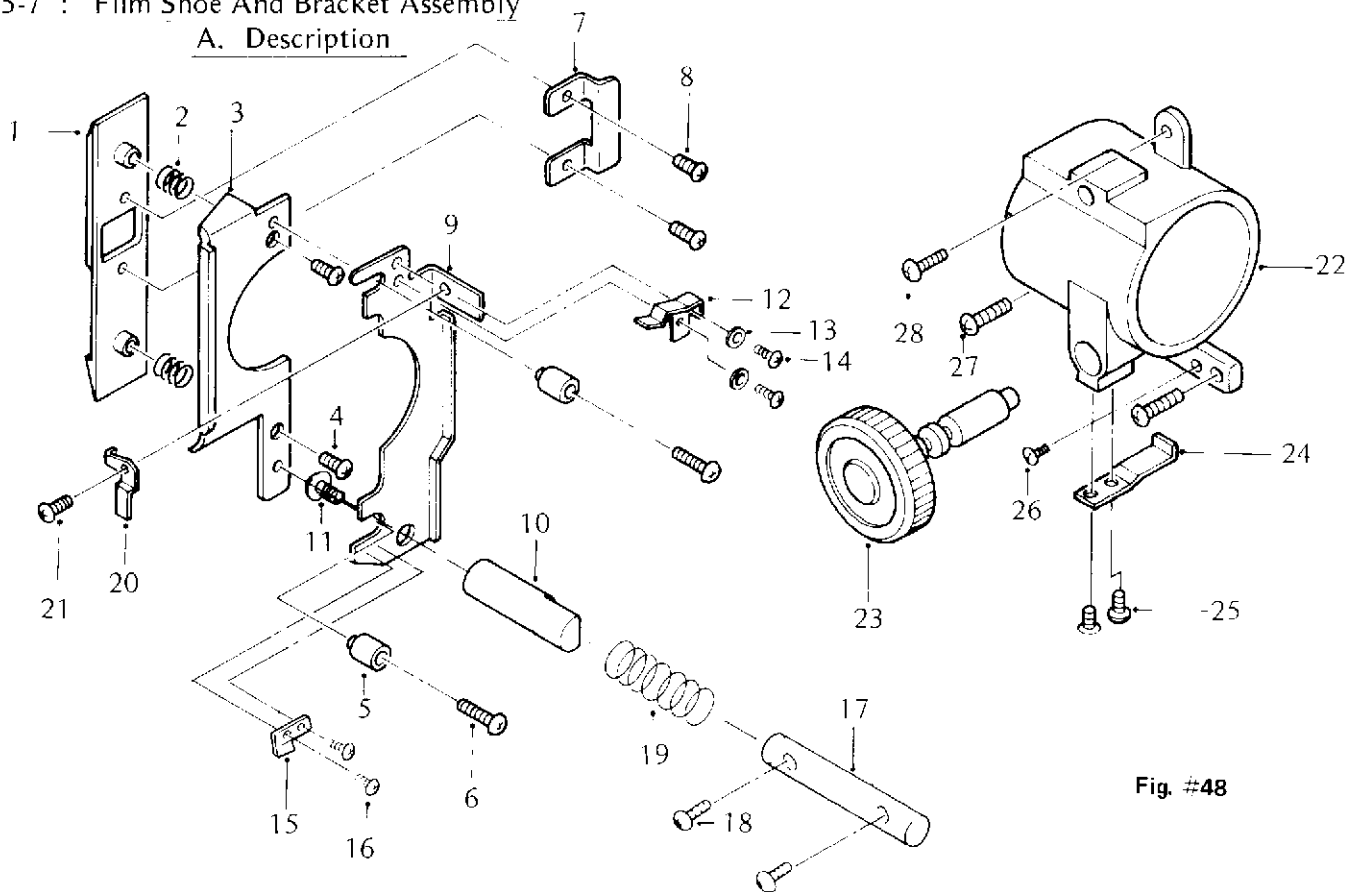

Fig. #48

Removable Film Shoe and Bracket Assembly

The spring loaded film shoe (1) is mounted to a bracket (3) and is easily removable as an assembly for cleaning and servicing the film gate.

The film shoe and bracket assembly is then seated in the reception bracket (9). The reception bracket is linked to the threading mechanism which opens and closes the film gate when the self-thread lever is activated.

B. Adjustment

1. Uneven Focus

Uneven focus occurs whenever the image of the film is not flat and perpendicular to the optical path of the lens. Since the lens holder assembly is mounted directly on the projector's casting, any adjustment would have to be as a result of improper mounting of the Lens Holder.

To compensate for small tolerance differences in the projector's main casting, the lens holder bracket is fitted with 2 small set screws. When removing or replacing the lens holder assembly, careful adjustment of the set screws for even side to side focus is required.

When performing this procedure, projector must be absolutely perpendicular to the viewing screen and the lens focused for a sharp center image.

It is a good idea to use a test film with a continuous pattern since many production films purposely use out of focus images to achieve special effects.

Loosen the small phillips screws and adjust the set screws to obtain an even focus condition then secure the small phillip screws.

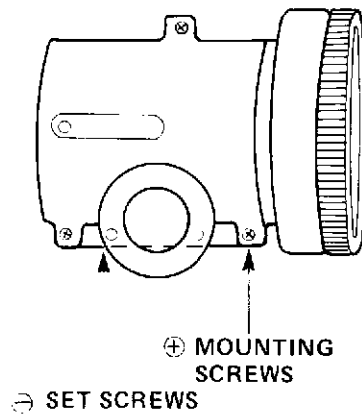

Fig. #49

## 2. Film Shoe Pressure

The pressure of the film shoe against the film is maintained by two small tension springs between the shoe and the mounting bracket. Excessive tension will cause unnecessary film wear, and insufficient tension can cause an unsteady picture, excessive film gate noise and uneven or erratic focus. To test the film shoe pressure, insert a strip of film in the gate, close the gate. Attach a gram scale to the end of the film at the top. A gentle but steady pull should produce about 90 to 110 grams of pull, indicating the correct film shoe pressure. To adjust this pressure, stretch, shorten or replace the shoe springs.

## 3. Film Shoe Position

With the gate closed, the film shoe should line up along the edge of the outer guide rail and seat evenly against the aperture plate. To adjust the position of the film shoe, close the film gate by lightly pushing down the self-thread lever. Loosen the two screws (6) and align the film shoe with the outer guide rail, making sure that the shoe is flat against the aperture plate and secure the screws (6).

5-8 : FILM GUARD (ENT series only)

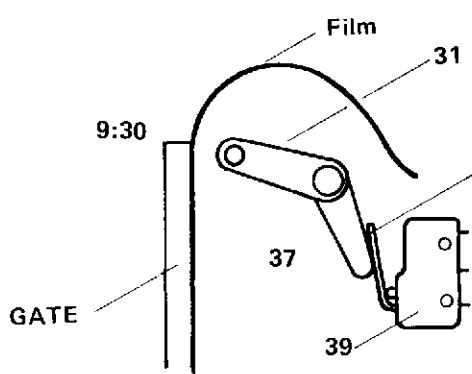
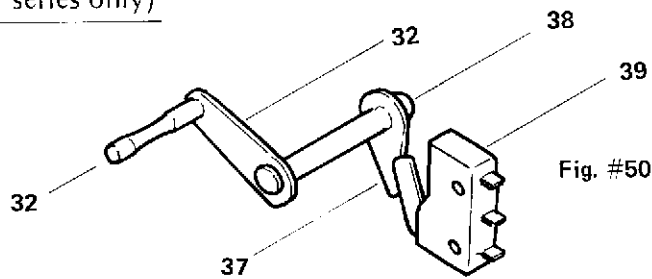
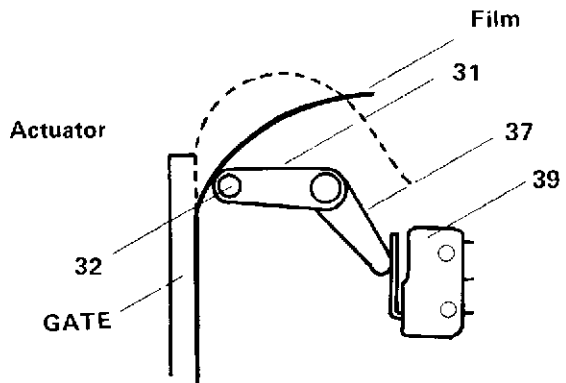

Fig. #51 Film Guard Switch OFF



Film Guard Switch ON Fig. #52

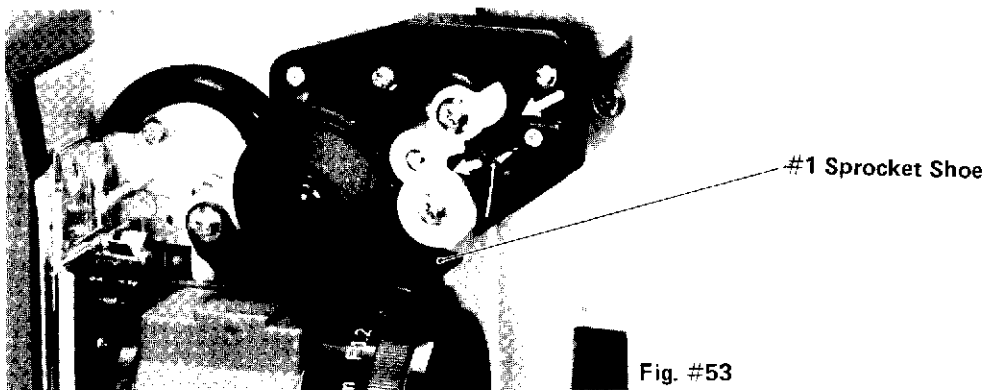

Fig. #53

A. Description:

The film guard switch shuts "off" the power when the upper loop is lost due to severely damaged film or poor quality splices.

In either forward or reverse the loss of the upper loop will cause the film guard sensing lever (32) Fig. #52, to activate the microswitch (39) stopping the projector. To re-start the projector open the #1 sprocket shoe (Fig. #53), reform the upper loop and close the sprocket shoe. Push the "forward" and "lamp" function controls to re-start the projector.

B. Adjustments:

The correct position for the film guard sensing lever is at about 9:30 o'clock (see Fig. #51) when not activating the microswitch which is normally closed. To adjust this position as shown in Fig. #51 loosen screw (38) and adjust the sensing lever until the correct position is achieved and tighten screw (38). A correctly adjusted sensing lever should trip the micro-switch with light downward pressure causing the microswitch to "open" turning "off" the projector.



# 315-6: GENERAL MECHANICAL SERVICING & ADJUSTMENTS

## 6-1 : TAKE-UP ARM A. Description

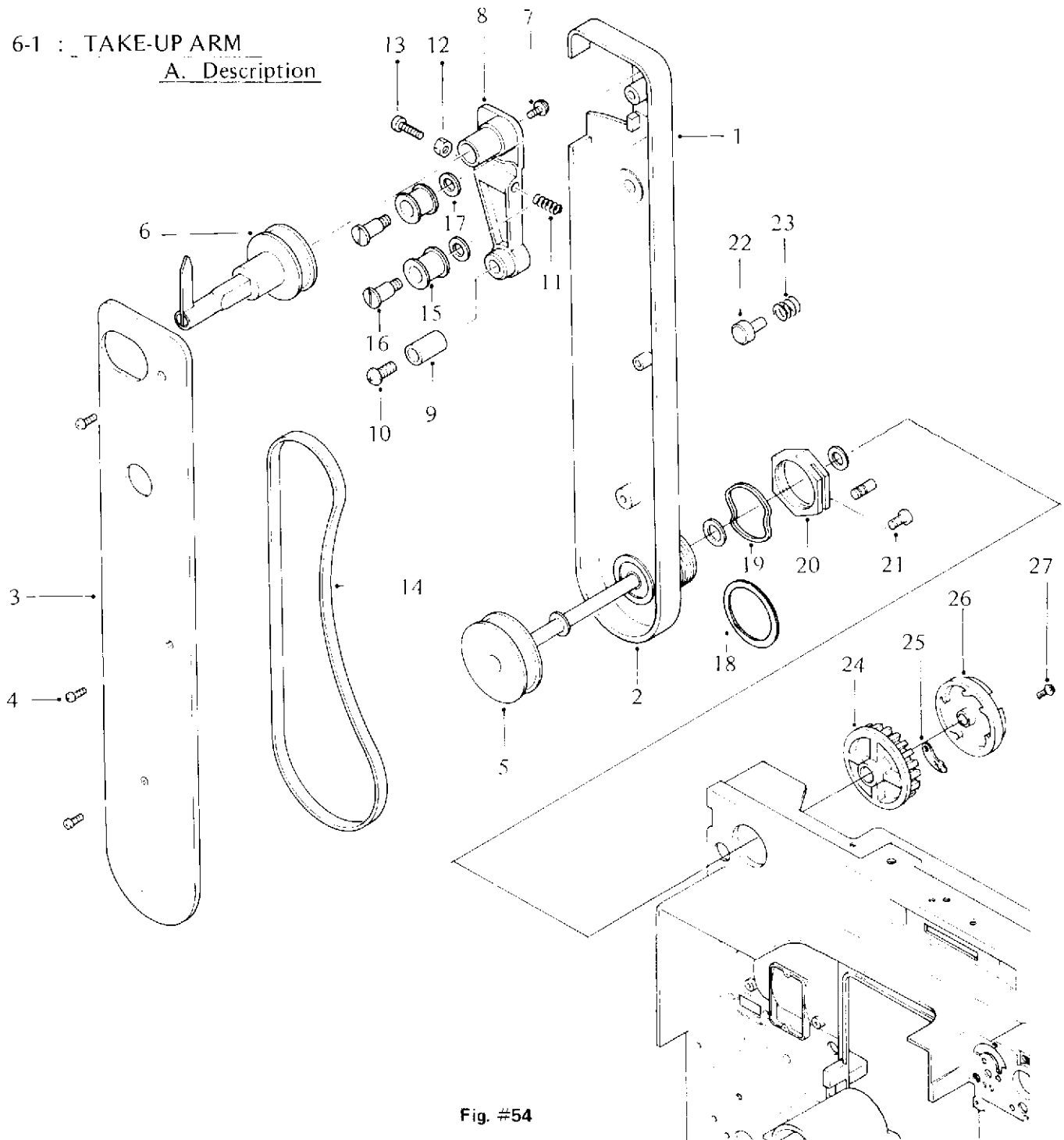

Fig. #54

The drive to the take-up arm is obtained through the take-up clutch mechanism (items 24-27) during normal forward projection. During Rewind/Reverse the motor is reversed, disengaging the clutch cam (25) removing all drive to the take-up arm. In forward the drive is transmitted via the drive pulley (5) to the arm belt and the take-up spindle (6). The amount of take-up torque is controlled by the friction of the belt against the pulley (5) and spindle pulley (6). The amount of friction is adjusted by a combination of the tension spring (11) and the weight of the take-up reel.

## B. Adjustments

### 1. Take-Up Torque

The take-up arm belt must be kept clean with the blue side of the belt positioned towards the pulleys. Avoid any oily substances on the belt. Clean the belt with Isopropyl Alcohol. The take-up tension is adjusted by increasing or decreasing the belt tension with the adjustment screw (13). This tension should have a range from approximately 90 grams to 150 grams, depending on the reel size. Torque in excess of 150 grams should not be permitted on small film reels. Under normal operation where small to medium size reels are used, the tension screw should be adjusted to where it barely makes contact with the tension spring (1mm to 3mm). Clockwise adjustment increases the take-up torque. Counter clockwise adjustment decreases the take-up torque.

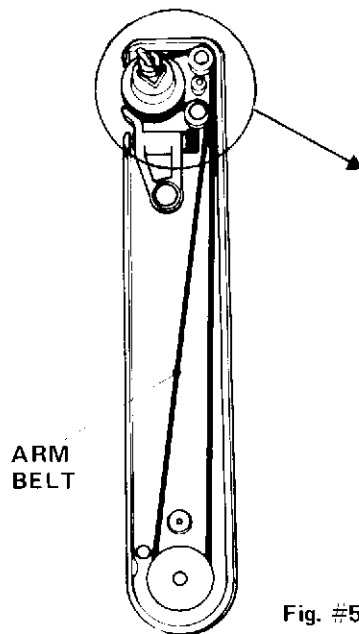

Fig. #55

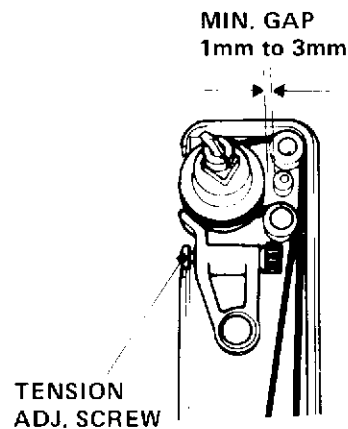

Fig. #56

### 2. Take-Up Clutch Mechanism

The take-up clutch mechanism requires no lubrication. The clutch cam, clutch cover and should be kept clean and free from dirt. A small amount of silicone oil on the drive pulley shaft is sufficient.

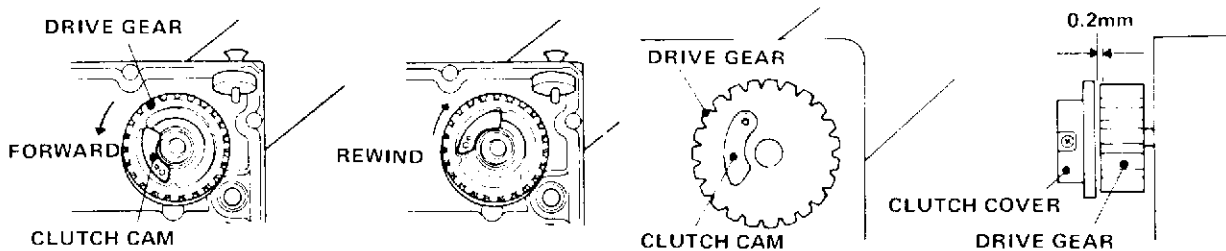

Fig. #57

To Adjust,  
 1. Remove the rear cover.

2. Remove the AC cord storage bracket and expose the drive gear and clutch mechanism.

CAUTION : This screw XT-3008S (Fig. #58) is locked by the nut and washer behind the storage bracket fixing the AC cord clip. Do not drop the nut and washer.

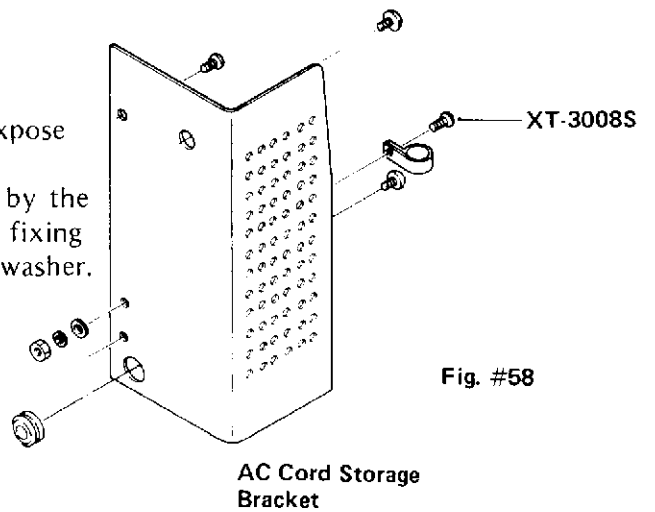

Fig. #58

## 6-2 : SUPPLY ARM

### A. Description

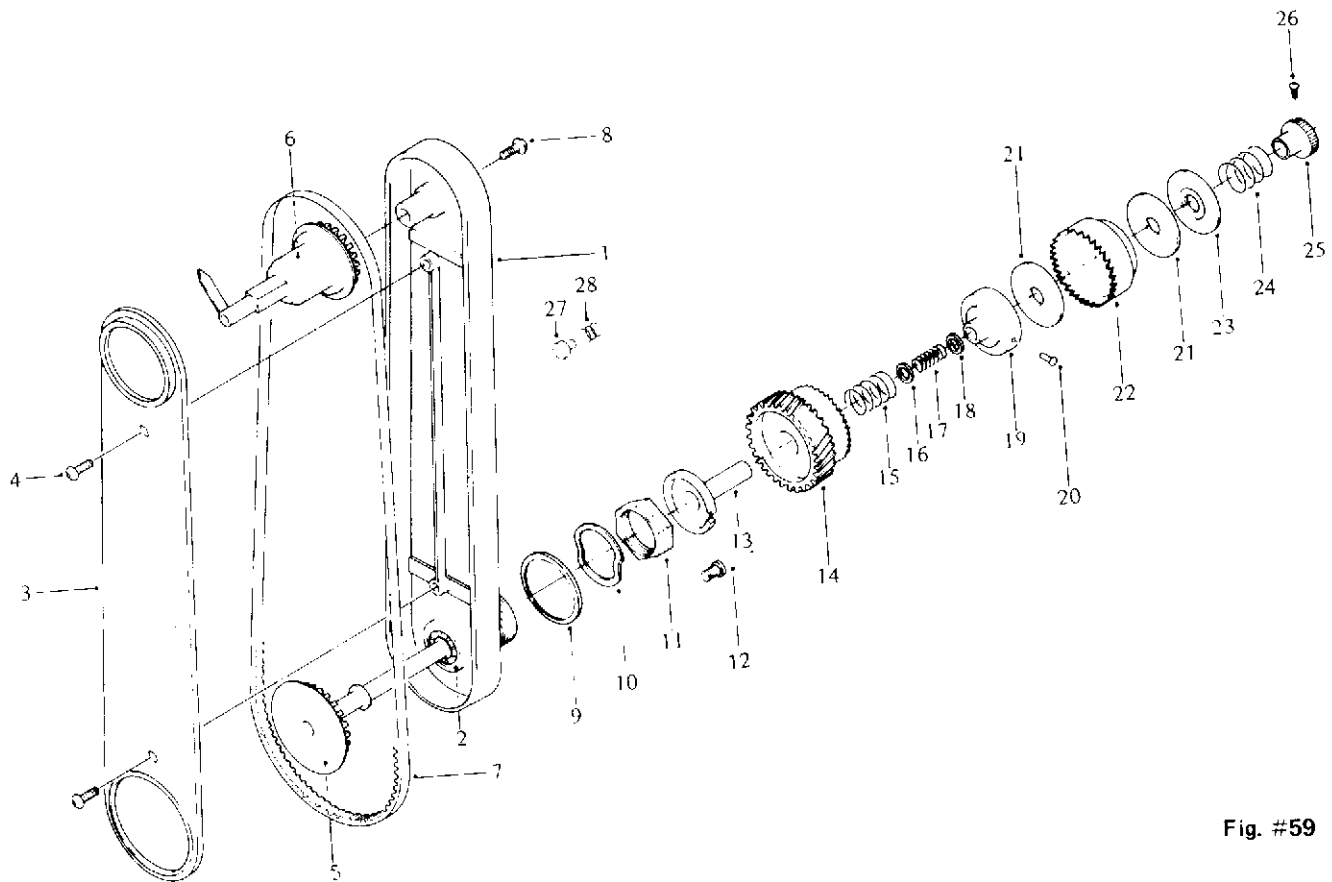

Fig. #59

During forward the supply arm only serves as a drag to provide a small amount of back tension to the film. The amount of back tension is controlled by spring (17)'s tension. For a more complete description of the supply arm, refer to the rewind section.

### B. Adjustments

— None —

### 6-3 : LOWER LOOP SETTER SYSTEM

#### A. Description

Torn or damaged sprocket holes in a film will cause the lower loop to be shortened. When this occurs, the film pull down will be out of sequence with the shutter causing a jitter or jumping picture. When this occurs the automatic loop setter will reset the lower loop again bringing the film under control of the pull down mechanism.

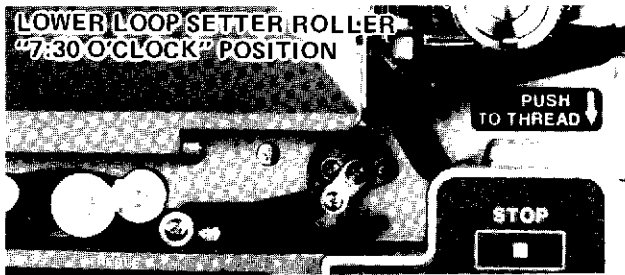

Fig. #60

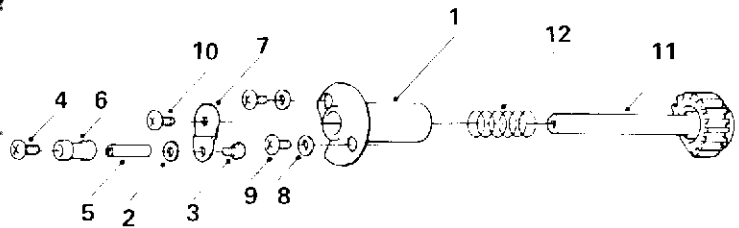

Fig. #61

The automatic loop setter consists of the loop setter roller (6), the hub assembly (1) and the gear and shaft assembly (11). When the lower loop is shortened one complete frame or more, the film applies pressure on the setter roller (6) which in turn causes the eccentric gear (11) to engage, rotating the setter roller one complete revolution, pulling down on the film thus reestablishing the correct lower loop. Additional rotations may indicate severely damaged film or incorrect loop setter adjustments.

#### B. Adjustments

In the normal operate position with good film the loop setter roller should rest at approximately 7:30 o'clock (Fig. #60), with the flat side of the gear (11) parallel to the main drive belt with approximately 0.2 ~ 0.3mm of clearance. The belt must ride flat with respect to the gear (Fig. #65). If not, the tension gear and arm assembly is not aligned correctly. To correct this condition it may be necessary to reform the tension gear arm. With the belt and gear parallel the loop setter roller is adjusted to the 7:30 position by loosening the arm position screw (10). While holding the gear in place, adjust the arm position and secure the screw. Operate the projector without film. If the loop setter rotates more than once with a small amount of upward pressure, the spring (12) tension is too loose. Remove the spring and slightly stretch or replace it. Re-adjust and test again.

#### C. Loop Setter Timing:

Correct timing is required for proper operation of the loop-setter. Set the projector to selfthread.

Turn on the projector and insert a 2 – 3 meter strip of good film. When threaded, release the threading mechanism. Observe the loop setter should only rotate once. Continued rotation indicates too small a lower loop. Too large a loop will not reset the loop when missing or damaged sprocket holes are present. The size of the lower loop is determined by the relationship between the claw and the #2 sprocket drive.



Fig. #62

To increase the lower loop size, stop the projector, loosen the #2 sprocket cover screw, slightly rotate the sprocket teeth plate counter clockwise (Fig. #63). To decrease the loop, rotate the sprocket teeth plate clockwise (Fig. #64). Tighten the cover screw. Unthread the projector, re-thread and release the threading mechanism. It may require several repeat adjustments to achieve approximately 5mm of clearance between the loop and the loop setter roller (Fig. #62). Correct timing will result in one loop setter cycle when two successive damaged sprocket holes or a bad splice pass through the gate. In some cases continuous cycling of the loop setter may be caused by very poor or damaged film or too strong a take-up tension. Excessive take-up tension may cause the film to skip over the #2 sprocket drive resulting in lower loop loss.



TOO SMALL A LOWER LOOP Fig. #63



TOO LARGE A LOWER LOOP Fig. #64

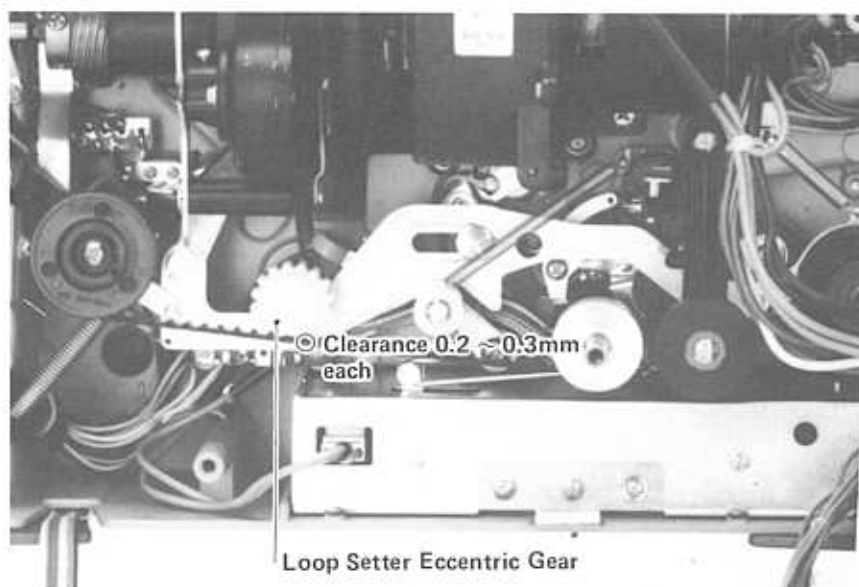

Fig. #65

## 6-4 : SELF-THREADING MECHANISM

### A. Description:

The self-threading mechanism is activated by pushing the #2 film guide (10) into the thread position, locking the interlocking bracket (13) to the release bracket (31).

At the same time the #1 film guide (1) is extended from inside the casting to guide the film into the film gate while forming the upper loop. The film shoe is released and the claw is retracted out of the gate by interlocking bracket (20). Film guide #2 (10) lines up with guide #3 (23) and the pinch roller (29) is released from the sound drum.

The loop setter is locked out by the interlocking arm assy. which exerts a downward pressure against the main drive belt preventing the loop setter gear from activating the loop setter during the threading operation. The lower portions of the lamp house cover provide the guides necessary to complete the threading. To thread, turn the function switch to forward, set the #2 film guide to thread, insert the film into the film channel. When the film exits at the last roller, a light tug releases the threading mechanism. The projector is now ready to operate, the safety arm is released and the loop setter is activated, the film shoe and claw lever is also released. The tension around the sound drum is automatically controlled by the tension of the pinch roller.

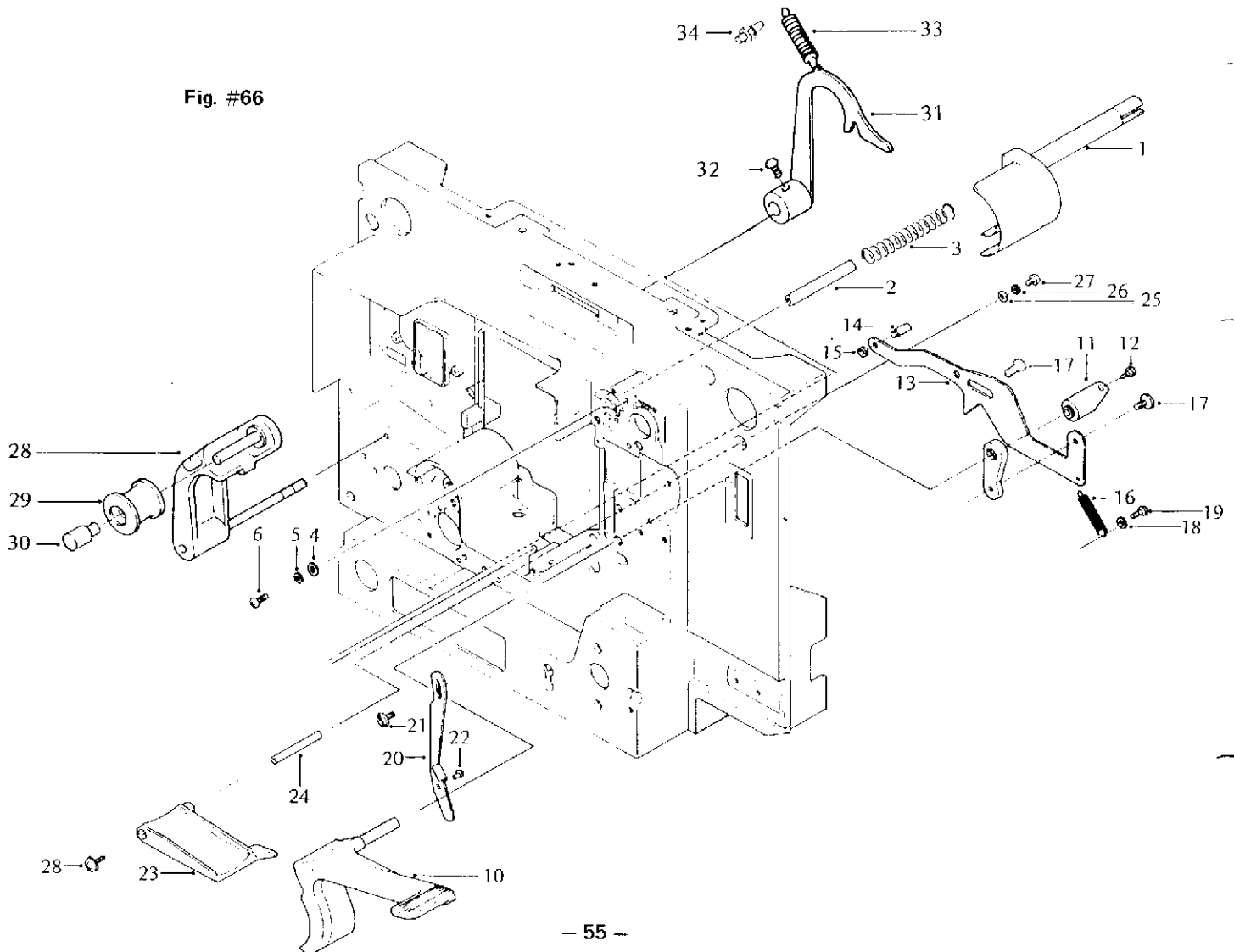

B. Adjustments:

1. #1 Sprocket Shoe Assembly:

The #1 sprocket shoe is spring loaded to keep the film in contact with the sprocket teeth, driving the film into the gate.

Check the shoe clearance using three layers of film in the following manner:

First insert one 5cm (2") strip of film into the film channel, advance the mechanism using the inching knob. When the first strip is fed through the film shoe, insert another strip on the first, continue to advance the inching knob. With two thicknesses of film, the shoe should not begin to open. Next, insert a third strip and advance the inching knob. This time the shoe should slightly open with three layers of film between the sprockets and the shoe.

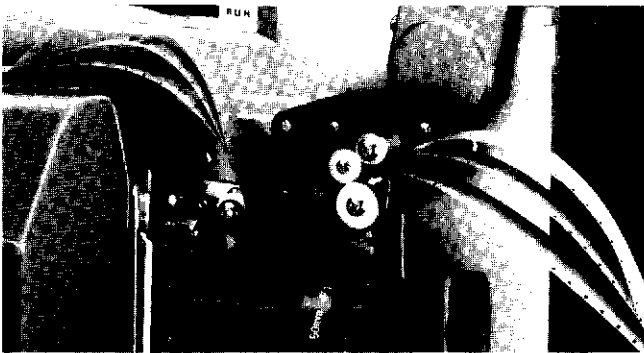

Fig. #67

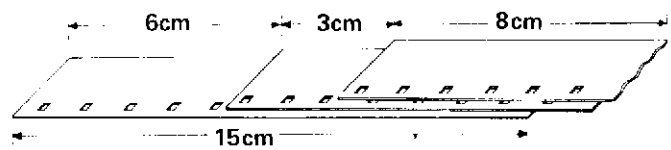

Fig. #68

NOTE : A simple test film may be made by cementing three short strips of film together.

Under normal circumstances, the shoe does not require any adjustments, however, as the film shoe wears, the clearance will become too great, requiring replacement. When a replacement is not available, the small protrusion which determines the clearance may be filed to the correct clearance.

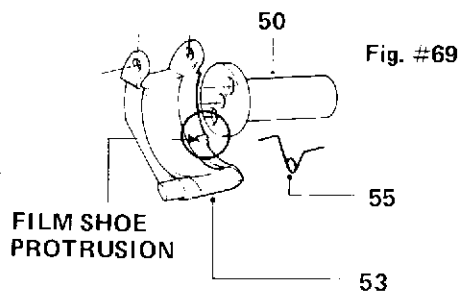

Fig. #69

Too little or no clearance will cause film wear or damage. Care should be taken when removing the shoe not to lose the "V" spring (55).

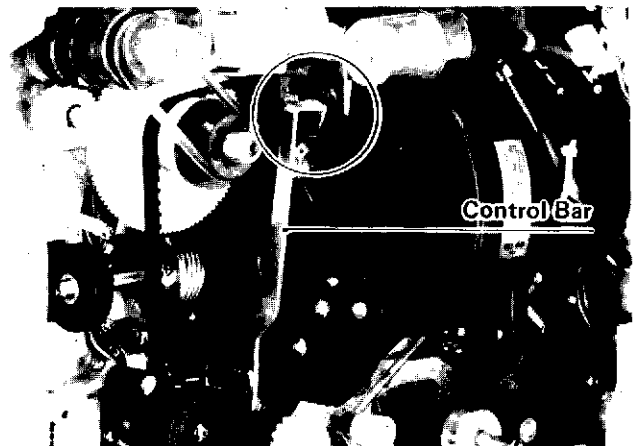

Fig. #70

2. #1 Film Guide:

In the self-thread position, the #1 film guide (1, Fig. #66) is extended from the main casting, guiding the film from the #1 sprocket and shoe into the film gate. After the threading mechanism is released, the guide recedes away from the film path.

The film guide travels approximately 20mm from operate to self-thread. This travel is not critical. There should be enough travel for the guide to retract away from the film in normal operation, and in self-thread extend to the width of the aperture plate. To adjust this travel, a slight twist or bend of the control bar may be required. (See Fig. #70)

NOTE : The position of the cam tank may affect the position of the control bar which activates the #1 film guide. It is important that the control bar aligns with the #1 film guide.

3. Retraction Of The Claw:

When the #2 film guide (10) is set to self-thread, interlocking bracket pushes the claw away from the gate. The claw must be completely retracted, however, if it is pushed too far, the rear of the claw lever will interfere with the shutter blades. A loud click, click sound will be heard.

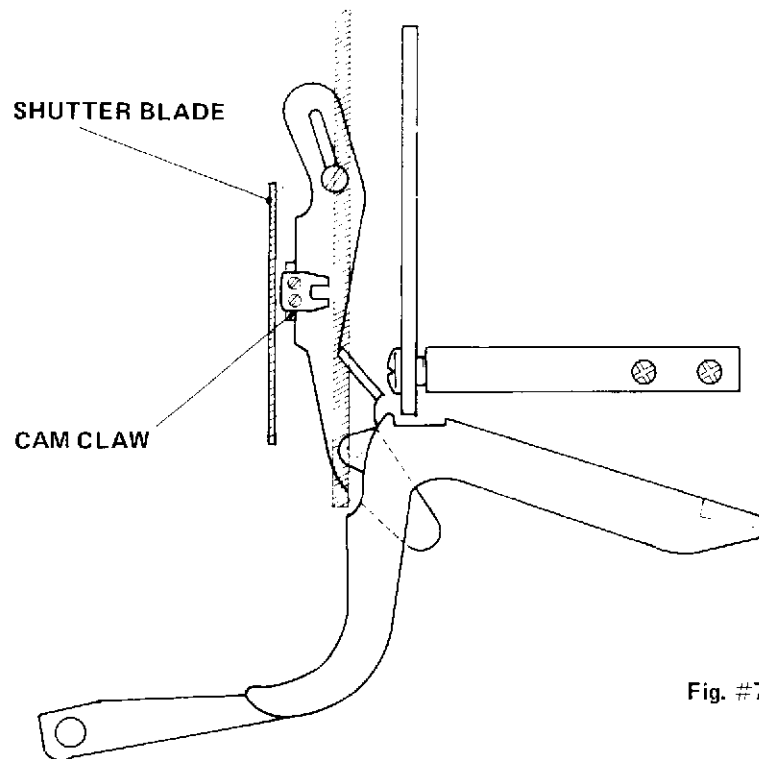

Fig. #71

In instances where the shutter blade has been bent, it may be necessary to re-form the shutter blade.

4. #2 Film Guide:

The #2 film guide acts as the self-threading mechanism setting lever. At the same time it forms the path for the lower loop. When the #2 film guide (10) is set, the cam bracket (11), mounted to the pivot shaft of the #2 film guide, activates the interlocking bracket sub-assy. (13) engaging the release bracket assy.(31) locking the mechanism in self-thread position. To adjust, loosen the set screw (12) on the cam bracket sub-assy. and lock in the release bracket (31) by pushing the interlocking bracket (13) and tighten the set screw making sure the #2 film guide is pushed down completely (See Fig. #72) if the mechanism will not set to self-thread.

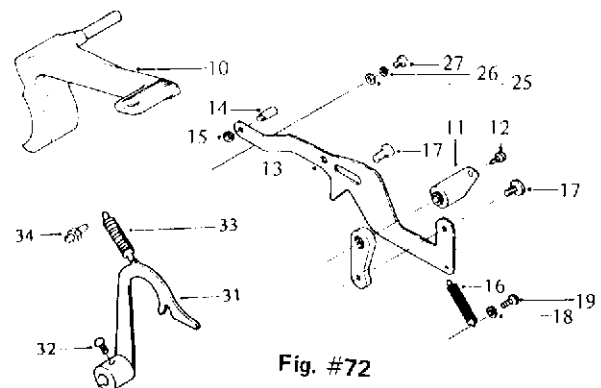

Fig. #72



A small amount of silicone grease on latching pin (14) is required for smooth operation of the latching and release mechanism. It is important that the #2 and #3 film guide line up with a minimum of clearance. Too much clearance will allow the film to go under the #3 guide.

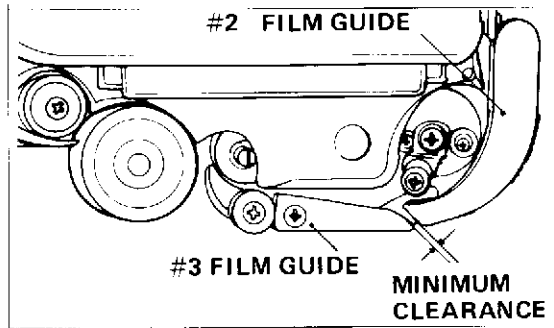

Fig. #73

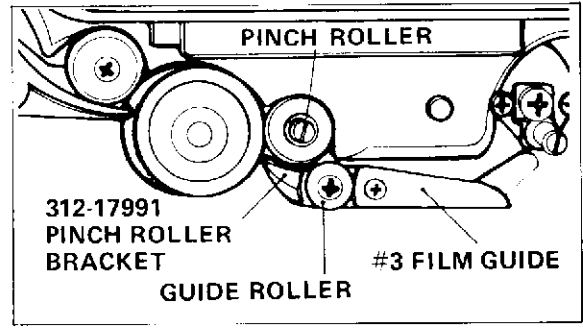

Fig. #74

5. Sound Drum Pinch Roller:  
(Fig. #92, 93)

The sound drum pinch roller is mounted on the #4 film guide (or pinch roller bracket 312-17991) which directs the film up and over the sound drum in the self-thread operation. This is accomplished by the interlocking bracket 315-17971 which depresses pin 315-17371, raising the pinch roller away from the sound drum. When the self-thread mechanism is released, the pinch roller rests firmly against the sound drum.

It is important that the pinch roller be kept clean and that it rotates freely on the shaft. Remove the roller to clean and lubricate.

If the roller does not turn freely, it may restrict the film from advancing over the sound drum during self-threading. A dirty or restricted roller may also contribute to excess wow & flutter. To adjust the tensions of the pinch roller, push the #2 film guide to self-thread position.

- a. Insert two layers of 16mm film between the shoulders of the pinch roller and lamp house casting.
- b. Locate pin 312-17361 so that it touches the bottom edge of the interlocking bracket.
- c. While pressing the pinch roller toward the casting (with film between the roller shoulders and casting), tighten the screw that holds the pin bracket to the roller shaft.

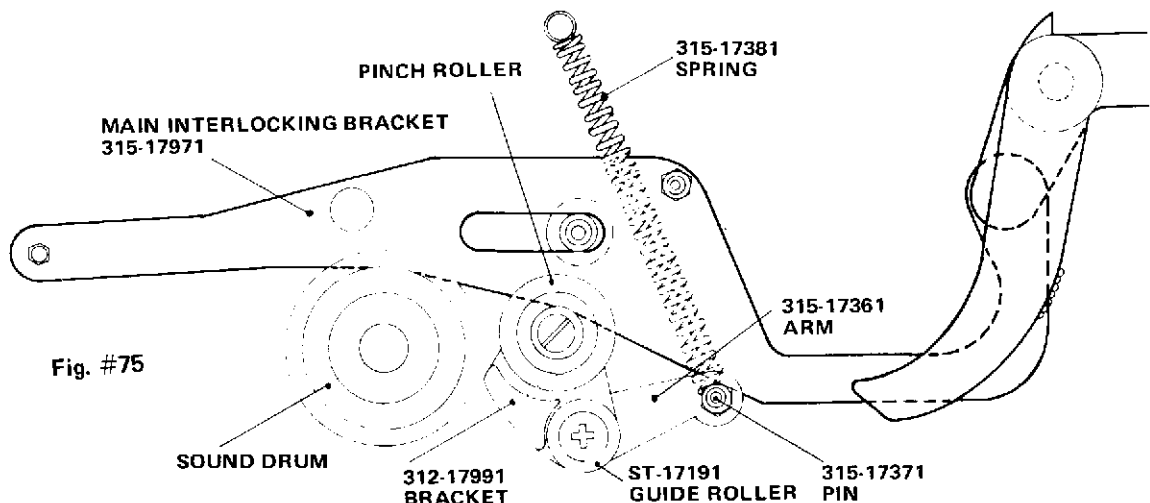

Fig. #75

## 6. Tension Guide And Roller Assembly

The tension guide and roller assembly provides the dampening required between the #2 sprocket drive and the sound drum. When the guide rides midway between its limits, wow and flutter is minimized. During the self-thread operation, the tension guide (26) provides a path for the film to travel from the sound drum to the #2 sprocket drive.

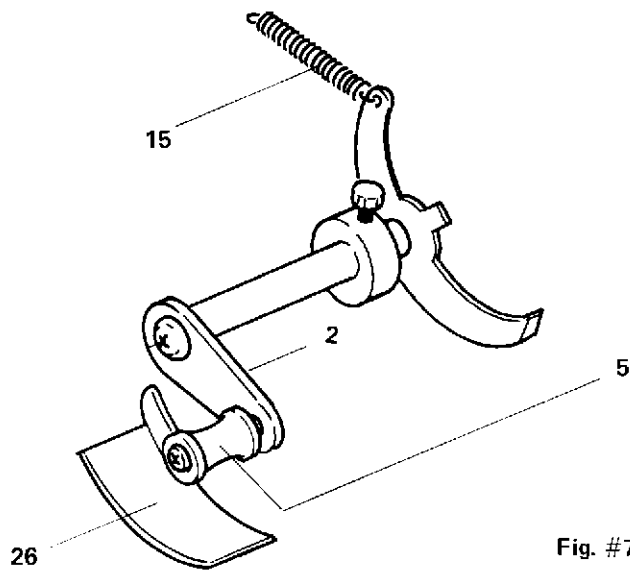

Fig. #76

The tension rollers (5) must be clean and rotate freely on the shafts. The tension arm (2) must pivot freely without binding. A rhythmic movement of the tension arm roller assembly indicates that a roller or the sound drum is binding or out of round. An out-of-round or bent #2 sprocket drive will also cause excessive tension guide movement. All of the above symptoms will result in abnormal wow and flutter. The tension of the arm roller assembly is determined by spring (15) and can be adjusted by replacing the spring or slightly stretching or shortening the spring to achieve minimum wow and flutter. All nylon rollers should be cleaned with alcohol and lubricated sparingly with silicone oil.

## 7. Tension Arm Assembly:

With the self-thread lever to the thread position, the correct clearance with the pin is approximately 0.2mm as shown in the Fig. #77.

To adjust loosen the screw (18), set the thread-lever to the thread position and contact the tip of the interlocking arm (12) on the bracket (13). Fig. #78. Keep clearance of approximately 0.2mm between the tension arm (2) and the pin. Tighten the screw (18).

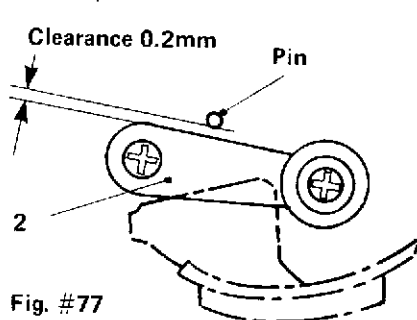

Fig. #77

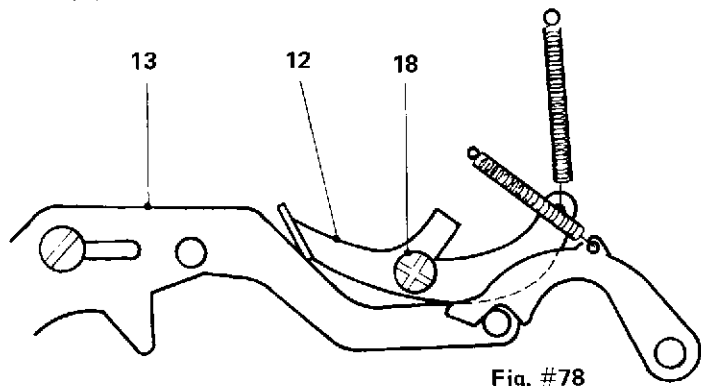

Fig. #78

8. Release Roller Arm Assembly:

With the self-thread lever to the thread position, the release roller arm should provide a clearance of approximately 0.5mm between the release roller (29) and the film guide (7) as shown in the Fig. #79.

To adjust loosen the screw (32), set the self-thread lever to the thread-position. Make sure the pin (14) of the interlocking bracket (13) is completely locked by the interlocking arm (31) as described in the Fig. #80.

The correct clearance of approximately 0.5mm is obtained by adjusting the release roller arm (28). Tighten the screw (32).

Note : Remove the spring (33) and make sure the release roller arm (28) is moving freely and smoothly. No end play in the shaft of the roller arm is allowed.

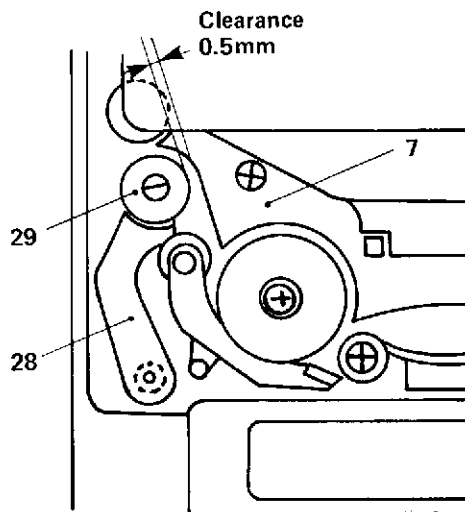

Fig. #79

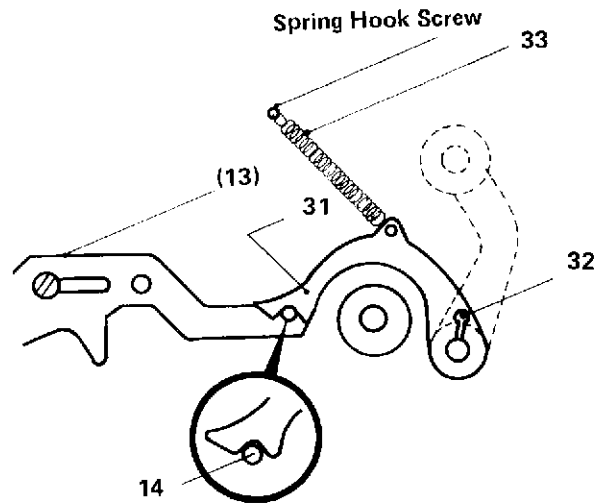

Fig. #80

9. #2 Sprocket And Shoe Assembly:

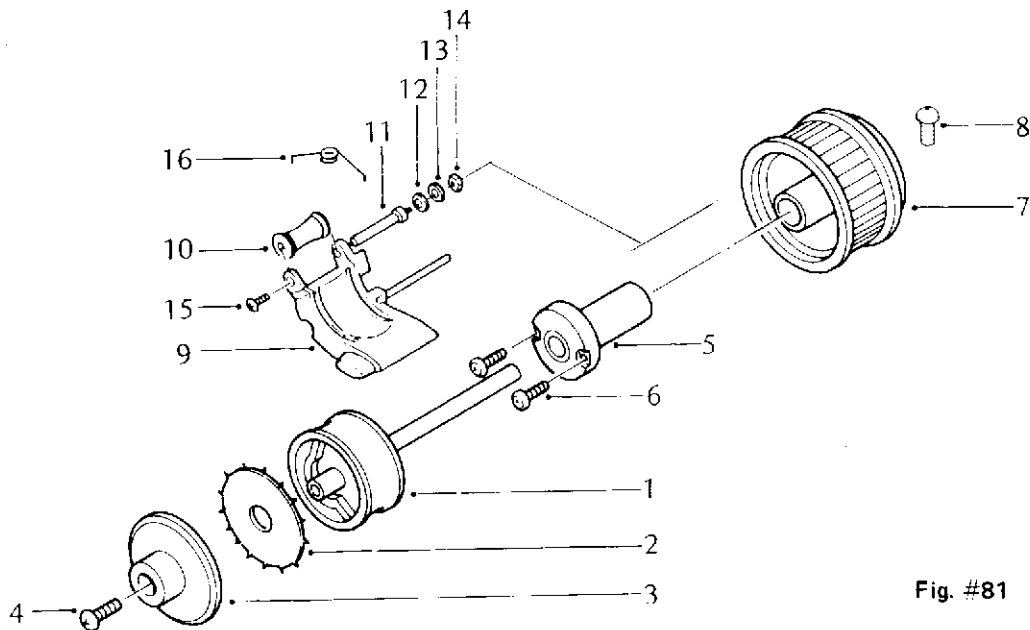

Fig. #81

The drive consists of the sprocket cover (3), the sprocket teeth plate (2), the sprocket drum and shaft (1), the hub and bushing assembly (5), and the drive gear (7). There must be no end play of the sprocket drum shaft in the bushing.

The sprocket plate (2) must be in good condition, with no defective sprocket teeth, otherwise it must be replaced. For correct timing adjustment of the #2 sprocket drive assembly, refer to the loop setter section. (Sec. 6-3)

The #2 sprocket shoe keeps the film in contact with the sprocket teeth. The shoe should always remain closed. The shoe tension is maintained by the "V" spring (16). It is important to note that the #2 sprocket shoe spring is stronger than the #1 sprocket shoe spring. The proper clearance between the shoe (9) and the sprocket drum (1) is very important. To test this clearance, take short piece of film and feed it into the #2 sprocket using the inching knob to advance the projector's mechanism. Add another strip of film on top of the first and advance the projector. With a double thickness of film the film shoe should not begin to open. Add a third layer of film and advance the projector. This time the film shoe should begin to open, indicating that the shoe clearance is correct.

**NOTE :** A simple test film may be made by cementing three short strips of film together. (See Fig. #82)

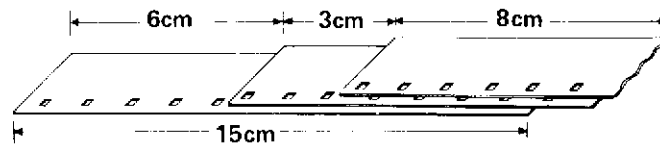

**Fig. #82**

The proper film shoe clearance is determined by a small protrusion molded on the shoe which indexes the shoe against the bushing hub (5). (Fig. #83)

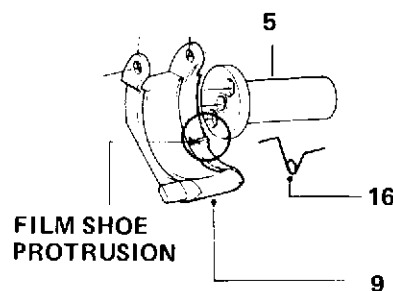

**Fig. #83**

As the shoe wears it may be necessary to replace it to obtain the correct clearance. In some cases the shoe clearance may be reduced by filing the protrusion.

**CAUTION :** Too close a clearance will result in poor threading or possible film damage.

## 6-5 : REWIND SYSTEM

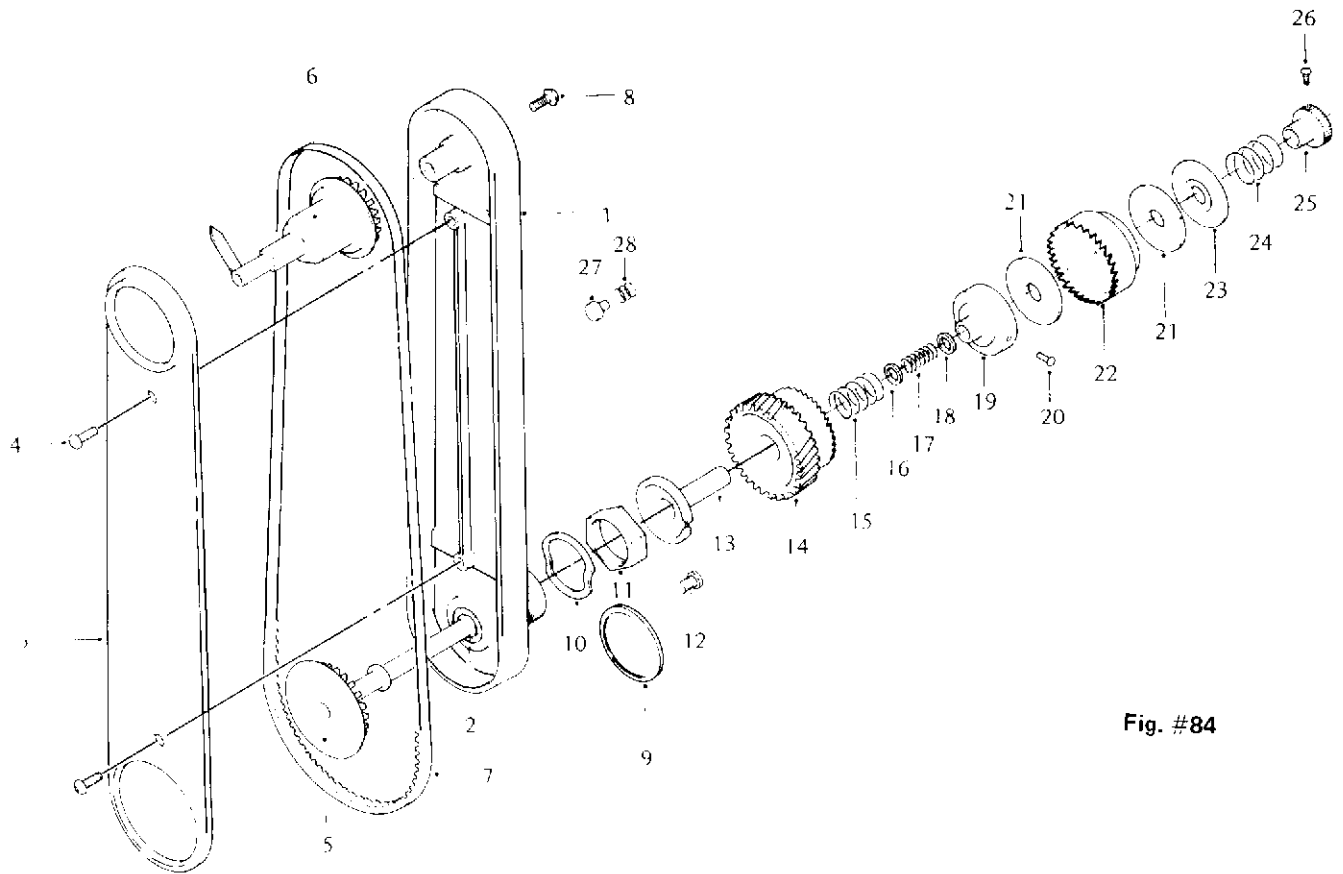

Fig. #84

### A. Description

The rewind is accomplished by connecting the film from the take-up reel to the supply reel. Set the function switch to Rewind/Reverse position to energize the main drive motor and solenoid (21). Fig. #87

The rewind control arm moves the rewind drive gear (14) towards the mating driven gear (22) which in turn drives the set collar (19) via a cork clutch plate which drives the pulley shaft, arm belt and arm spindle assy.

The large drive gear tension spring (15) provides the tension keeping the drive gears A (14) & B (22) from engaging during forward. The smaller back tension spring (17) maintains a small amount of back tension to the supply reel. The rewind spring (24) sets up the rewind clutch tension by supplying pressure to the sleeve plate (23), the cork clutch liners (21) which in turn transmits the rewind drive from drive gear A to B and to the drive pulley shaft, belt and spindle. (Fig. #84).

## B. Adjustments

### 1. Rewind Mechanism

A 0.5mm clearance between the two mating drive gears is critical for correct rewind engagement. This distance is maintained by fiber washers as indicated, adding or subtracting washers as may be necessary to accomplish the desired clearance. Too much clearance will result in improper mating of the gears and will damage the gears. Too close a clearance will cause the gears to contact in forward, resulting in abnormal gear wear and noise. With the correct fiber washers the clutch springs should be compressed with the set collar pushed all the way towards drive gear A and secured with the set screw. (Fig. #85)

### 2. Rewind Spring Adjustment

The knurled nut (25) adjusts the rewind torque. Excessive rewind torque will cause the motor belt to slip when rewinding a large full reel; too little rewind torque will not rewind a large 2000' reel. The correct adjustment must reduce the space between the clutch hub and knurled nut to be less than the thickness of the adjusting spring.

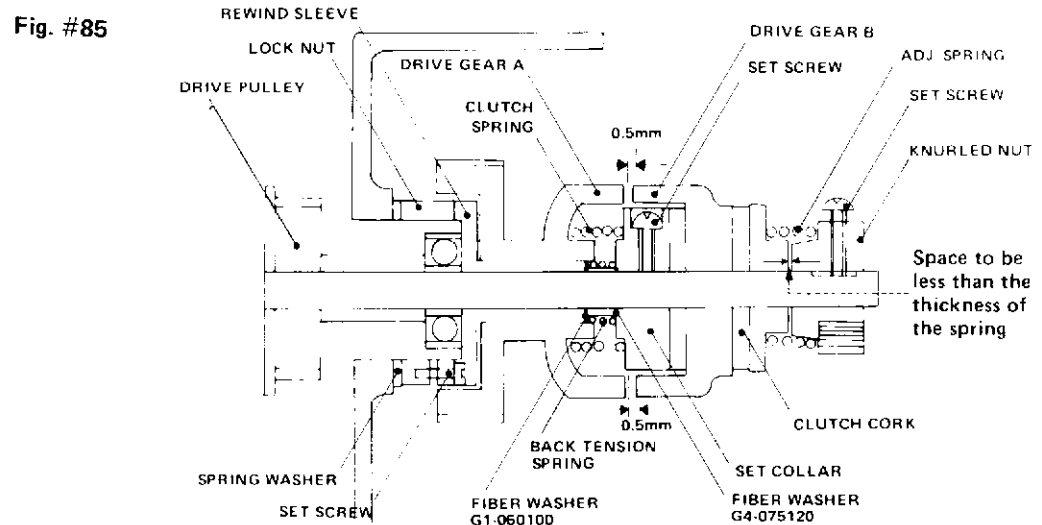

### 3. Rewind Solenoid Adjustment:

When the rewind drive gears A & B, Fig. #85, are completely engaged the solenoid plunger must be fully seated in the bottom of the coil.

To adjust, disconnect the main motor 6P connector to prevent any possible injury from the moving shutter, or gears.

- Loosen the two solenoid mounting screws (XT-3006S) Fig. #87.
- Turn the function switch to reverse/rewind to activate the solenoid. Caution: Do not switch on the lamp with out the motor fan running.
- Manually press the rewind lever (25) Fig. #87, until the drive gear (14) is engaged completely with the driven gear (22).
- With the mounting screws loose move the solenoid assembly back and forth until the plunger is completely seated and the drive gears are fully engaged.
- Tighten the solenoid mounting screws (XT-3006S).
- Switch the function control to stop to be sure the drive gear is released. Manually press the rewind lever (25) several times to be sure that it engages and releases freely.
- With the solenoid adjusted correctly lock the mounting screws with a drop of glyptal.

NOTE : Improper seating of the solenoid plunger will cause the coil to hum and overheat.

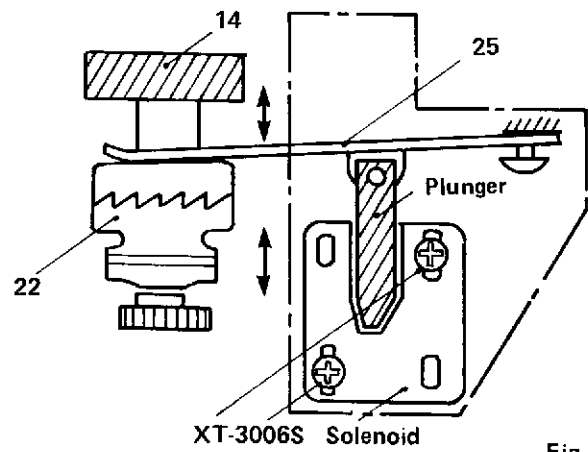
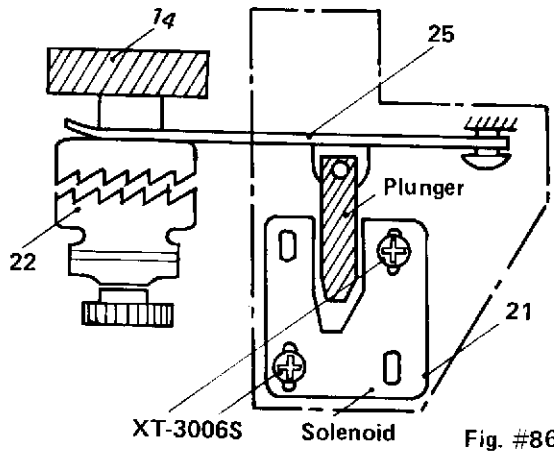

## 6-6 : SOUND DRUM AND FLYWHEEL

### A. Description

The sound drum and flywheel assembly's main function is to stabilize the film, allowing the sound optics or magnetic head to read the sound tracks with a minimum of speed variations. The sound drum, shaft, bearing and flywheel are precision machined and balanced to maintain a consistent linear film speed. Care should be used when disassembling or re-assembling these precision parts.

The sound drum shaft (46) is seated in two precision ball bearings (48) which are sealed and factory lubricated. The ball bearings are lightly press fitted into the sound hub casting (47). The shaft is secured in place by a set collar (53). With the fiber washer in place, with no end play in the sound drum shaft, it must rotate freely and not bind. Any binding or imperfections in the ball bearing will result in excessive wow & flutter. In the forward direction, the sound drum shaft (46) is driven by the tension of the film. The flywheel is free to slip on the sound drum shaft during the initial start up of the projector to prevent any possible film damage.

### B. Adjustments

The ball bearings are life time lubricated and lightly presses into the hub (47). The amount of shaft (46) end play should not exceed 0.2mm and is determined by the set collar's (53) position. Care should be taken not to bend the shaft or lubricate the bearings. (Bearings are factory lubricated and should be replaced if defective). Defective or incorrect lubrication of the bearings will result in excessive wow and flutter.

The plate spring (57) tension may be adjusted for minimum wow and flutter with the screw secured.

Whenever removing the spring and flywheel is necessary, care should be taken to avoid changing the plate spring's tension.

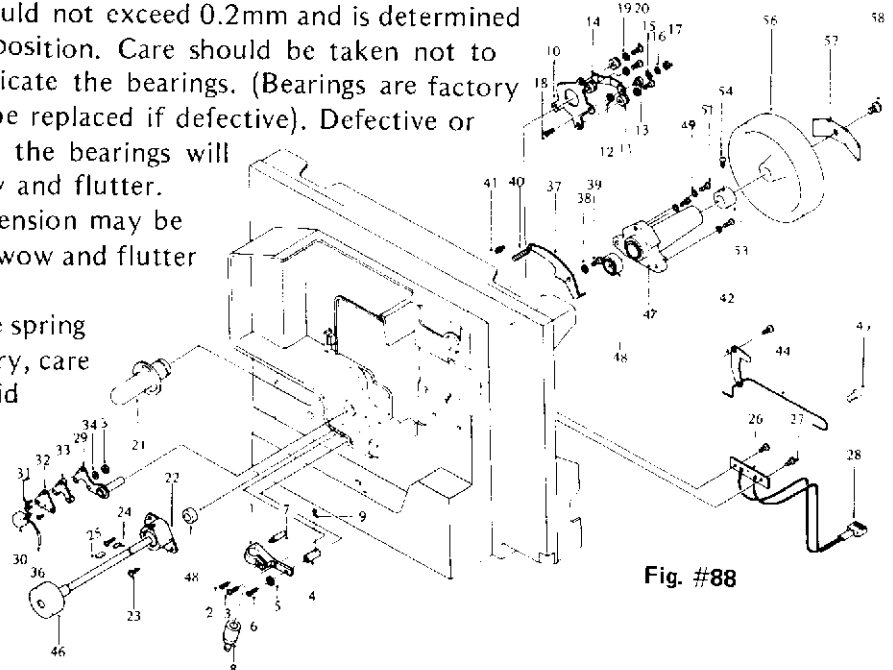

## 6-7 : REVERSE PROJECTION

### A. Description

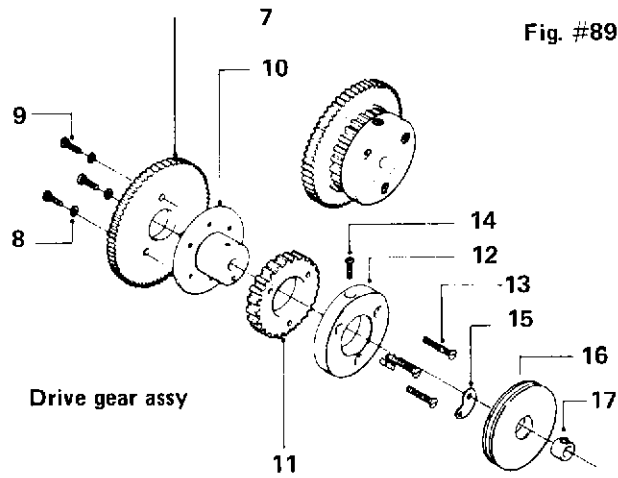
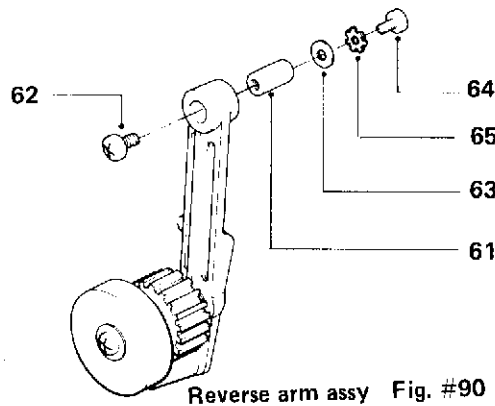

Fig. #89

In reverse the motor rotates in a counter-clockwise direction engaging the reverse take-up clutch cam (19) which in turn drives the clutch cover pulley (18), driving the reverse belt. At the same time the main drive belt drives the reverse rubber roller (Fig. #90 & Fig. #91) against the set collar behind the flywheel, thereby driving the set collar or the sound drum in the counter clockwise direction.



Reverse arm assy Fig. #90

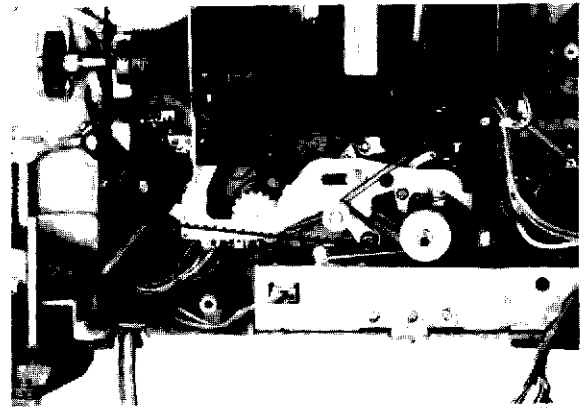

Fig. #91

Driving the flywheel is necessary to maintain the lower loop when operating the projector in reverse. In normal forward projection the main drive belt carries the reverse arm assembly away from the set collar where it can rotate freely. The rubber roller must not be in contact with the set collar in the forward mode.

### B. Adjustments:

The reverse take-up clutch requires no lubrication except the bushing of the clutch cover pulley (16). (See lubrication chart). When re-assembling the reverse take-up clutch mechanism, it is important that the clutch cam (15) be positioned correctly. A space of approximately 0.2mm is required between the drive gear assembly and the pulley (16). This is determined by the position of the set collar (17).

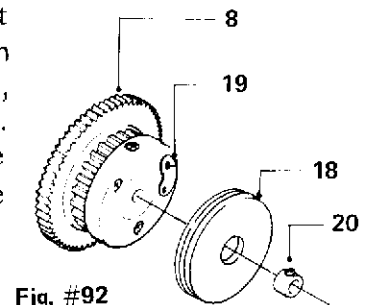

Fig. #92



The reverse rubber roller requires no adjustments as long as the main drive belt is in contact with the roller's drive gear. The reverse the sound drum during reverse. This action can be observed by operating the mechanism manually via the inching knob and with the flywheel removed. The rubber roller should be clean and free from any grease or oil. A dry or glazed roller should be replaced.

# 315-7: SOUND PICK-UP SYSTEM

## 7-1 : OPTICAL SOUND FOCUSING PROCEDURE

### A. Description

Models ENT/SNT-0, 1 are optical sound playback only, models ENT/SNT-2 are both optical and magnetic playback. The optical pick-up system resembles a small projector within a projector, consisting of a light source, a lens, an image, and a screen or target.

The light from the exciter lamp is focused through the sound track imaged onto the (target) solar cell where varied light intensity is converted into a minute electrical voltage change which is amplified and converted into acoustical variation or sound directly related to the photographic variations recorded on the film. (Fig. #93)

### B. Sound Focus Alignment Procedure

#### 1. Tools and Equipment Required

- a. Screw driver set (Iso)
- b. Sound lens adjustment tool (Tool No. 320-02T.Fig. #95)
- c. SMPTE sound focus test film 7000Hz
- d. SMPTE buzz track test film
- e. AC VTVM (audio range) and or
- f. Oscilloscope
- g. 8 ohm 30 watt dummy load resistor
- h. External speaker (front cover)

#### 2. Set-up Procedure

- a. Remove the lamp house cover assy. complete, light shield and lamp.
- b. Remove the exciter lamp.
- c. Insert the Tool No. 320-02T on the larger barrel of sound lens and tighten a set screw on the tool. (Fig. #96 )
- d. Loosen a sound lens lock screw, and mount the sound lens clamped to the tool to the lens holder assy.
- e. Re-install the exciter lamp.

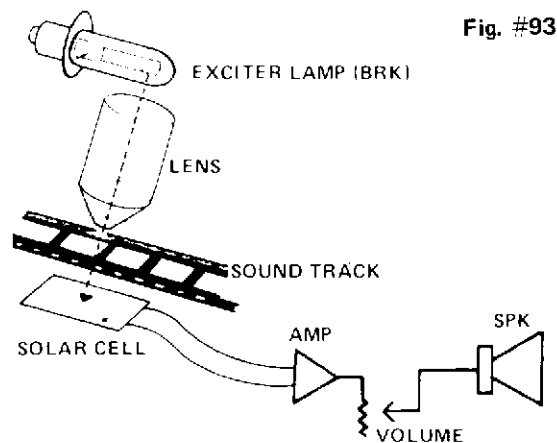

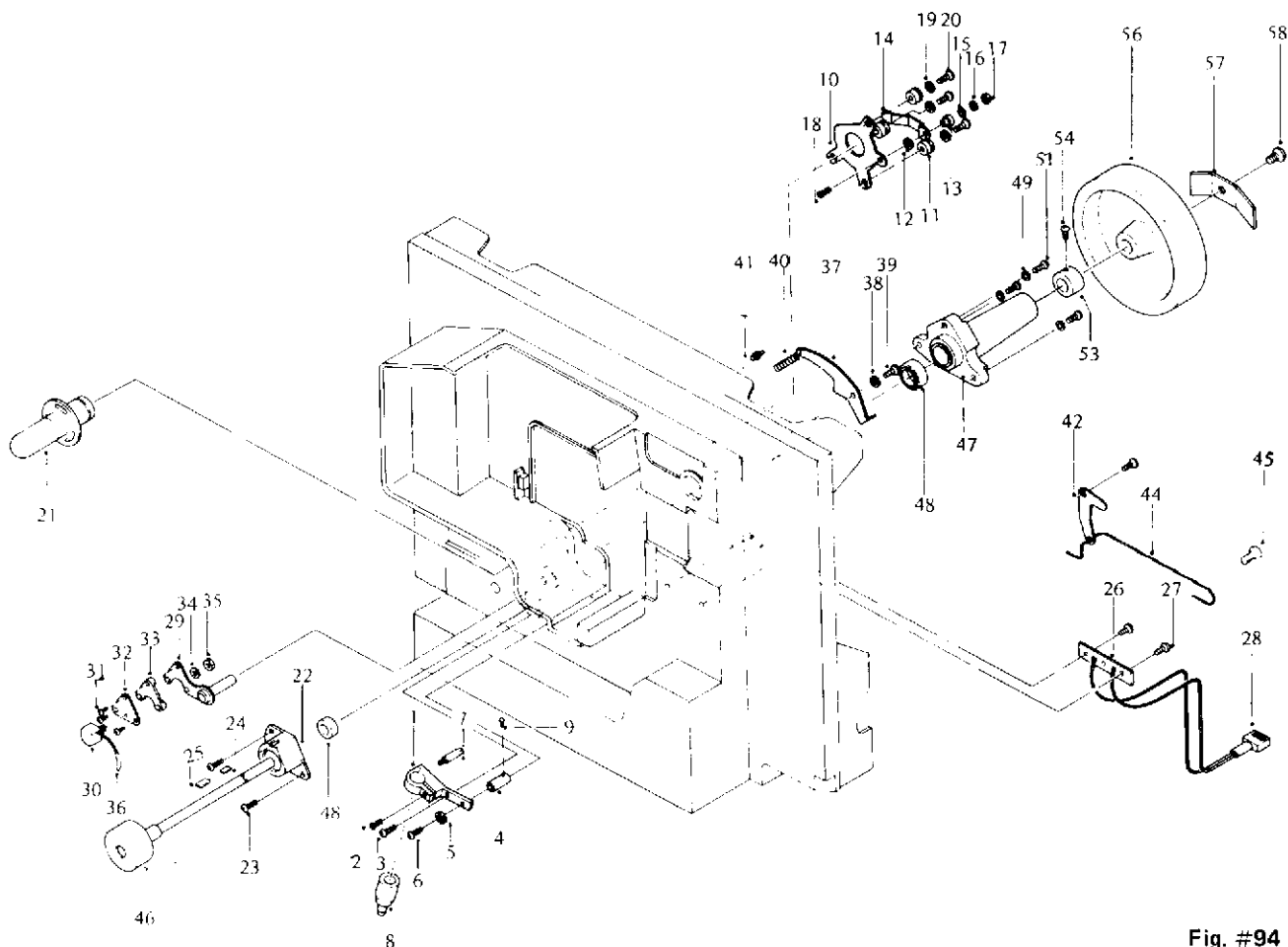
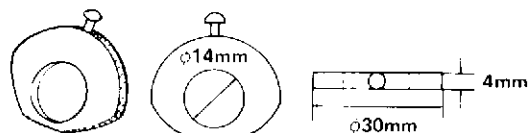

Fig. #94



SOUND LENS ADJUSTMENT TOOL  
320-02T

Fig. #95

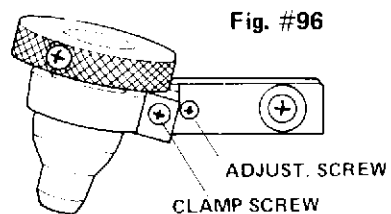

Fig. #96

ADJUST. SCREW  
CLAMP SCREW

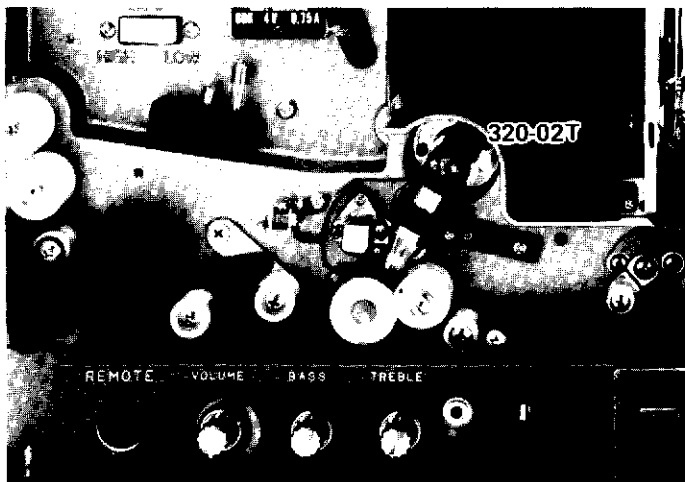
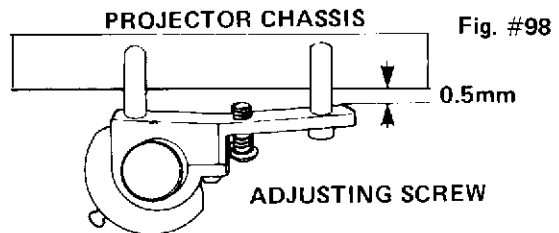

Fig. #97



PROJECTOR CHASSIS Fig. #98

ADJUSTING SCREW

Note : Keep 0.5mm distance from the casting. (Fig. #98)

Note : The top of the adjusting screw should not touch the casting. (Fig. #98)

### 3. Adjustment Procedure

- a. Connect the dummy load resistor to the speaker output jack.
- b. Load the 7000Hz SMPTE test film loop with the emulsion side towards the film sprocket.
- c. Connect either an AC VTVM (20 volt range) or an Oscilloscope across the dummy load resistor. ( Fig. #99 )

Note : When using instruments with a grounded shield input, avoid a ground loop condition by not connecting the shield at both ends.

- d. Turn the volume and tone controls to the maximum (clockwise) position.
- e. Loosen the sound focus lens clamp screw slightly to allow a rotation of the lens.
- f. Turn on the projector and observe the AC VTVM or the Oscilloscope.
  - (1) With the AC VTVM connected, observe the meter while slowly moving the lens up or down and slightly rotating until the maximum voltage reading is achieved. Clamp the sound lens and this completes the sound focusing alignment.
  - (2) With the Oscilloscope connected across the dummy load resistor a more precise alignment can be achieved. Observe the 7000Hz sine wave at both full volume and a lower volume at the same time adjusting the rotation and up or down position of the sound lens, for maximum P-P voltage of the sine wave. A clean undistorted sine wave should be observed as shown in Fig.#102 corresponding to the volume and tone control positions as indicated.
- g. This completes the Sound Focus adjustment. Lock the sound lens clamp screw and test with a good sound track film.

### 4. Buzz Track Adjustment Procedures

- a. Connect an extension speaker to the speaker jack.
- b. Thread an SMPTE buzz track test film loop with the emulsion side towards the film shoe.
- c. Turn the function control switch to forward.
- d. Turn the amplifier volume and tone controls to maximum (clockwise) and listen for a clear 1000Hz tone.
- e. Adjust the buzz track alignment screw clockwise until the 1000Hz tone is inaudible and a 300Hz tone becomes audible.
- f. Turn the set screw counter-clockwise until neither the 300Hz or the 1000Hz tone is audible, indicating correct buzz track alignment.
- g. Re-check the 7000Hz sound focus alignment.
- h. Remove the exciter lamp. Remove the lens adjustment tool. Re-install the exciter lamp and wipe off any fingerprints.

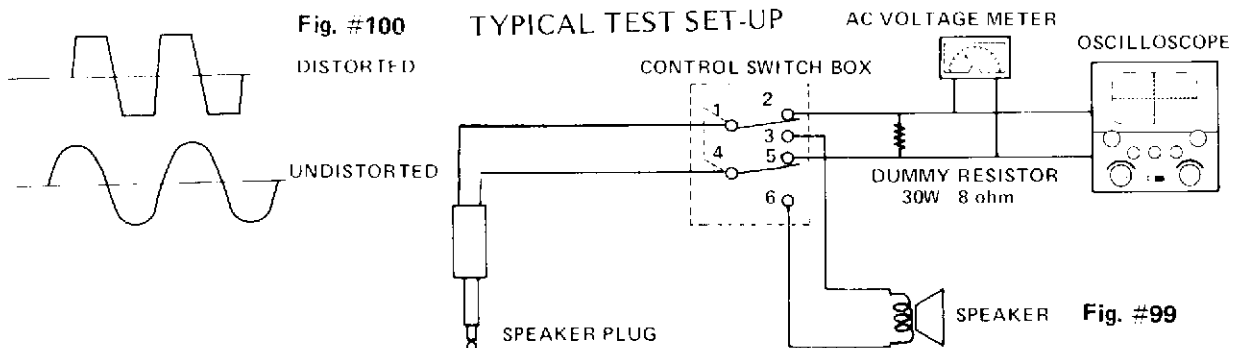

## 7-2 : MAGNETIC SOUND PLAYBACK SYSTEM

### A. Description

Models ENT/SNT-2 in addition to the standard optical sound reproduction are equipped with optional magnetic track (100 mil) playback only. The opt/mag slide switch on the amplifier effects this conversion by switching the input to the amplifier while at the same time moving the magnetic playback head into position against the film's magnetic sound track.

### B. Magnetic Alignment Procedure

#### 1. Tools and Equipment Required

- a. Screw driver set (ISO)
- b. Magnetic Azimuth 7000Hz alignment SMPTE test film loop.
- c. Pliers
- d. AC VTVM (Audio Range) and or
- e. Oscilloscope
- f. 8 ohm 30 watt dummy load resistor
- g. External speaker (front cover)

#### 2. Set-Up Procedure

- a. Remove lamp house cover assy. complete.
- b. Thread the magnetic test loop (oxide side toward the head)
- c. Turn on the projector.
- d. Slide the mag/opt switch to mag.
- e. Connect the output of the amplifier to the dummy load resistor.
- f. Connect the AC VTVM and or the Oscilloscope across the dummy load.
- g. Check that the magnetic head contacts the film.
- h. Turn the volume and tone controls to the maximum (clockwise) position.
- i. Coarse head adjustment; adjust the three screws adjustment screws for the correct position as shown in (Fig. #101). The head should also contact the film parallel as illustrated in (Fig. #102).

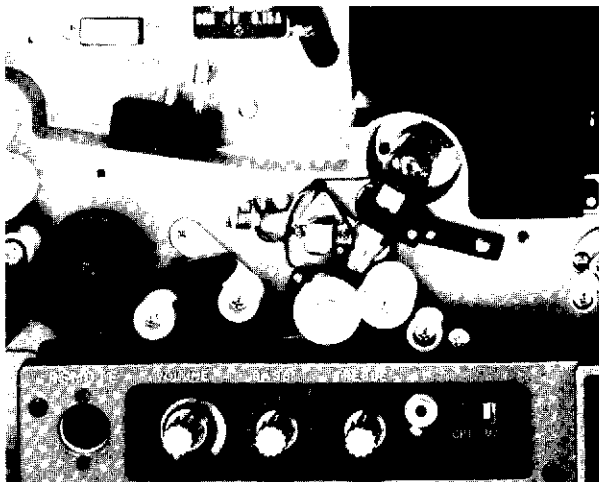

Fig. #101

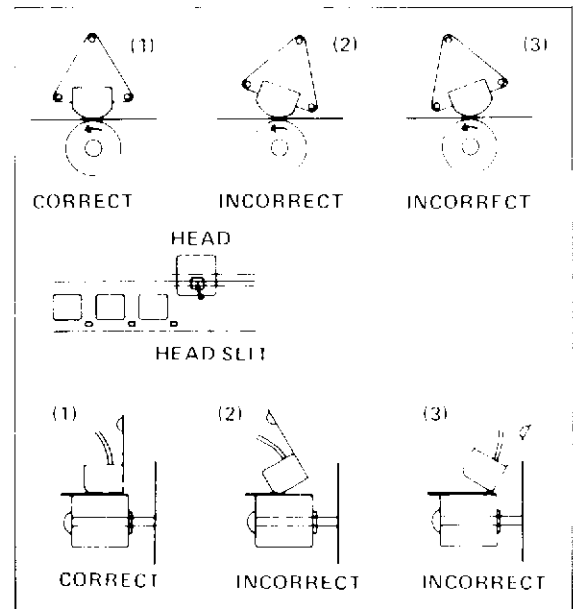

Fig. #102

- j. To precisely adjust the head azimuth using the AC VTVM or Oscilloscope:
  - (1) With the AC VTVM connected across the load resistor, observe the meter while making small adjustments to the three alignment screws in turn until the maximum voltage reading is achieved. This completes the azimuth alignment.
  - (2) With the Oscilloscope connected across the load resistor, observe the 7000Hz sine wave at full and low volume. Adjust the three head alignment screws until a maximum P-P sine wave voltage is observed. When a clean undistorted sine wave at maximum voltage is achieved the alignment is completed.
- k. This completes the Azimuth alignments.
- l. Humbucking coil adjustment is accomplished by carefully bending the coil for minimum hum.

C. Magnetic Head Lift

In the reverse or rewind function the magnetic head lifts up to prevent excess wear from contact with the rotating sound drum. (See Fig.#103). Also at the same time the sound is muted. There is no sound in reverse.

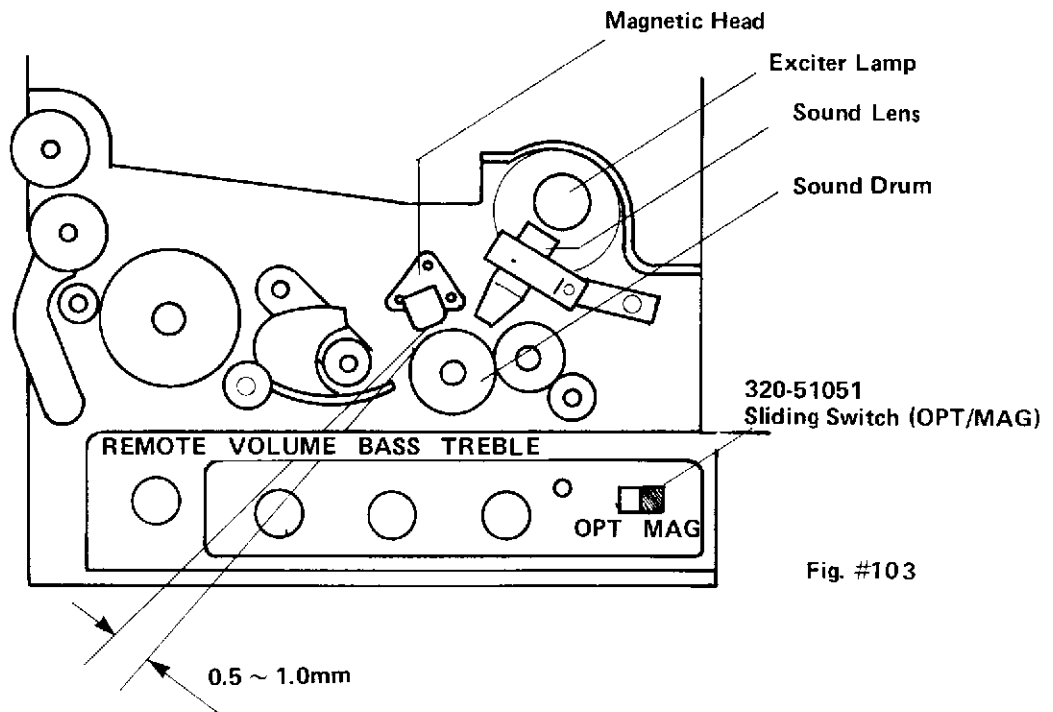

Fig. #103

Reverse or Rewind operation  
at the MAG position "on"

# 315-8: LAMP CIRCUIT

## 8-1 : LAMP CIRCUIT

### A. Description

The SNT/ENT projector is designed with a 24V AC Quartz Halogen Lamp ELC 250 watt. A 200 watt EJL Lamp may also be used with some reduction in light output. A high/low switch located in the lamp house allows the selection of either the normal 24V or the 22V secondary from the transformer.

### B. Replacement and Alignment

1. Disconnect the AC power cord.
2. Unscrew the lock screw and open the lamp house cover.
3. Remove the black heat shield cover.

CAUTION : The shield cover may be hot.

4. Push the lamp ejection lever to the left and the lamp will come out.
5. When replacing a lamp, be sure that it snaps into the lamp socket properly and that the heat shield and lamp house cover are re-installed properly.
6. For the maximum, even illumination, it may be necessary to adjust the lamp position to allow for slight variations in lamps. Turn the knurled nut for horizontal adjustment.

Note : In the event of the lamp socket replacement, and the knurled nut has been removed from the pin, make sure of the correct direction of the knurled nut when re-mounting to the pin. (Fig. #104)

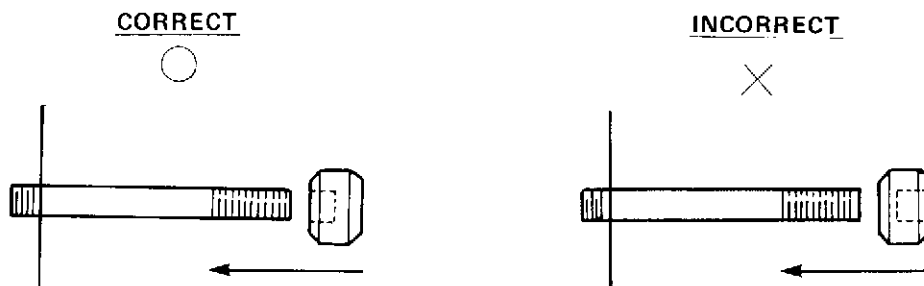

Fig. #104

# 315-9: ELECTRICAL SYSTEM

## 9-1 : ELECTRICAL SYSTEM

### Function Rotary Switch (SNT-Series)

| Micro Sw. # | Type of Sw. & Part No. | Function        |
|-------------|------------------------|-----------------|
| 1           | V-15-1A3M 312-60051    | Motor Forward   |
| 2           | " "                    | Motor Rewind    |
| 3           | " "                    | Motor Rewind    |
| 4           | " "                    | Lamp            |
| 5           | " "                    | Rewind Solenoid |

| Wire # & Color | Type of Wire | Connected to:                      |
|----------------|--------------|------------------------------------|
| Brown #1       | AWG #22      | Motor 6P Connector (F) No. 1       |
| Brown #2       | "            | Transformer 9P Connector (F) No. 1 |
| Brown #3       | "            | Fuse Holder 2A                     |
| White #7       | AWG #18      | Transformer 3P Connector (M) No. 3 |
| White #8       | "            | Lamp Socket                        |
| Yellow #4      | AWG #22      | Motor 6P Connector (F) No. 2       |
| Black #5       | "            | " (F) No. 5                        |
| Blue #6        | "            | " (F) No. 4                        |
| Yellow #9      | "            | Film Sensor Terminal               |

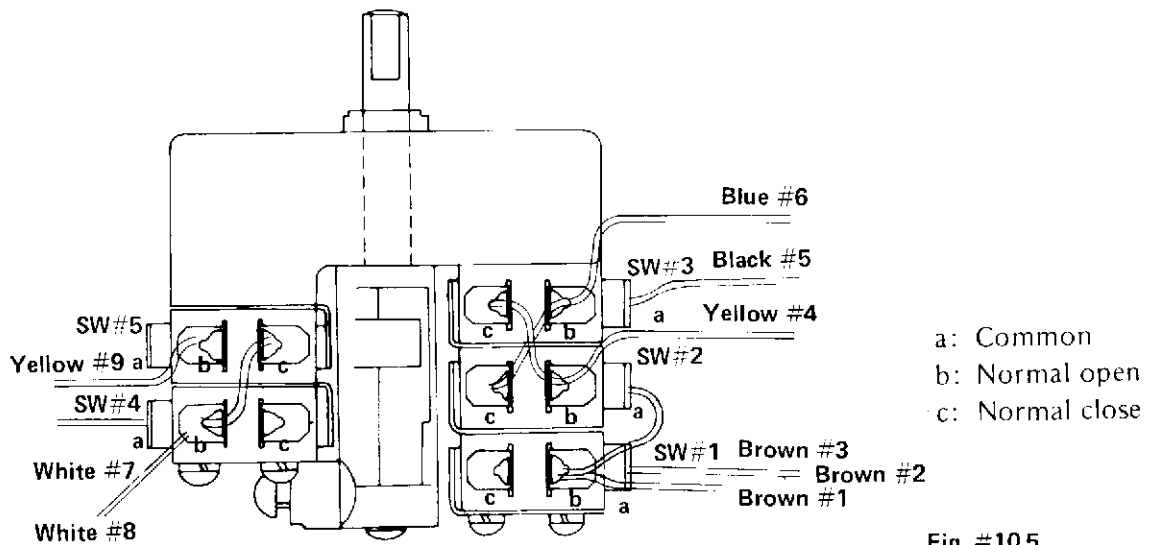

Fig. #105





SNT series



9-2 : ENT ELECTRONIC CONTROL SYSTEM

A. Description:

ENT-Series employs an electronic touch button digital logic control system, with built in remote control circuit. For remote control operation, a hand held remote unit or a custom interface to other electronic control equipment may be made for the following functions. A single P.C. Board (315-61501) contains the control circuits for all the functions.

- stop 
- forward 
- lamp 
- reverse 
- rewind 

All mechanical operations are the same as described for the SNT-Series. To service the P.C. Board, remove the three mounting screws as designated in fig. #107 .

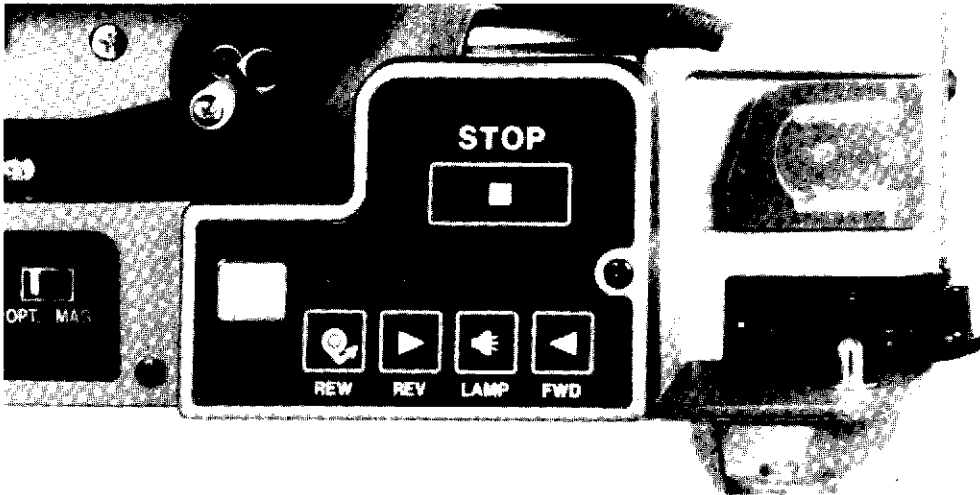

Fig. #106

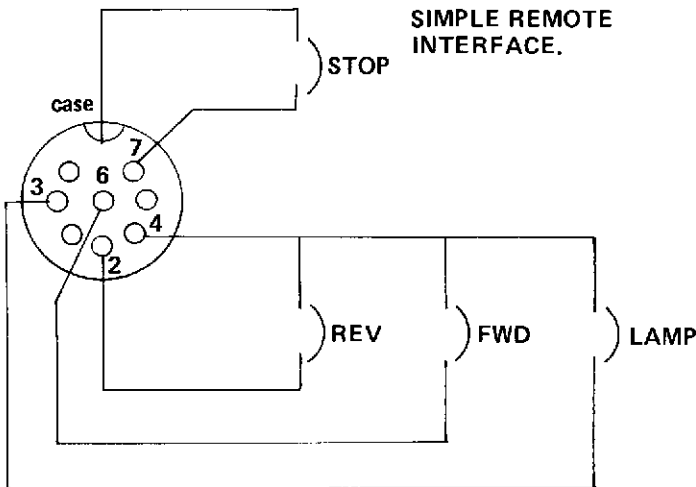

Fig. #107

**B. TROUBLE SHOOTING CHART:**

| SYMPTOM   | PROBABLE CAUSE  | REMEDY  |
|---|---|---|
| 1. No switches activate at all, pilot LED not on  | 1. Power cord not plugged in.<br>2. Fuse blown<br>3. Improper connection with control P.C. Board<br>4. Incorrect AC voltage between #1 & #2 terminal of connector H1<br>5. Incorrect RG 2 output DC voltage | 1. Check<br>2. Check & replace<br>3. Connect correctly<br>4. Check & adjust for voltage approximately AC 14V<br>5. Check & adjust for DC 8V or replace P.C. Board   |
| 2. No switches activate at all, pilot LED on  | 1. Defective IC2 (Incorrect #9 pin out-put)<br>2. Defective IC2 (Incorrect #6 pin out-put)  | 1. Replace IC2<br>2. Check for out-put low level.<br>* Check it #6 pin of IC2 is still low level when disconnected connectors H2 & H3.<br>Replace P.C. Board when it is low level, and check around film guard switch or stop switch when it is high level. |
| 3. Rewind switch on, but no rewind (other switches are good)                                  | 1. Incorrect adjustment on film sensor switch   | 1. Adjust or replace  |
| 4. Lamp switch on, no lamp LED on (other switches are good)                                   | 1. Incorrect adjustment on self-thread control lever switch   | 1. Adjust or replace  |
| 5. Too short (long) time until motor stops after the film exits at the take-up tension roller | 1. Defective VR on control P.C. Board   | 1. Replace with bigger (smaller) VR   |
| 6. Too short (long) time until motor stops at the end of the film                             | 1. Defective R23 on control P.C. Board  | 1. Replace with bigger (smaller) resistor   |
| 7. Poor rewind  | 1. No power on the rewind solenoid<br>2. Faulty rewind relay  | 1. Check & adjust<br>2. Check D2, connector H1 & wiring or replace P.C. Board   |

When two switches (SW-1 & SW-2) are pressed simultaneously;

| SW-1    | SW-2                                  | Function mode selected            |
|---------|---------------------------------------|-----------------------------------|
| STOP SW | FWD SW<br>LAMP SW<br>REV SW<br>REW SW | STOP<br>STOP<br>STOP<br>STOP      |
| FWD SW  | LAMP SW<br>REV SW<br>REW SW           | FORWARD & LAMP ON<br>STOP<br>STOP |
| REV SW  | LAMP SW<br>REW SW                     | REVERSE & LAMP ON<br>STOP         |
| REW SW  | LAMP SW                               | REWIND                            |

C. Timing of each relay for switch mode:

- Drive motor ON-OFF signal (IC5-10) . . . . . A
- Drive motor FWD-REV signal (IC5-8) . . . . . B
- Rewind solenoid ON-OFF signal (IC2-15) . . . . . C

1. STOP MODE:

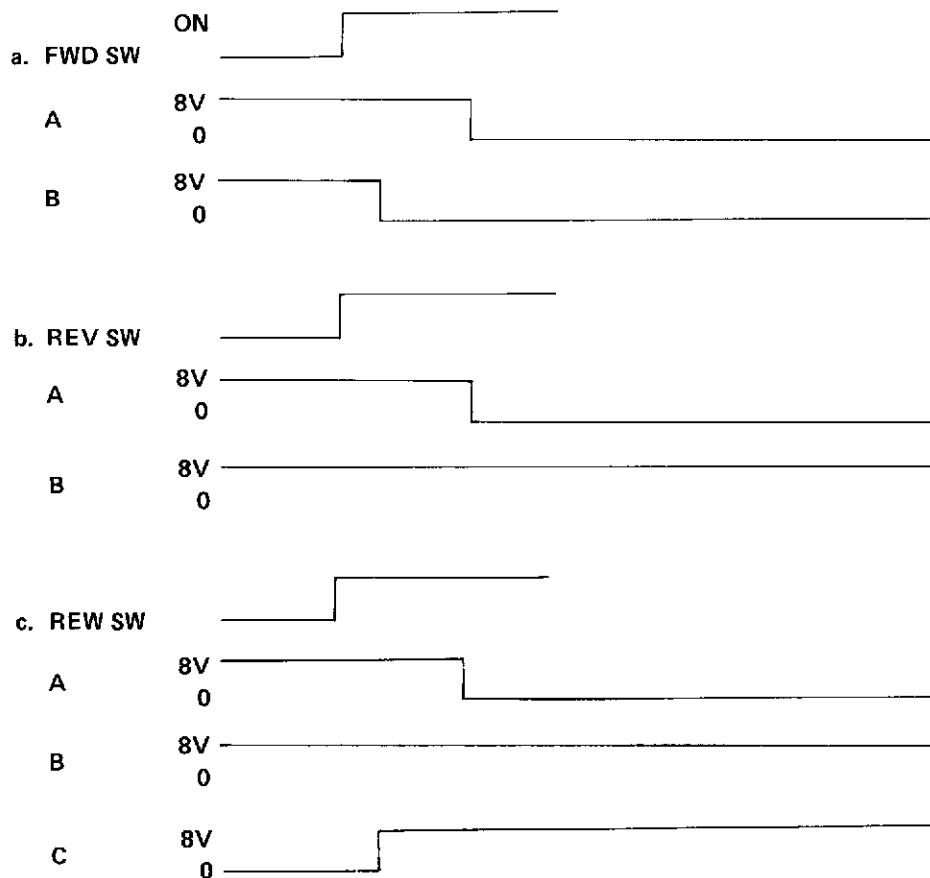

## 2. FORWARD MODE:

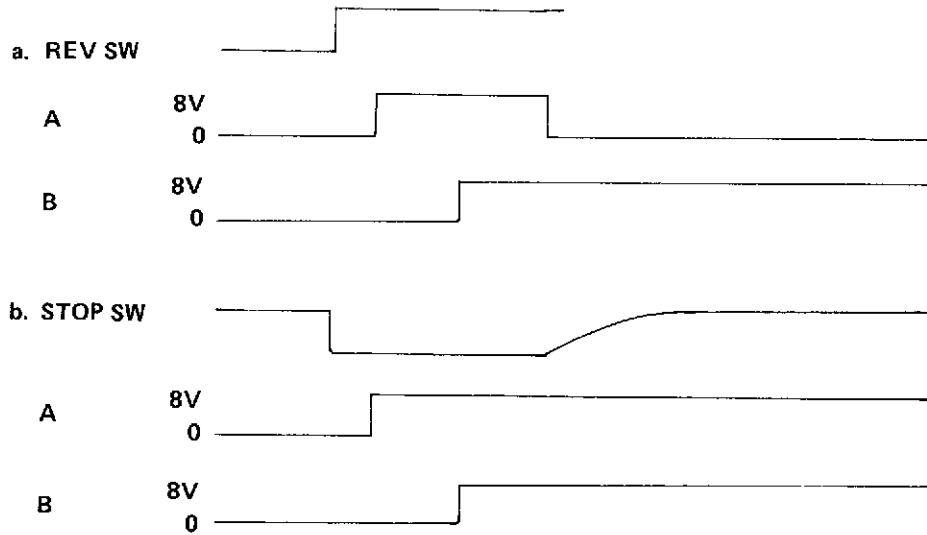

## 3. REVERSE MODE:

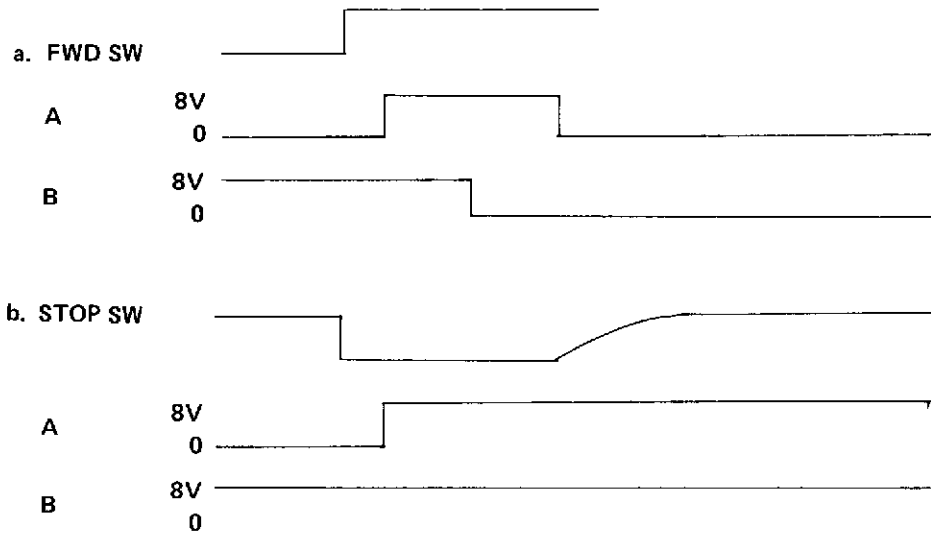

4. REWIND MODE:

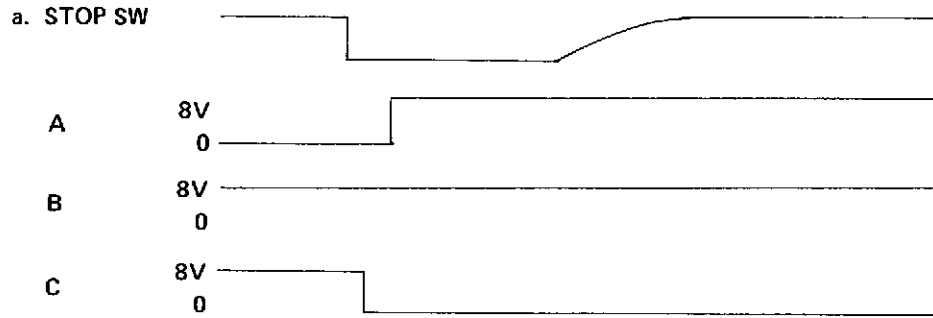

Lamp Relay:

Lamp relay does not activate unless the drive motor ON-OFF relay 'ON'. (see fig. #100)

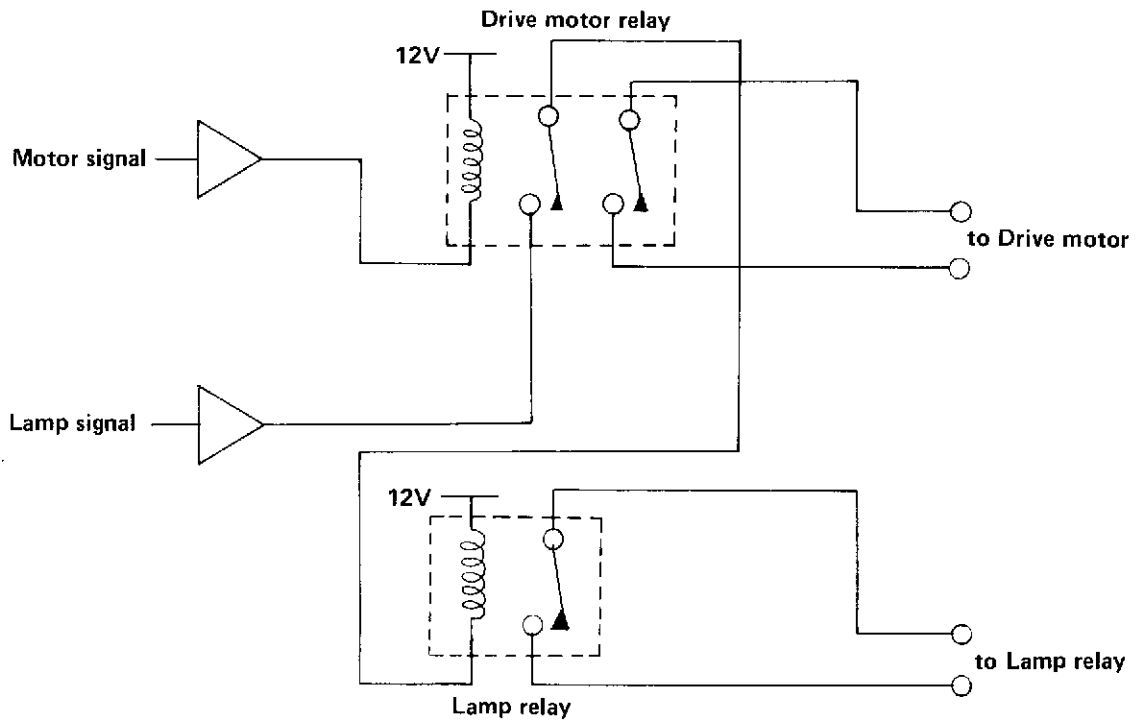
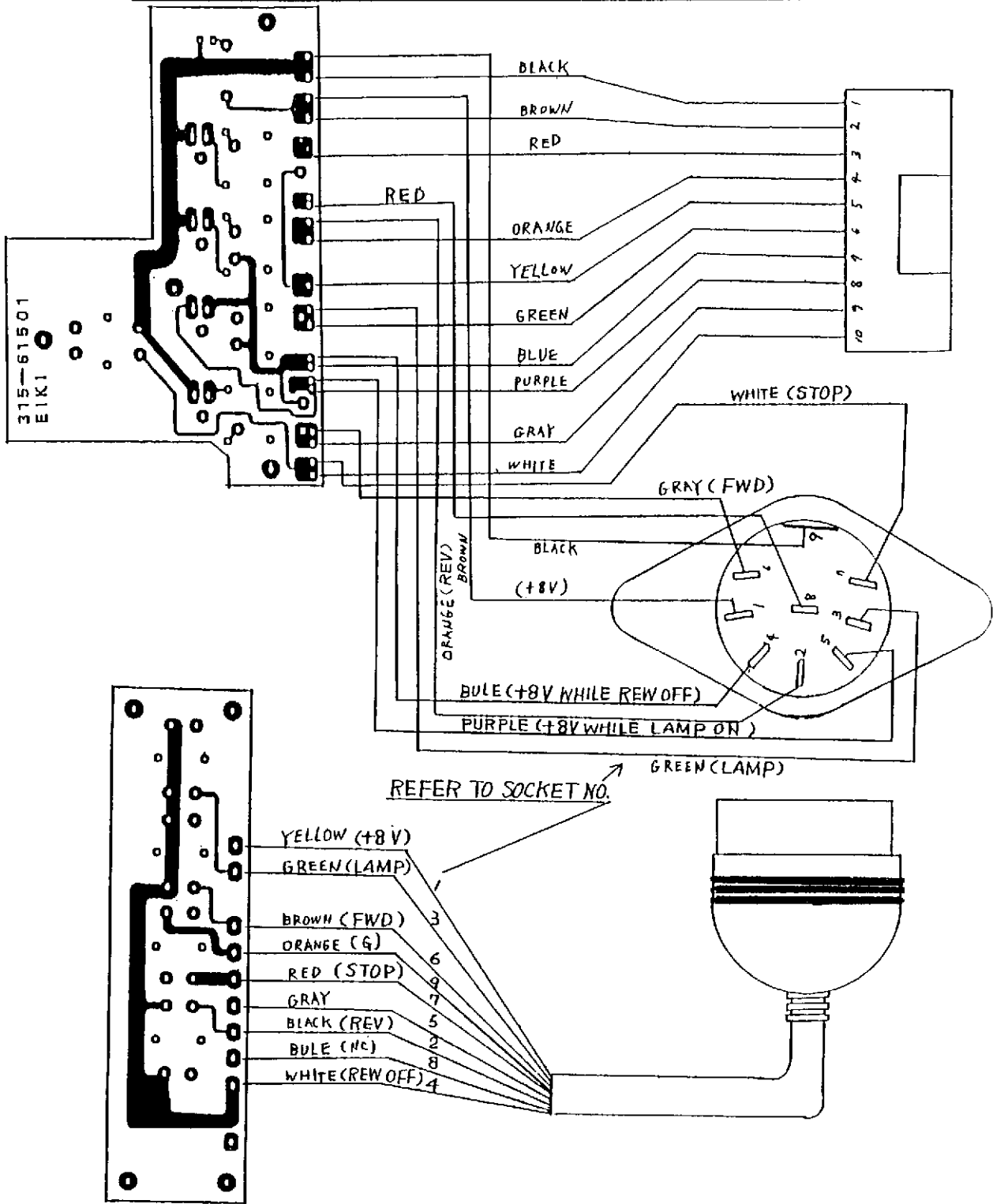

Fig. #100

|         |     |           |    |  |
|---------|-----|-----------|----|--|
| 処 理 加 工 |     | 図 面 訂 正 欄 |    |  |
| 符号      | 年月日 | 訂 正 要 領   | 担当 |  |
|         | ..  |           |    |  |
|         | ..  |           |    |  |



|          |             |       |   |         |     |           |                                   |
|----------|-------------|-------|---|---------|-----|-----------|-----------------------------------|
| 映機工業株式会社 |             |       |   | 承認      | 設計  | 製 國       | 品 名                               |
| 作 圖      | S.67年 7月 3日 | 尺 度   | / |         |     | 西 井       | PUSH BUTTON SW<br>CIRCUIT DIAGRAM |
| 材 質      | 台 数         | 單 重 量 | g | 製 品 記 号 | ENT |           |                                   |
|          |             |       |   |         | 部 番 | 315-60261 |                                   |